

# Manual on norms and standards for environment clearance of large construction projects

---

**Ministry of Environment and Forests,  
Government of India**

# Manual on norms and standards for environment clearance of large construction projects

---

**Ministry of Environment and Forests,  
Government of India**

---

**Suggested format for citation**

Manual on norms and standards for environment clearance of  
large construction projects  
New Delhi.

## PREFACE

“.....Presently, we are generating one trillion units of power for a billion population with certain economic strengths. And also we are using nearly 800 billion cubic meters (BCM) water both ground and surface. Our aim should be to conserve at least 10 to 15% of energy i.e. 100 billion units and 10% of water namely 80 BCM which will have a large impact on our economy. A good part of the nation’s energy is consumed by the construction industry and the household. By saving energy through Green buildings, we will make the air much purer to breathe. Green is safer, economically attractive and above all healthy. I would suggest that this should be the basis ..... to deliberate and prepare a decadal plan for the nation for implementation.”

(Excerpts from the speech on 15.9.05 at the Green Building Congress in New Delhi by  
Dr A P J Abdul Kalaam, President of India)

# Contents

	Page No.
Introduction	11
Background	11
A. Broad framework of notification	12
Application for Prior Environmental Clearance (EC)	13
Stages in the Prior Environmental Clearance (EC) Process for New Projects: -	13
Grant or Rejection of Prior Environmental Clearance (EC):	15
About the manual:	16
CHAPTER 1 Sustainable site planning	19
1.0 Introduction	19
1.1 Scope of work	19
1.2 Site selection	20
1.2.1 Concerns	20
1.2.2 Guidelines/Recommendations for Site Selection	21
1.3 Site analysis	29
1.3.1 Concerns	29
1.3.2 Recommendations and guidelines	32
1.4 Mitigation options for controlling air environment	51
1.4.1 Mitigation measures for wind erosion	51
1.4.2 Mitigation measures to control air pollution by plants	52
1.4.3 Mitigation measures for dust control	54
1.5 Water conservation	56
1.6 Health and well being of construction workers	57
1.7 Conclusive remarks	58
Reference	58
CHAPTER 2 Water management	59
2.0 Introduction	59
2.1 Issues of concern	59
2.2 Scope of the section	60
2.3 Mitigation technology options	60
2.3.1 Water conservation within buildings	60
2.3.2 Water quality	64
2.3.3 Water use reduction	65
2.3.4 Water conservation in landscape	66
2.3.5 Water quality standards for irrigation	68
2.4 Water conservation in process (air-conditioning)	69
2.4.1 Estimation of water demand	69
2.4.2 Mitigation options	69
2.4.3 Water quality standards for air- conditioning	70
2.5 Water use during construction	70
2.5.1 Parameters for water quality	70
2.5.2 Measures for reducing water demand during construction	71
2.6 Waste water generation	71
2.6.1 Introduction	71
2.6.2 Issues of concern	71

2.6.3 Estimation of waste water generated	71
2.6.4 Mitigation options	72
2.6.3 Standards for disposal of waste water	78
2.7 Construction wastewater management	79
2.8 Sanitation facilities for construction workers	80
2.9 Rain water harvesting	80
2.9.1 Introduction	80
2.9.2 Issues of concern	80
2.9.3 Measures to be taken	81
Annexure 2.1 Drought Resistant Plants	92
Annexure 2.2 : Native species for different agro-climatic zones	94
Central Highlands	94
Deccan Plateau	95
Eastern Plains	97
Eastern Plateau	99
Northern Region and North Eastern Hills	101
Western Region	103
Annexure 2.3 : Rain water run-off for different roof top areas	105
Annexure 2.4 : Details of filtration systems	106
Chapter 3 Managing transport including noise and air	109
3.0 Introduction	109
3.1 Scope	109
3.2 Pre construction (Site Planning) Guidelines	110
3.2.1 Concerns	110
3.2.2 Mitigation Options	110
3.3 Guidelines for reduction of pollution during construction and demolition activities	118
3.3.1 Concerns	118
3.3.2 Mitigation Options	120
Annexure 3.1 Area requirements for parking in different types of cities	124
Reference	125
CHAPTER 4 Building materials and technologies	127
4.0 Introduction	127
4.1 Scope	127
4.2 Issues and concerns	127
4.2.1 High consumption of resources	127
4.2.2 High Transportation Cost	128
4.2.3 Inefficient technologies and High consumption of materials	128
4.2.4 High life cycle cost of materials	128
4.2.5 Constituents of concern	129
4.3 Mitigation options	130
4.3.1 Envelope	131
4.3.2 Options for Superstructure	145
4.3.3 Alternatives for Finishes	147
4.3.4 Alternatives for roads and open spaces	147
Reference :	148
CHAPTER 5 Solid waste management	149
5.0 Introduction	149
5.1 Scope	150
5.2 Concerns	150
5.3 Mitigation options	152
5.3.1 Good practices in construction management	152

5.4 Construction and demolition Waste management	154
5.4.1 Waste recycling Plan	154
5.4.2 Handling	154
5.4.3 Demolition	154
5.4.4 Waste Segregation	155
5.4.5 Storage	155
5.4.6 Access to and from bin storage areas	155
5.5 Guidelines for municipal waste management	155
5.5.1 Collection	156
5.5.2 Storage	159
5.5.3 Bin area design and layout	159
5.5.4 Resource recovery or recycling	161
5.6 Hazardous Waste Management	164
5.6.1 Collection and storage of hazardous wastes during Pre construction and Post construction	166
5.6.2 Treatment	166
5.7 E-waste management	166
5.7.1 Collection and storage	167
5.7.2 Processing of e-waste	167
Reference	167
CHAPTER 6 Energy conservation	169
6.1 Introduction	169
6.1.2 Scope	169
6.1.3 Issues of concern	170
6.1.4 Recommendations and guidelines for solar passive architecture	170
6.2 Prescriptive requirements	185
6.2.1 Roofs	185
6.2.2 Opaque walls	185
6.2.3 Vertical fenestration	186
6.2.4 Skylights	188
6.3 Building envelope trade-off option	188
6.4 Lighting	191
6.4.1 Design for specified illumination level as recommended by the National building code 2005	192
6.4.2 Interior lighting power	203
6.4.3 Exterior lighting power	207
6.4.4 Lighting controls	210
6.5 Daylight integration in buildings	213
6.6 Solar Photovoltaic Systems (SPV)	216
6.7 Heating, ventilation and air conditioning	216
6.7.1 Heat load estimation	216
6.7.2 Green Refrigerant	222
6.7.3 Minimum equipment efficiencies	222
6.7.4 Controls	224
6.7.5 Piping & ductwork	225
6.7.6 Variable flow hydronic systems	226
6.8 Electrical system	226
6.8.1 Transformers	226
6.8.2 Energy Efficient Motors	227
6.8.3 Power Factor Correction	228
6.8.4 Diesel generator Captive Power Plants	228
6.8.5 Check-Metering and Monitoring	228
6.8.6 Power Distribution Systems	229
Reference	229

Annexure I	Mandatory and expected criteria	231
	Mandatory criteria	231
	Sustainable Site Planning	231
	Water Demand Management	232
	Managing Transport, Noise and Air	233
	Waste Management	233
	Energy conservation	234
	Expected Criteria	236
	Scoring Weightage :	<b>Error! Bookmark not defined.</b>
Annexure II	FORM-1 A (only for construction projects listed under item 8 of the Schedule)	239
	Check List Of Environmental Impacts	239
	1. Land Environment	239
	2. Water Environment	240
	3. Vegetation	241
	4. Fauna	241
	5. Air Environment	241
	6. Aesthetics	242
	7. Socio-Economic Aspects	242
	8. Building Materials	242
	9. Energy Conservation	243
	10. Environment Management Plan	244
Annexure III	Indicative list of submittals as required to fill in form I A	245
	Annexure for submittals	253
	6.8.7 Building Energy Performance Index (BEPI)	253
	6.8.8 BEPI calculation method	253



## List of tables

Table 1.1: National ambient air quality standards for different building typologies as per CPCB .....	24
Table 1.2 Water quality standard for drinking water.....	25
Table 1.3: Ambient Standards for noise.....	26
Table 1.4: Rating chart for soil test values of primary nutrients .....	34
Table 1.5 Runoff coefficients of various surfaces .....	35
Table 1.6: NBC Standards for imperviousness.....	36
Table 1.7: Degree of maintenance required (for vegetation).....	50
Table 1.8 Factors influencing degree and kind of wind erosion .....	51
Table 2.1: Water requirements for different types of buildings.....	61
Table 2.2 Standards for drinking water.....	64
Table 2.3 Water quality standards for freshwater classification .....	64
Table 2.4 : Estimation of water use reduction .....	65
Table 2.5 Efficiency of irrigation equipment.....	67
Table 2.6: Estimate of savings in water .....	68
Table 2.7: Standards for irrigation.....	68
Table 2.8 Permissible limits for effluent disposal.....	78
Table 2.9 Runoff coefficients for different surfaces .....	82
Table 2.10 Hydraulic conductivities of soil .....	85
Table 2.11 Infiltration Rate of Different Texture (CM\Hour) .....	86
Table 2.12 Specific Yield of Different Formation .....	86
Table 2.13 Typical Porosities of soil .....	86
Table 3.1: Design considerations for Roads of different Hierarchy .....	112
Table 3.2 Space standards for footpath .....	112
Table 3.3: Space standards for bicycle tracks .....	113
Table 3.4 Area requirements for different types of parking.....	116
Table 3.5 Space standards for Car Parking .....	117
Table 3.6 Typical noise levels of some point sources .....	119
Table 3.7: Stack Height standards for D.G. Sets .....	123
Table 3.8: Emission limits for Noise.....	123
Table 4.1: Embodied energy Content of the materials .....	128
Table 5.1: Wastes produced by building construction industry.....	150
Table 5.2: Garbage Management in Some Cities .....	151
Table 5.3 : Quantities of municipal and solid wastes, generation in metro cities .....	157
Table 5.4 Composition of Municipal Solid Waste.....	158
Table 5.5 : Space required for waste storage.....	158
Table 6.1 Climate zone and their characteristics .....	170
Table 6.2 Roof assembly U-factor and insulation R-value requirements* .....	185
Table 6.3: Opaque wall assembly U-factor and insulation R-value requirements.....	186
Table 6.4: Vertical fenestration U-factor and SHGC requirements .....	186
Table 6.5: SHGC “M” factor adjustments for overhangs and fins .....	187
Table 6.6: Minimum VT requirements.....	188
Table 6.7: Skylight U-factor and SHGC Requirements .....	188
Table 6.8: Envelope performance factor coefficients – Composite climate .....	189
Table 6.9: Envelope performance factor coefficients – Hot dry climate.....	189
Table 6.10: Envelope Performance Factor Coefficients – Hot Humid Climate.....	190
Table 6.11: Envelope Performance Factor Coefficients – Moderate Climate .....	190
Table 6.12: Envelope Performance Factor Coefficients – Cold Climate.....	190
Table 6.13: Recommended Values of illuminance for some common activities as recommended by National Building Code 2005 .....	193
Table 6.14 Interior lighting power – building area method.....	204
Table 6.15 Interior lighting power – space function method.....	205

Table 6.16 Exterior Building Lighting Power.....	207
Table no. 6.17 Luminous efficacy of lamps.....	208
Table 6.18: Inside design conditions for some applications .....	216
Table 6.19: Summary for outdoor conditions Source .....	218
Table 6.20: Minimum air requirements for ventilation of all common areas and commercial facilities.....	220
Table 6.21: Unitary air conditioning equipment.....	222
Table 6.22: Chillers .....	222
Table 6.23: Heating pumps heating mode .....	223
Table 6.24: Furnaces.....	223
Table 6.25: Boilers .....	224
Table 6.26: Ductwork Insulation .....	225
Table 6.27: Maximum Allowable Losses of 11, 22 kV Transformers .....	226
Table 6.28 : Minimum acceptable motor efficiencies .....	227
Table 6.29 Recommended specific fuel consumption of DG sets.....	228
Table 6.30: Recommended BEPI for different types of buildings.....	253
Table 6.31: Estimation of energy consumption in lighting system.....	253
Table 6.32 : Estimation of energy consumption in air conditioning system .....	255
Table 6.33 : Estimation of building energy performance index .....	256

## Background

With an economic growth rate of 8.9%, which is the second fastest in the world, India is fast seen emerging as a major global business giant. With 35 cities with populations in excess of 1 million, and more cities joining the list, investments in urban infrastructure are projected to be higher than ever before. This of course is besides the investments already coming into the economy via 'foreign direct investments' into urban real estate development. This is one sector of the Indian economy that has activities, which are directly or indirectly linked to every other economic sector. The gross built-up area added to commercial and residential spaces was about 40.8 million square meters in 2004-05; the trends show a sustained growth of 10% over the coming years.

Construction activities in India have been pursued without giving much attention on environmental issues. This has resulted in pressure on its finite natural resources, besides creating impacts on human health and well-being. Unplanned and unsustainable urban development has led to severe environmental pressures. The green cover, ground water resources have been forced to give way to the rapidly developing urban centres. Modern buildings built in our cities have high levels of energy consumption because of requirements of air-conditioning and lighting.

The objectives of the Notification dated 15th September 2006 is to set procedures of environmental clearance before establishment of a project of identified nature and size. The suitability of site for a proposed development is one of primary concerns in according environmental clearance to a project. This will include detailed examination of the nature of receptors and magnitude of anticipated impact on account of the proposed project.

Large projects tend to have associated and consequential impacts. Innovative approaches should be adopted to conserve resources, in particular, energy and water. Backward linkages of the proposed project, such as the source and manner of procurement of materials and forward linkages, such as kind and manner of disposal of debris, should be duly considered along with the proposed project.

Besides environment, the aspects related to security, health and equity should be duly considered. Government will facilitate, not merely regulate, development related to all projects covered by this notification. The guidelines outlined

here have been prepared to help the proponents in the preparation of documents to be submitted for environmental clearance. The guidelines outline the following:

- A. Revised requirement of environmental clearance for construction projects.
- B. Impacts and mitigation Measures for Site, Planning & Development
- C. Impacts and mitigation for Water Management
- D. Impacts and Mitigation Measures for transport Management and Air Pollution Control
- E. Impacts from Building materials and Constructions including Solid Waste Management
- F. Energy conservation Measures including Bio-climatic Design
- G. Set of mandatory and expected criteria to be followed by the developer
- H. Submittals required to address questions in Form1 and 1A of the notification

#### A. Broad framework of notification

The Government of India enacted Environment Protection Act, in 1986. The process of Environmental Impact Assessment was made mandatory in 1994 under the provisions of the Act. From time to time amendments have been made to the EIA Notifications. Extending the provisions of the Act to cover additional activities, the notification was amended on 7.7.04 to include large construction projects including new townships and industrial estates. The notification was further amended on 14.09.06 and the environmental clearance for large construction projects was redefined and modified. The environmental clearance for large construction projects can be summarised as follows:

- All Building /Construction projects/Area Development projects and Townships with threshold limits as given in table below shall need environmental clearance.

Project or Activity		Category with threshold limit		Conditions if any
		A	B	
(a)	(2)	(3)	(4)	(5)
(1)				
8		Building /Construction projects/Area Development projects and Townships		
8(a)	Building and Construction projects	≥20000 sq.mtrs and <1,50,000 sq.mtrs. of built-up area#		#(built up area for covered construction; in the case of facilities open to the sky, it will be the activity area)
8(b)	Townships and Area Development projects.	Covering an area ≥ 50 ha and or built up area ≥1,50,000 sq .mtrs		**All projects under Item 8(b) shall be appraised as Category B1
		++		

The environmental clearance procedure for project under above category can be summarised as below:

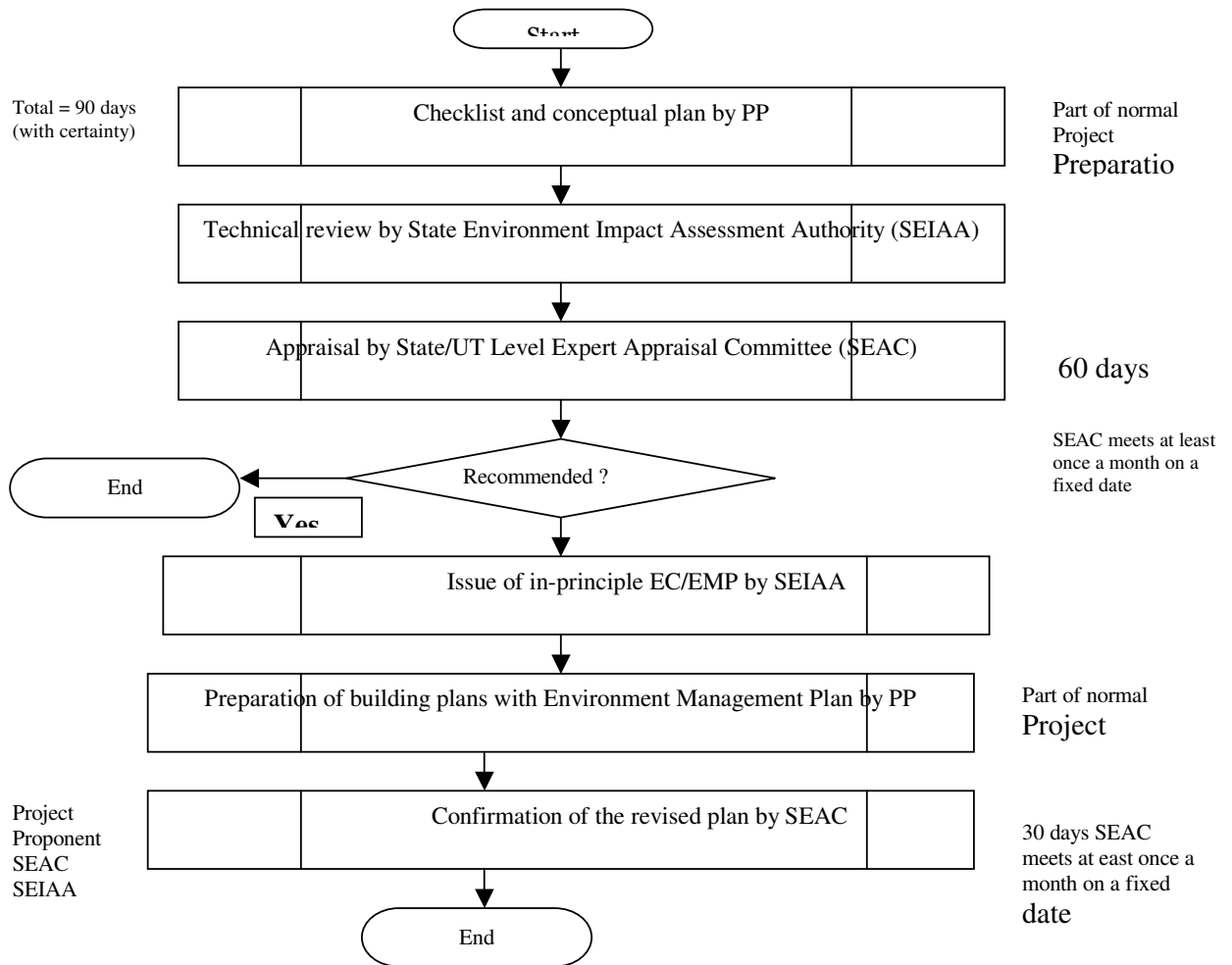

#### Application for Prior Environmental Clearance (EC)

An application seeking prior environmental clearance in all cases shall be made in the prescribed Form 1 annexed herewith and Supplementary Form 1A as given in Appendix II, after the identification of prospective site(s) for the project and/or activities to which the application relates, before commencing any construction activity, or preparation of land, at the site by the applicant. The applicant shall furnish, along with the application, in addition to Form 1 and the Supplementary Form 1A, a copy of the conceptual plan.

#### Stages in the Prior Environmental Clearance (EC) Process for New Projects: -

The environmental clearance process for new projects will comprise of a maximum of 2 stages. These stages in sequential order are

- Screening
- Appraisal

*Screening:*

This stage will entail the scrutiny of an application seeking prior environmental clearance made in Form 1 and Form 1A by the concerned State level Expert Appraisal Committee (SEAC) for determining whether or not the project or activity requires further environmental studies for preparation of an Environmental Impact Assessment (EIA) for its appraisal prior to the grant of environmental clearance depending up on the nature and location specificity of the project. The projects requiring an Environmental Impact Assessment report shall be termed Category 'B1' and remaining projects shall be termed Category 'B2' and will not require an Environment Impact Assessment report. For categorization of projects into B1 or B2 except item 8 (b), the Ministry of Environment and Forests shall issue appropriate guidelines from time to time.

All projects and activities listed as Category 'B' in Item 8 of the Schedule (Construction/Township/Commercial Complexes /Housing) shall not require scoping and will be appraised on the basis of Form 1/ Form 1A and the conceptual plan.

*Applications for prior environmental clearance may be rejected by the regulatory authority concerned on the recommendation of the EAC or SEAC concerned at this stage itself. In case of such rejection, the decision together with reasons for the same shall be communicated to the applicant in writing within sixty days of the receipt of the application.*

*Appraisal:*

1. Appraisal means the detailed scrutiny by the Expert Appraisal Committee or State Level Expert Appraisal Committee of the application and other documents like the Final EIA report, submitted by the applicant to the regulatory authority concerned for grant of environmental clearance. This appraisal shall be made by Expert Appraisal Committee or State Level Expert Appraisal Committee concerned in a transparent manner in a proceeding to which the applicant shall be invited for furnishing necessary clarifications in person or through an authorized representative. On conclusion of this proceeding, the Expert Appraisal Committee or State Level Expert Appraisal Committee concerned shall make categorical recommendations to the regulatory authority concerned either for grant of prior environmental clearance on stipulated terms and conditions, or rejection of the application for prior environmental clearance, together with reasons for the same.
2. The appraisal of all projects or activities which are not required to undergo public consultation, or submit an Environment Impact Assessment report, shall be carried out

on the basis of the prescribed application Form 1 and Form 1A as applicable, any other relevant validated information available and the site visit wherever the same is considered as necessary by the Expert Appraisal Committee or State Level Expert Appraisal Committee concerned.

3. The appraisal of an application shall be completed by the Expert Appraisal Committee or State Level Expert Appraisal Committee concerned within sixty days of the receipt of the final Environment Impact Assessment report and other documents or the receipt of Form 1 and Form 1A, where public consultation is not necessary and the recommendations of the Expert Appraisal Committee or State Level Expert Appraisal Committee shall be placed before the competent authority for a final decision within the next fifteen days .

#### Grant or Rejection of Prior Environmental Clearance (EC):

1. The regulatory authority shall consider the recommendations of the EAC or SEAC concerned and convey its decision to the applicant within forty five days of the receipt of the recommendations of the Expert Appraisal Committee or State Level Expert Appraisal Committee concerned within one hundred and five days of the receipt of the complete application with requisite documents, except as provided below 90 days?
2. The regulatory authority shall normally accept the recommendations of the Expert Appraisal Committee or State Level Expert Appraisal Committee concerned. In cases where it disagrees with the recommendations of the Expert Appraisal Committee or State Level Expert Appraisal Committee concerned, the regulatory authority shall request reconsideration by the Expert Appraisal Committee or State Level Expert Appraisal Committee concerned within forty five days of the receipt of the recommendations of the Expert Appraisal Committee or State Level Expert Appraisal Committee concerned while stating the reasons for the disagreement. An intimation of this decision shall be simultaneously conveyed to the applicant. The Expert Appraisal Committee or State Level Expert Appraisal Committee concerned, in turn, shall consider the observations of the regulatory authority and furnish its views on the same within a further period of sixty days. The decision of the regulatory authority after considering the views of the Expert Appraisal Committee or State Level Expert Appraisal Committee concerned shall be final and conveyed to the applicant by the regulatory authority concerned within the next thirty days.
3. In the event that the decision of the regulatory authority is not communicated to the applicant within the period specified in sub-paragraphs (1) or (2) above, as applicable,

the applicant may proceed as if the environment clearance sought for has been granted or denied by the regulatory authority in terms of the final recommendations of the Expert Appraisal Committee or State Level Expert Appraisal Committee concerned.

4. On expiry of the period specified for decision by the regulatory authority under paragraph (1) and (2) above, as applicable, the decision of the regulatory authority, and the final recommendations of the Expert Appraisal Committee or State Level Expert Appraisal Committee concerned shall be public documents.
5. Clearances from other regulatory bodies or authorities shall not be required prior to receipt of applications for prior environmental clearance of projects or activities, or screening, or scoping, or appraisal, or decision by the regulatory authority concerned, unless any of these is sequentially dependent on such clearance either due to a requirement of law, or for necessary technical reasons.
6. Deliberate concealment and/or submission of false or misleading information or data which is material to screening or scoping or appraisal or decision on the application shall make the application liable for rejection, and cancellation of prior environmental clearance granted on that basis. Rejection of an application or cancellation of a prior environmental clearance already granted, on such ground, shall be decided by the regulatory authority, after giving a personal hearing to the applicant, and following the principles of natural justice.

For other relevant clauses as below:

Validity of Environmental Clearance (EC):

Post Environmental Clearance Monitoring:

Transferability of Environmental Clearance (EC),

please refer to the website of The Ministry of Environment and Forests, Government of India

#### About the manual:

The manual has been developed to assist developers and project proponents measure and quantify environmental impacts of proposed construction, and derive mitigation options to minimise impacts. The manual also shall enable evaluation of construction projects by the expert appraisal committee. The proponent may use mitigation options, other than the ones described in the manual, to mitigate environmental impacts of respective projects.

The manual provides a range of environmental issues that need to be considered in assessing the environmental impacts of construction projects and how to identify and assess the issues relevant to the particular project. The measures are suggestive



and intended to assist project specific environmental management practices.

List of submittals required to fulfil requirements of Form 1 and 1A have been appended. This manual also comprises of a list of mandatory and expected criteria that needs to be adopted in a project for getting necessary clearance from regulatory authority.



---

# CHAPTER 1 Sustainable site planning

## 1.0 Introduction

Site planning is a vital component of any type of building activity and is the first step. With growing urban development and environmental degradation it has become imperative to determine landscape design parameters, and also provide rules, regulations, controls and procedures for the protection, preservation and modification of surrounding environment. In most of the cases the site is selected by the developer before commencement of design phase. However, ideally the design team should be involved in site selection and should assess the appropriateness of the site relative to the proposed development. Analysis and assessment of the site characteristics in terms of its capacity to provide natural resources inside the building such as light, air and water without damaging the natural environment should be carried out during site selection and analysis process. The process has been divided into two parts: site selection and site analysis. The concerns related to all natural resources during site planning are covered in the site analysis section. The aim is to integrate an architecturally sustainable design with the natural environment with least damage to the nature and at best improving it by restoring its balance.

## 1.1 Scope of work

Sustainable site planning section of the manual covers two aspects: first site selection process, which brings it upfront all elements that would affect future development of the project. The second part is site analysis, which brings it upfront all those elements and natural resources that would get affected by the project.

The elements that get affected on site due to project development are: - Soil conditions if not preserved, hydrology of the site, topography and characteristics of land due to hard paving and built up spaces on the site, existing vegetation, solar access, and wind patterns. Mitigation options are provided in the site analysis section that would help reduce the negative impact of large construction projects on natural resources.

Site analysis section of this manual focuses on the need to consider management of resources during the design and development of the project at macro level with respect to the overall site. Impact on the resources, guidelines to mitigate negative impact, best practices, mandatory clauses, dos and don'ts for management of following resources are covered:

1. Soil

2. Land use
3. Vegetation
4. Air
5. Water
6. Waste
7. Health and well-being of construction workers

## 1.2 Site selection

The process of site selection for sustainable development involves identifying and weighing the appropriateness of the site with respect to sustainable building design criteria. This step is the first step and needs to be done long before the project's design phase commences. Appropriate site selection procedure reduces the negative impacts and requirement for mitigation measures for large construction projects. Site selection and analysis should be carried out to create living spaces for people in harmony with the local environment. The development of a project should not cause damage to the natural surrounding of the site but in fact should try to improve it by restoring its balance. Thus site selection should be carried out in light of a holistic perspective of land use, development intensity, social well-being and preservation of the environment. The selection should be based upon several feasibility and impact studies related to sustainability such as existing wind pattern, solar access, soil, air, water conditions, noise pollution, and bio diversity.

### 1.2.1 Concerns

#### *1.2.1.1 Land use*

The first feature, which should influence development of a new project, is the existing land use pattern of the neighbourhood of the project: whether the proposed development conforms to the development for that area. Recommendations for site selection are provided in this chapter.

#### *1.2.1.2 Location of site with respect to existing eco-system on site*

Development of new construction projects should not have a negative impact on the existing bio diversity and ecosystem of the site. Development of the project on the located site should not disturb sites with heritage and cultural values such as protected monuments. Constructed projects on selected sites should not disturb aesthetics and scenic beauty of a location.

#### *1.2.1.3 Ambient environment quality in the region*

Levels of air, noise and water pollution should be surveyed and considered carefully before implementing the building design. For example: High level of air, noise and water pollution and location near pollution sources such as heavy traffic roadways

should be considered carefully to implement residential building.

#### *1.2.1.4 Availability of infrastructure*

The fourth feature which should influence site selection for the development of a project are the infrastructure and utilities available, expected water and power requirement by the proposed new buildings and feasibility study of how much is available and what is the source of supply for power and water. The developer should submit the list of items asked in Form 1 and 1A as a proof to confirm the availability of infrastructure.

#### **1.2.2 Guidelines/Recommendations for Site Selection**

Site selection process includes analysis of several site factors. These are land-use, eco-system and diversity history and heritage, urban context and the environmental considerations. This part of chapter suggests guidelines for site selection including all these features.

##### *1.2.2.1 Land use*

The first concern while selecting the site should be suitability of the site. This should be analysed with respect to the surrounding existing development, natural environment and urban environment to define whether the site should be built or not and secondly to judge whether the proposed development is best suited on the considered site. Proposed land use must conform to the approved Master Plan/Development plan of the area. If there is no approved Plan, consent from appropriate authority should be taken and should be submitted for Environment clearance. If the area is outside municipal limits /outside planning area, full justification for the proposed development should be provided.

##### *1.2.2.2. Ecosystems and diversity*

Sites for new developments should be carefully assessed in context of the wider environment particularly in relation to the habitats dwelling on site or on adjacent sites. There may exist on the site some rare or endangered species of plants and animals, such sites are considered unsuitable for development. The site(s) selection can be an effective approach in minimising the requirement of mitigation measures. Project siting restrictions depend on the sensitivity of the site and its surrounding environment and the following considerations should be made while selecting a site.

##### **1.2.2.3 Analysis of cultural/historical considerations**

1. Review the traditional or vernacular architecture of the region. : The regional architectural style may be revealed through the use of vernacular architecture to

- form a design that is responsive to the local cultural characteristics, thus enhancing community values.
2. Restore historical or cultural resources on-site: Historical features on-site can be integrated by either modifying or incorporating parts of the existing structure into the proposed design, thus adding to the cultural fabric of the area provided that these structures are not legally protected.
  3. Use of historical, energy efficient building techniques: Historical, energy efficient building techniques that have been involved and sustained in response to local climatic or cultural characteristics can be used or modified to suite the proposed suitable design.

#### *1.2.2.4 Analysis of urban context considerations*

1. Analyse the city form: The delineation of the city form due to layout of roads, open spaces, or architectural forms should be analysed. For example, a building may be visually unifying element, providing connections and continuity with adjacent buildings. Sites at the end of important vistas or adjacent to major city squares should be reserved for important public buildings.
2. Review the potential of views: Important city views of plazas, squares, monuments, and natural features (such as parks and water fronts) should be considered. It is important to design the proposed building in a manner that will enhance and preserve such views for the public.

#### *1.2.2.5 Urban availability of water and other critical infrastructures like electricity, roads with adequate width and capacity.*

1. The design team should gauge whether the site takes maximum advantage of natural resources, such as solar energy, natural vegetation, and geographical features, and should also analyse the proximity or remoteness of the site from existing transportation corridors, and its ability to match the needs of the building owner, users, and their occupancy patterns.
2. Resource and needs' assessment of the project should be done at this pre-design stage. Issues which need to be identified at pre design and site selection stage are: connectivity to infrastructure and public transport networks, power requirement and power source, water requirement and water source, waste management on the site.
3. Urban infrastructure and facilities, public transport, infrastructure for power, water supply to meet the estimated requirement, sewage system network should be available nearby or should be made available with minimum environment impact. For example the

residential areas should be well connected to the utilities like school, market place, sports and recreational facilities to meet the basic needs of a residential society. The team should also see whether the waste output could be dealt with acceptable environmental costs and whether development impacts can be minimised on site. It is desirable to integrate the existing utility and infrastructure, and identify whether additional infrastructure needs to be planned for the proposed project. Whatever, the case may be, additional cost or the associated disruption to the environmental or surrounding system may sometimes question the project's integrity.

4. Take into consideration the impact of proposed future development on the infrastructure.
5. Sharing of existing transportation or parking facilities may minimise the budget for infrastructure.

#### *1.2.2.6 Onsite management of waste*

1. Land acquired should be minimum but sufficient to provide for a green belt wherein the treated wastewater, if possible/ suitable, could be utilised from wastewater treatment systems.
2. Space onsite for solid waste: Enough space may be provided for storing solid wastes. The space and the waste can be made available for possible reuse in future.
3. Reuse negative urban spaces or industrial site: This should be done when existing urban amenities and infrastructure can be utilized, thus reducing the pressure on undeveloped land. If possible and justified in terms of sustainable design goals, select a site that offers a possibility of urban redevelopment, (or where development is constrained due to environmental pollution or increasing urban pressure), or which uses existing urban infrastructure confirming the desired density goals. This would help reduce the perennial pressures on the undeveloped land to some extent.
4. Conformance to existing landscape: Layout and form of the project must conform to the landscape of the area without unduly affecting the scenic features of that place.

#### *1.2.2.7 Environmental consideration*

In addition to the siting criteria listed above, the proposed project location should meet the standards prescribed by the Central Pollution Control Board (CPCB) and IS standards for the following environment parameters:

- Ambient air, water and noise quality standards
- Natural disaster prone areas
- Ecologically sensitive areas

For example, high level of air, noise and water pollution and location near pollution sources such as heavy traffic roadways should be considered carefully to implement residential building.

1. Ambient air: Assess the existing air quality of the site to determine if it falls under the permissible average levels as prescribed by Central Pollution Control Board (CPCB). It should also be ensured that the development would not further deteriorate the air quality. Air quality monitoring involves estimation of concentration levels of suspended particulate matter (SPM), Respirable suspended particulate matter (RSPM), Sulphur dioxide (SO<sub>2</sub>), oxides of Nitrogen (NO<sub>x</sub>) and Carbon monoxide (CO) in the study area.

The methodology and permissible levels are given below. Testing should be carried out by standard and certified national laboratories.

Method of analysis:

The air quality parameters are analysed as per IS-5182 – Method of measurement of pollution

SPM: Gravimetric Analysis (IS-5182, Part-II)

SO<sub>2</sub>: Modified west & gaeke method (IS-5182, Part IV)

NO<sub>x</sub>: Jacobs & Hochheiser Method (IS-5182, Part X)

CO: Indicator Tube method (IS-5182, Part-I)

The gaseous pollutant concentrations are compared with National Ambient Air quality standards prescribed by CPCB for i) Industrial area ii) Residential, rural and other areas, iii) sensitive areas

Table 1.1: National ambient air quality standards for different building typologies as per CPCB

Pollutant	Sulphur di Oxide SO <sub>2</sub>		Oxides of Nitrogen (NO <sub>2</sub> )		Suspended Particle Material SPM	
	Annual	24 hours	Annual	24 hours	Annual	24 hours
Time	Annual	24 hours	Annual	24 hours	Annual	24 hours
Weighted Average	Average	Average	Average	Average	Average	Average
Industrial Area	80 ug/m <sup>3</sup>	120 ug/m <sup>3</sup>	80 ug/m <sup>3</sup>	120 ug/m <sup>3</sup>	360 ug/m <sup>3</sup>	500 ug/m <sup>3</sup>
Residential Rural and other area	60 ug/m <sup>3</sup>	80 ug/m <sup>3</sup>	60 ug/m <sup>3</sup>	80 ug/m <sup>3</sup>	140 ug/m <sup>3</sup>	200 ug/m <sup>3</sup>
Sensitive Area	15 ug/m <sup>3</sup>	30 ug/m <sup>3</sup>	15 ug/m <sup>3</sup>	30 ug/m <sup>3</sup>	70 ug/m <sup>3</sup>	100 ug/m <sup>3</sup>

Source: CPCB

- Annual Arithmetic Mean of minimum 104 measurements in a year taken twice a week 24-hourly at uniform interval.



- 24-hourly/8-hourly values should be met 98% of the time in a year. However 2% of the time, it may exceed but not two consecutive days.

Notes:

1. The level of air quality necessary with an adequate margin of safety, to protect the public health, vegetation and property.
2. Whenever and wherever two consecutive values exceeds the limit specified above for the respective category, it would be considered adequate reason to institute regular/continuous monitoring and further investigations.

(Source: [http://envfor.nic.in/cpcb/aaq/aaq\\_std.html](http://envfor.nic.in/cpcb/aaq/aaq_std.html))

*Mitigation measures to control air pollution:*

Air pollution may be caused by areas or point sources such as cities, industrial areas, factories or by linear sources such as highways. Vegetation buffers can minimize the build-up of pollution levels in urban areas by acting as pollution sinks. For details please refer section 1.3.2.4.

1. Water quality: Ensure water from all sources such as ground water, municipal water meets the water quality norms as prescribed in the Indian Standards for drinking, IS: 10500-1991 and CPWD specifications to meet the specifications prescribed for construction water.

Table 1.2 Water quality standard for drinking water

Parameter	Drinking water (IS 10500: 1991)
Total hardness (as CaCO <sub>3</sub> ) (mg/litre)	300
Total dissolved solids (mg/litre)	500
Chlorides as chlorine (mg/litre)	250
Colour (hazen)	5
Turbidity (NTU)	5
Alkalinity (mg/l)	200
Calcium (as Ca), mg/l	75
Boron (mg/litre)	1
Sulphates (as SO <sub>4</sub> ) (mg/litre)	200
Nitrates (as NO <sub>3</sub> ) (mg/litre)	45
Conductivity at 25o C (us/cm)	-
pH	6.5 – 8.5

Parameter	Drinking water (IS 10500: 1991)
Anionic detergents as MBAS (mg/l)	0.2
Arsenic (mg/litre)	0.05
Iron (mg/litre)	0.3
Fluorides (mg/litre)	1
Lead (mg/litre)	0.05
Copper (mg/litre)	0.05
Zinc (mg/litre)	5
Phenolic compounds (as C6H5OH) (mg/l)	0.001
Cyanide (mg/l)	0.05
Chromium (mg/l)	0.05

Source: (IS 10500: 1991)

*Mitigation measures to obtain the prescribed water quality:*

Please refer Water Section 2.3.1 to consider options and measures which should be adopted on site to meet the standards of water required for construction during construction stage and to meet the drinking water standards, if the source of supply for drinking water does not comply to the prescribed standards.

1. Noise quality: Noise level survey should be carried out with respect to the proposed project in order to assess the background levels and to ensure that the outdoor noise levels conform to the standards prescribed by Central Pollution Control Board (CPCB) for industrial, commercial, residential and silence zones. The CPCB – Environmental Standards – Noise (ambient standards) are given below:

Table 1.3: Ambient Standards for noise

Area code	Area category	Limit in dB (A) Leq	
		Daytime	Night time
A	Industrial area	75	70
B	Commercial area	65	55
C	Residential area	55	45
D	Silence zone	50	40

Source: CPCB

Note 1: Daytime is reckoned in between 6 a.m. and 9 p.m.

Note 2: Night time is reckoned in between 9 p.m. and 6 a.m.

- Note 3: Silence zone is defined as areas up to 100 metres around such premises as hospitals, educational institutions, and courts. The silence zones are declared by a competent authority.
- Note 4: Mixed categories of areas should be declared as 'one of the four above mentioned categories by the competent authority and the corresponding standards shall apply.

The purpose of noise control is to ensure that people are not harmed or disturbed by noise. Whenever necessary, experts in the field may be consulted for complex situations. Some generic guidelines are given in this section as provided in National Building Code 2005. Noise is either generated by traffic (road, rail and underground railway) or it arises from zones and buildings within the built up area (industry, commerce, offices and public buildings). During site selection survey should be conducted to examine all possible causes of noise, nuisance and consider ways and measures to maintain the ambient noise levels as prescribed by CPCB. While planning care should be taken that the housing colonies are adequately setback from busy airports, state and national highways, factories, main railway lines and marshalling yards.

*Mitigation options to control noise pollution:*

It is important that no new development is carried out within areas where expected noise levels will cause mental and physical fatigue or permanent loss of hearing. In case development in such areas is essential, adequate sound insulation shall be provided for the building.

1. Control measures: There are two ways of applying controls or measures. The first is to plan so as to keep the noise at a distance. Under this aspect comes the separation of housing from traffic noise by interposing buffer zones, and the protection of schools and hospitals by green belts, public gardens, etc. The second is the principle of shading or screening. This consists of deliberately interposing a less vulnerable building to screen a more vulnerable one or by providing a solid barrier such as a wall between the source and the location to be protected.
2. Control of Aircraft noise: The problem caused by aircraft noise have become very acute, therefore a commonly used criterion is the noise exposure forecast (NEF). Aircraft noise can seriously affect living conditions no matter how much insulation has been applied. For this reason it is recommended that no residential development should be allowed beyond NEF 35 level. For very critical buildings such as buildings necessary for maintaining and supplementing the

airport services, and for commercial development, such as hotels, it is possible to provide sealed windows and to centrally air condition the entire building.

3. Control of noise from railway lines: Wherever possible no residential or public building zone should abut onto railway lines. The appropriate zones along side railway lines are industrial and commercial buildings other than office buildings.

4. Control of noise from road traffic: Road traffic can be more nuisance than rail traffic. Care should be taken that local housing roads do not provide short cuts for heavy traffic zones through residential areas. Trees with heavy foliage planted on both sides of carriage way help slightly muffle the noise provided; the foliage extends for a considerable distance of 30m or above.

Highway noise barriers are effective means of reducing traffic noise around residential areas. There are two types of barriers that can be built to protect sites; one which are built to solely for the purpose of reducing noise and two, which forms a part of the building complex (barrier blocks). Freestanding walls and artificial mounds are typical examples of the first type and multi-storied dwellings and garages are the most common of type two. Out of the two types, barrier blocks are more widely used because they are cheaper and also tend to form a more effective barrier because of their greater height and width.

5. Setting up the barriers: National Building Code 2005 suggests that design solutions such as barrier blocks should be used to reduce external LA10 noise levels to at least 60-70dB(A) at any point 1.0 m from any inward looking façade. Green belts and landscaping could act as an effective means to control noise pollution. In case of railway tracks, a minimum distance of 50m to 70m may be provided between the buildings and the tracks. Thick belts of planting greater than 30 meters are useful for cutting the noise levels from road traffic. Strong leafy trees may be planted to act as noise baffles. Shrubs and creepers may also be planted for additional protection between tree trunks; artificial mounds and banks shall be formed where practicable. As little hard paving and as much grass as possible may be used. The creation of green belt is particularly advisable on the perimeter of aerodromes, along railway lines and arterial roads, through or past built up areas and adjoining industrial zones.

#### *1.2.2.8 Natural disaster prone areas*

Examine historical data for past trends of natural hazards, such as earthquakes, floods, or landslides, so that proposed

development can be designed with the ability to withstand such eventualities. Other investigations may be carried out on relative mappings of natural winds, floods, or climatic data to ascertain the possibility of any other risks involved. If possible, new choices or other complementary structural techniques should be developed for the site.

### 1.3 Site analysis

After the first analysis of the site evaluation and site selection, the site should be analysed with respect to all the issues involved in its sustainable development. The natural functions of a plot of land (hydrology, geology and microclimate) could be seriously disrupted by the placement of buildings on it if site analysis for optimum placement and design of buildings is not carried out. Layout the site activities and building requirements after carrying out detailed site analysis so as to ensure sustainable site development is in tune with its topography, climate, ecological character and functional requirements of the building. The main objective is to allocate and define the use of various parts of the site in a manner that is most appropriate to specific building activities to be carried on the proposed site. The purpose of site analysis is also to determine the site characteristics so that proper drainage pattern and system, circulation pattern, landscape design and other site development features can be considered in relation to the existing site features and proposed building design parameters such as building form, solar orientation, shape, skin to volume ratio, materials etc.

The site analysis evaluates all the environmental determinants, which include (soil, air, water, solar access, noise), that could get affected due to development on the proposed site. All the concerns and mitigation options for the concerns at site level are covered in this section. Impact of development of the project on ecology and available resources on site, example impact of building shade on open spaces, existing wind patterns on the site, impact on soil erosion, existing vegetation, habitat protection, water and air pollution and waste handling should be assessed and mitigation options to reduce the negative impact on the resources as suggested in this document should be carried out.

#### 1.3.1 Concerns

##### *1.3.1.1 Building siting*

Geographical latitude and microclimatic factors such as wind loads and solar access: Improper planning and layout of buildings can affect the availability of natural resources to the occupants. For example, Large built volumes perpendicular to the wind divert the latter and tend to create a wind shadow of a length equal to 15 times the building's height (with wind

velocity halved down). Design of buildings could result in overshadowing existing buildings and sometimes also result in cutting down the availability of natural light in adjacent buildings. The way in which a building or group of buildings are sited in relation to other buildings, natural topography and landscape could have detrimental effects on its potentialities.

#### *1.3.1.2 Impact on soil due to land disturbance :*

Top soil conservation: Topsoil is rich in organic content and is essential to establish new vegetation. Development projects involve disturbance to the existing soil conditions, removal of existing trees, which result into soil erosion, instability and overall change in the microclimate and drainage pattern of the site. Erosion, by the action of water, wind and ice, is a natural process in which soil and rock material get loose and removed. There are two major classifications of erosion - (1) geological erosion, and (2) man-made erosion.

Geological erosion, includes soil-forming as well as soil-removing, has contributed to the formation of soils and their distribution on the surface of the earth. Man-made erosion, which greatly accelerates the natural erosion process, includes the breakdown of soil aggregates and the increases removal of organic and mineral particles. This could be caused due to clearing, grading or otherwise altering the land. Erosion of soils that occur at construction sites is man – made erosion.

#### *1.3.1.3 Preservation of vegetation and landscape*

Preservation of natural vegetation and protection of landscape during construction : Development projects involve disturbance to the existing soil conditions, removal of existing trees and overall change in the microclimate and drainage pattern. Measures to minimize hazardous effects should be put into effect as explained in this manual.

#### *1.3.1.4 Preservation of Air environment*

Air environment of the proposed site gets affected due to wind erosion, construction on site, transportation on site and heat island effect.

Dense urban areas tend to have higher air temperatures as compared to the surrounding low-rise rural areas because of the absorption and storage of a high percentage of radiation received by the built mass and minimised radiative heat losses from it. This gives rise to warmer air temperature in urban localities, which might reach 1-2deg.C more than that of the surrounding green areas. This phenomenon is called as the heat island effect.

Principle surfaces that contribute to the heat island effect include streets, sidewalks, parking lots, and buildings. Heat island effect can be minimized by use of shading or reflective surfaces. As mentioned, hard paved surfaces are one of the

major constraints of heat in land effect. In addition to causing heat island effect, hard pavements also reduce perviousness of site. Enhanced perviousness of site minimizes storm water runoff and is beneficial for localized aquifer recharge. This method aims to encourage design measures to minimize negative impacts of the paved areas. Design methodologies, which address the heat island phenomenon, affect the size and density and provide control for desired conditions, should be considered.

The transport related environmental aspects having impact on ambient air quality are explained in transport section (Section 3.2 and 3.3) of this manual.

#### *1.3.1.5 Hydrology on site*

This covers two aspects, i.e. natural hydrology and quality of water.

1. Natural hydrology: Undeveloped land has a certain capacity to absorb rainfall in the soils, vegetation and trees. The site before construction also has a natural drainage pattern. Clearing of vegetation and or construction of impervious surfaces (like roads, parking lots and buildings) reduce the capacity of land to absorb rainfall and increase the amount of storm water runoff and change the natural pattern of drainage. Increase in the frequency and magnitude of storm water runoff due to new developments can cause overflow of water on adjacent sites. As a result, the streambed and banks are exposed to highly erosive flows more frequently and for longer periods.
2. Quality of water: Storm water runoff volumes generated from imperviousness of the developed site is transported into the receiving waters via urban infrastructure like gutters, pipes and sewers. The storm water volumes contain sediment and other contaminants that have a negative impact on water quality, navigation and recreation. Storm water pollution sources include atmospheric deposition, vehicle fluid leaks, and mechanical equipment wastes. During storm events, these pollutants are washed away and discharged to receiving waters or get infiltrated inside the ground water.

#### *1.3.1.6 Waste management on site*

Pre construction, during construction and post construction guidelines for handling waste on site should be referred in Chapter 3, Construction waste management.

#### *1.3.1.7 Health and well being of construction workers*

Construction activities are large polluters of environment. Large volumes of suspended particulate matters are released during

construction work leading to air pollution. Unhygienic site sanitation facilities cause damage to environment and to health of the construction workers. Buildings sensitive to the environment and its resources should address these issues.

### 1.3.2 Recommendations and guidelines

#### *1.3.2.1 Design layout should ensure adequate solar access and ventilation.*

Depending upon the geographical latitude and sky conditions a precise analysis of the local climate; surroundings, urban development and surrounding terrain in relation to solar access, daylight availability and predominant air movement should be carried out. This would control minimum distances to be kept between the built up volume and open spaces. The design of the layout should allow for wind protection and solar access in winter, and at the same time provide adequate sun protection and ventilation in summer months. The size and density of the layout should provide desired comfort levels maximum from natural resources. Solar path analysis and wind pattern assessment should be carried out in the design stage that would help developers decide upon the alternatives for the type of layout and the proportion of the built volume and open space in the layout. For this section the submittals should be provided only to indicate the optimised layout of buildings on the site with respect to sun path and optimised solar access and availability of wind for natural ventilation. Following are the factors, which shall affect the layout of a sustainable design:

- Solar access

Solar access in the morphology of clusters can be understood in terms of utilization of direct (and not reflected or diffused) solar radiation mainly for day lighting and heat gain. Solar path analysis would help define the minimal distances between the buildings and the relations between built-up volume and open space.

- Building types

Choice of building types depends mainly on the cost of the land, infrastructure, land availability and suitability as per the requirements. Each building type and combination of different type forms a matrix of environmental conditions, which affect the macro as well as the microclimate around and inside the building. Building types may be detached/semi-detached, with courtyard /patio, high-rise, row house.

- Open spaces

The proportion of open space and its built-up edges should be designed such that it ensures winter solar access and summer ventilation. Vegetation may provide as shading and promote evaporative cooling. In hot dry climates, evaporative cooling through appropriately sized wet surfaces or fountains have a desirable effect.



### *1.3.2.2 Soil Conservation*

Topsoil removal and preservation shall be mandatory for development projects larger than 1, 00 hectare (Source: National Building Code 2005). Topsoil shall be stripped to a depth of 200 mm from areas proposed to be occupied by buildings, roads, paved areas and external services. Top soil shall be stockpiled to a height of 400 mm in pre - designated areas for preservation and shall be reapplied to site during plantation of the proposed vegetation. Measures should be applied to control erosion of preserved top soil. Top soil shall be separated from sub-soil debris and stones larger than 50 mm diameter.

Sites that have area less than 1,000 hectare, soil should be preserved if soil test reports predict that its nutrient rich and landscape consultant finds it usable for re application in post construction landscape design. In any case, measures on site should be adopted both during construction stage and post construction to minimise soil erosion through wind and storm water run off.

- Top soil characteristics:

Top soil consists of organic carbon that helps in soil aggregation and also improves water holding capacity of the soil which in turn helps in slowing down the flow of water through the soil. Basic inorganic nutrients present in the soil in adequate amount are required for healthy growth of vegetation. Thus, it is important to preserve top soil from soil pollution which is caused by construction materials and equipment during construction. The optimum levels for various organic and inorganic nutrients required for health vegetation growth is given below:

- Fertility:

The optimum level of organic carbon in soil ranges from 0.5-1.0 %. Maintain pH of 6.0–7.5; add lime where pH<6.0 to adjust to 6.5 or higher up to 7.5. Any soil having soluble salt content >500 ppm (parts per million) shall not be used for the purpose of landscaping. Ensure presence of basic inorganic nutrients i.e. nitrogen, phosphorus and potassium in adequate amount for healthy growth of vegetation. If application of fertilizers is required to enhance fertility, ensure proper and timely application.

Deficiency of organic and inorganic material can be improved by application of fertilizers, but care should be taken so as to avoid over fertilization. The soil should be tested from ICAR (Indian Council of Agricultural Research) accredited laboratory for primary plant nutrient and pH.

Table 1.4: Rating chart for soil test values of primary nutrients

Nutrient	Rating*			Recommended test**
	Low	Medium	High	
Organic carbon	<0.50	0.50-0.75	>0.75	Colorimetric method; Datta et al
Available nitrogen alkaline KMnO4-N (Kg/ha)	<280	281-560	>560	Kjeldahl apparatus
Available phosphorus Olsen's P (Kg/ha)	<10	11-25	>25	Olsen method
Available potassium Ammonium Acetate-K (Kg/ ha)	<120	121-280	>280	Ammonium acetate extraction method

\*Subject to minor variation as per local conditions.

\*\*Tests to be performed at ICAR (Indian Council of Agricultural Research)-  
accredited laboratory.

Source: Singh D, Chhoker, P K and Pandey, R N. 2000. Soil plant water analysis: a  
methods manual. New Delhi: Indian Agricultural Research Institute, 160 pp.

Landscape architect/horticulturist recommendation of improving deficient nutrient, timing of application of fertilizers and warning of excessive nutrient levels should be adopted. Judicious and timely applications of fertilizer are more beneficial to the plant's health and are less likely to cause environmental damage than infrequent, heavy, ill-timed applications

### 1.3.2.3 Soil preservation

It is important to consider and understand factors such as soil characteristics, climate, rainfall intensity and duration, vegetation and topography to predict the extent and consequences of soil erosion. Sedimentation occurs when soil particles are suspended in surface runoff or wind and are more dependable in streams and other water bodies.

Human activities during construction can accelerate erosion by removing vegetation, compacting or disturbing the soil, changing natural drainage patterns, and by covering the ground with impermeable surfaces (pavement, concrete, buildings). When the land surface is developed or "hardened" in this manner, storm water and snowmelt cannot seep into or "infiltrate" the ground. This results in larger amounts of water moving more quickly across a site which can carry more sediment and other pollutants to streams and rivers. (Source: Chapter 3, EPA) Disruption to the natural hydrology of the site could be minimised by reducing impervious cover, increasing on site infiltration and managing storm water run off.

The net flow reaching the storm water drain is called runoff. Systems should be employed on the site, such that the sediments from the run off are retained in the site, before the storm water goes into the drain. This calculation can be carried out by multiplying imperviousness and quantity of rainfall falling on the surface. (Refer section 2.9 on rainwater harvesting). This quantity should be used to quantify the capacity for sedimentation basin.

The soil conditions and the ground slope determine the impermeability factor. Impermeability factor is the proportion of the total rainfall received on the surface which gets discharged into the storm water drainage, after the initial absorption though evaporation, vegetation and other losses. The net flow reaching the storm water drain is called as runoff.

Imperviousness (%) is calculated as:

Impervious area on ground and roof (m<sup>2</sup>) = Surface area X  
Runoff coefficient

Imperviousness (%) = Total Impervious area / Total site area

Runoff coefficient for various surfaces is as follows:

Table 1.5 Runoff coefficients of various surfaces

Surface type	Runoff coefficient
Roofs conventional	0.95
Roof garden <100 mm thick	0.50
Roof garden 100 –200 mm thick	0.30
Roof garden 200 -500 mm thick	0.20
Roof garden >500 mm thick	0.10
Concrete/ Kota Paving	0.95
Gravel	0.75
Brick Paving	0.85
Vegetation	
Slope 0-1%	0.10
Slope 1% to 3%	0.2
Slope 3% to 10%	0.25
>Slope 10%	0.3
Turf slopes	
0% to 1%	0.25
1% to 3%	0.35
3% to 10%	0.4
> 10%	0.45

(Source LEED version 2.1)

The following sections describe stabilization practices and structural practices for erosion and sediment control. Using the

measures to control erosion and sedimentation is an important part of storm water pollution and prevention. Details of storm water management could be referred in section 2.8, chapter 2. National Building Code restricts the imperviousness of sites, which shall not be exceeded.

NBC (National Building Code 2005) standards for imperviousness factor applicable to different types of area.

Table 1.6: NBC Standards for imperviousness

Type of area	Imperviousness factor (%)
Commercial and industrial areas	70-90
Residential areas (high density)	60-75
Residential areas (low density)	35-60
Parks and underdeveloped areas	10-20

Measures for soil preservation and erosion control are well established, and in this document have been brought together.

*Measures and recommendations to preserve top soil :*

During construction soil becomes unconsolidated due to removal of stabilizing material such as vegetation and disturbance of stabilized existing grade resulting in loss of top soil and also deposition in undesirable places. A soil erosion and sedimentation control plan should be prepared prior to construction. The soil erosion, sediment control and storm water practices mentioned in this document should be incorporated depending upon the site characteristics to control soil erosion and loss of top soil during construction.

Mitigation options

1. When opening the site, care should be taken to keep vegetation clearing at a minimum.
2. To keep the damage to topsoil minimum, excavators must be used for construction. The excavated material such as topsoil and stones should be stacked at safe places for reuse at a later stage of construction.
3. Prevent soil erosion for large sites during construction by providing sedimentation basin, contour trenching, mulching, as required. Some generic soil erosion control measures are described below:

Soil erosion and sedimentation control measures

1. On the proposed site the net imperviousness of the site should not exceed the imperviousness factor as

prescribed by the National Building Code 2005; Part 9 (Plumbing services) Section 5.5.11.2.1.

2. Preserving existing vegetation or revegetating disturbed soils is one of the most effective ways to control soil erosion.

There are two types of soil erosion control:

1. Temporary controls – provide cover to the soil for a short period of time, till the permanent measures are adopted. These are usually applicable during construction.
2. Permanent controls – These measures are incorporated on soil, when activities that disturb the soil are over. These measures could be applicable post construction in the proposed landscape plan.

#### *Temporary control measures*

1. Temporary seeding: This is carried out to reduce erosion and sedimentation from disturbed areas that will not be stabilised for long period and where permanent plant growth is not appropriate. Temporary seeding means growing vegetative cover for a short period of time on disturbed site areas that are prone to soil erosion. Fast growing grasses are used in this system whose root systems hold the soil together so that they are not carried away by storm water run off and wind. Temporary seeding also helps in reducing the problem of dust from bare soil due to construction. Temporary seeding should be performed on areas which have been disturbed during construction and which are likely to be disturbed after a few weeks. For this time gap the top soil should be preserved from erosion through temporary measures like temporary seeding.

*Application:* This method of soil stabilization heavily depends upon the season and rainfall rate for success. In semi-arid regions the climate prevents fast plant growth particularly during dry seasons and therefore other temporary measures such as mulching, geo-textiles etc should be considered. Information on best seed mixes and soil conditioning methods should be carried out in consultation with a landscape architect. Seeding on slopes of 2:1 or more, in adverse soil conditions, regions where hot or dry season is expected or where heavy rains are expected should be followed by spreading mulch.

2. Earth dikes and contour trenching: An earth dike is a ridge and channel arrangement constructed parallel to the contours along the face of the slope at regular intervals on the lengths and slopes greater than 10% (1:10). They are used to protect the work areas from upslope runoff and to divert the sediment –laden water

to sediment traps. They are used for reducing runoff velocity, increasing the distance of overland runoff flow, and to hold moisture and minimize sediment loading of surface runoff. The dike consists of compacted soil and stone, riprap or vegetation to stabilise the channel. Improper design of earth dikes should be avoided therefore it is important that the landscape consultant designs it right according to the conditions of the site.

*Application:* Earth dikes find its application above disturbed existing slopes to prevent the flow of water above the slope. It could be used below slopes to divert excess runoff to stabilised outlets, and at the periphery of construction area to retain the sediments inside the site.

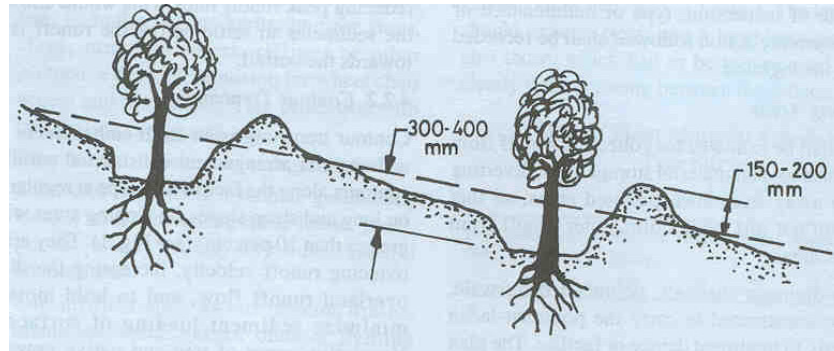

**Figure 1.1**

(Source: www.epa.com)

3. **Mulching:** Mulch is simply a protective layer of a material that is spread on the top of the soil. Mulching is a temporary soil stabilization technique. Mulches can either be organic, such as grass, hay, straw, wood chips, and similar materials, or inorganic, such as stones and brick chips. Mulching should be used with seedlings and plantings in steep slope areas (slopes > 33%). Steep slopes are prone to heavy erosion. Netting or anchoring should be used to hold it in place. Other surface runoff control measures like contour terracing to break up concentrated flows shall be installed prior to seeding and mulching. In addition to stabilizing soils, mulching will reduce the storm water runoff over an area. Mulching when done with seedlings or plantings, aids plant growth by holding the seed, fertilizers, and top soil in place. It retains moisture and insulates the soil against extreme temperatures. *Application:* Mulching provides immediate protection in areas which need heavy erosion and temporary seeding is not applicable because of season and climate. Mulching should be anchored to the ground to hold the mulch in place, where the land has steep slopes. Mulch is required for seeded and planted areas where slopes are steeper than 2:1. (Source: EPA, Chapter 3 – Sediment and erosion control).

4. **Geotextiles:** Geotextiles are porous fabrics which are manufactured by weaving or bonding fibres made from synthetic materials. Geotextiles like nets when combined with mulch act as stronger mulch. Nets are made from jute or other wood fibres and can be used to stabilise soil while plants are growing. Geotextiles could also be used to stabilise the flow on channels and swales. It could also be used to protect seedlings until they become established.

*Application:* Geotextiles could be used alone as a soil stabilising technique. When used alone it could be used as a mat to stabilise the flow on channels and swales. Matting could also be used to stabilise recently planted slopes to protect the seedlings till they get established. Geotextiles could also be integrated for embankment stabilisations through rip rap where extreme steep slopes exist that are subject to storm water run off. Fabric as a filter could be used to protect the soil beneath from effects of flowing water.

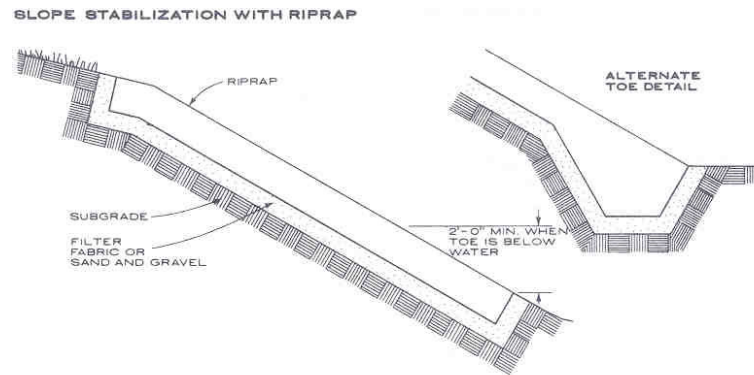

Figure 1.2

Source: [www.epa.com](http://www.epa.com)

5. **Silt fence:** A silt fence is a temporary measure for sedimentation control. This system consists of a filter fabric which is supported by posts. The lower edge of the fence is vertically trenched and covered by backfill. This system is most effective where there is overland flow. It controls sediment run off from the site from entering into the receiving waters. For large areas, silt fence is not appropriate to control the run off; however, it could be used in combination with other erosion and sediment control measures. The sediments should be removed and disposed once it is one third or one half the height of fence.

*Application:* A silt fence is used to detain sediments from a small drainage area. A silt fence should be installed prior to major soil disturbance in the drainage area. The fence should be placed at the bottom of the

slope and perpendicular to the direction of flow. It could be used at the boundary end of construction area.

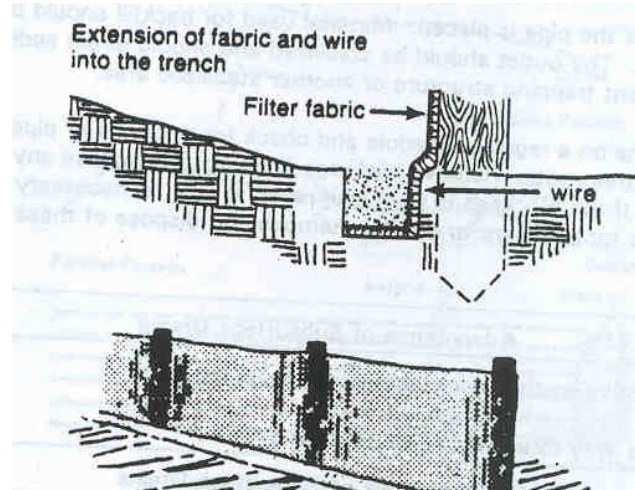

Figure : 1.3

6. Sediment trap: A sediment trap can be constructed by excavating a pond across a low-lying area on the site. The trap should retain the run off enough to allow the sediment to settle before they are released. The outlet is constructed using large stones and aggregate to slow down the release of run off. This system is appropriate for small drainage areas not more than 10 acres (Source: EPA, Chapter 3 – Sediment and Erosion Control). The volume of the storage required depends upon the surface type and rainfall intensity. Please check rainwater harvesting section to determine the volume of storm water run off and design capacity of sediment trap.

*Application:* A temporary sediment trap could be used in conjunction with swales, contour trenches, earth dikes, diversion channels. Sediment traps are suitable for small drainage areas, less than 10 acres. The traps should be maintained till the site \*area is permanently stabilised through vegetation and or when permanent structures are in place.

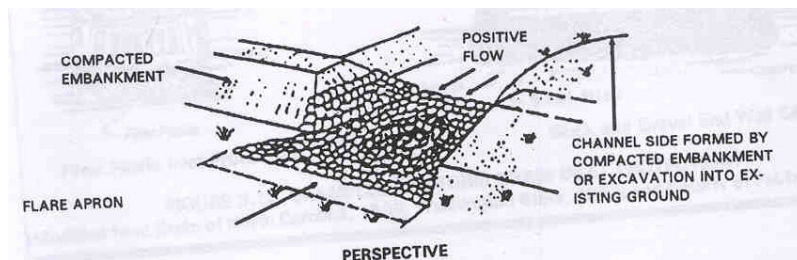

Figure 1.4



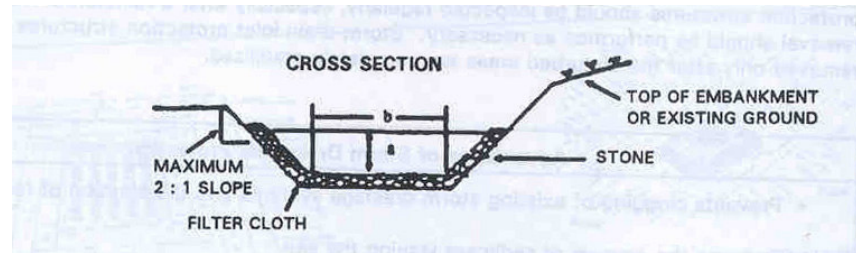

Figure 1.5

7. Post landscape practices: The soil conservation, sediment control and storm water management practices given below shall be practiced after construction is complete.
8. Top soil laying: Placement of topsoil or other suitable plant material over disturbed lands should be carried out to provide suitable soil medium for vegetative growth. Prior to spreading the topsoil, the sub-grade shall not be loosened to a depth of 50 mm to permit bonding. Topsoil shall be spread uniformly at a minimum compacted depth of 50 mm on grade of 1:3 or steeper slopes; a minimum depth of 100 mm on shallower slopes is essential. A depth of 300 mm is preferred on relatively flatter land. If top soil is brought from another site, it is important that the texture of new soil is compatible with sub soils on site. Topsoil stock piled on site should be preserved from erosion through temporary seeding, mulching etc.
9. Permanent soil stabilisation:
 

Permanent planting: The most effective way to prevent soil erosion, sedimentation and to stabilise disturbed and undisturbed land is through the provision of vegetative cover by effective planting practices. The foliage and roots of plants provide dust control and a reduction in erosion potential by increasing the infiltration, trapping sediment, stabilizing soil and dissipating the energy of hard rain. Permanent seeding of grass and planting trees not only provide permanent stabilisation of soil but also reduce sedimentation run. Permanent seeding and planting is appropriate in all those areas where land is cleared and long lived plant cover is desired. To establish the plants however, it is important that the trees are local and need low maintenance.

*Application:* Permanent planting is appropriate in all those areas where the land is cleared and long lived plant cover is desired. The technique is applicable to all soil types. Areas where permanent seeding and planting are particularly beneficial are buffer areas, vegetated swales, steep slopes and stream banks, flood plains,

wetlands, and other areas where erosion control would be difficult to establish, install and or maintain.

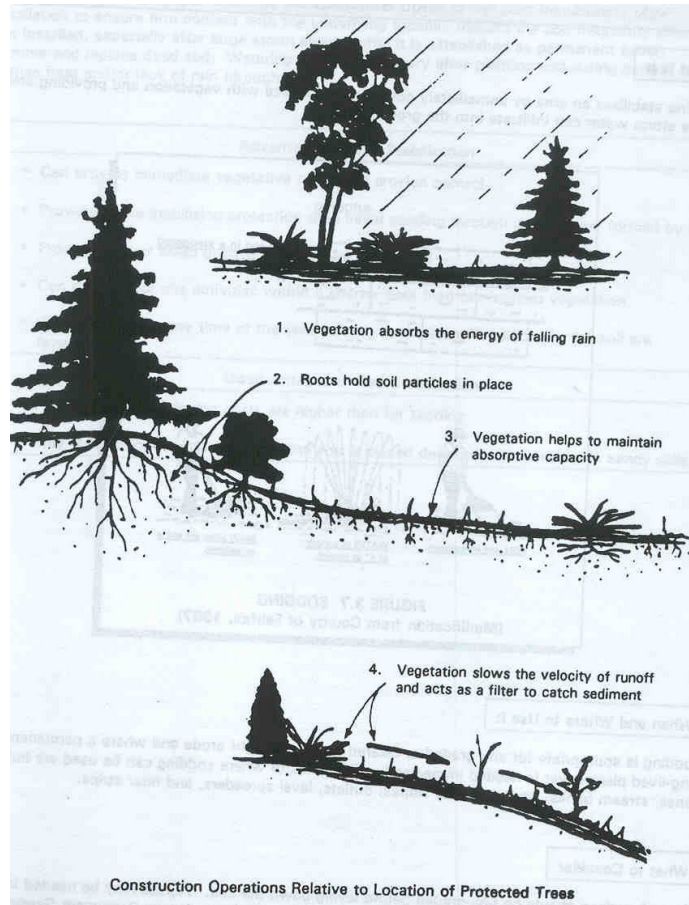

**Figure 1.6**

Structural Erosion and sedimentation control measures: Structural practices used in sediment and erosion control divert storm water flows away from exposed areas, convey run off, prevent sediments from moving off site. These controls could be either temporary or permanent measures to control erosion. Following are some of the measures: For common drainage locations that serve an area with 10 acres pr more at one time, a temporary (or permanent) sediment basin providing 3,600 cubic feet of storage per acre drained, or equivalent control measures, shall be provided where attainable until final stabilisation of the soil.

Earth dikes and contour trenching: An earth dike is a ridge and channel arrangement constructed parallel to the contours along the face of the slope at regular intervals on the lengths and slopes greater than 10% (1:10). They are used to protect the work areas from upslope runoff and to divert the sediment – laden water to sediment traps. They are used for reducing runoff velocity, increasing the distance of overland runoff flow, and to

hold moisture and minimize sediment loading of surface runoff. The dike consists of compacted soil and stone, riprap or vegetation to stabilise the channel. Improper design of earth dikes should be avoided therefore it is important that the landscape consultant designs it right according to the conditions of the site.

*Application:* Earth dikes find its application above disturbed existing slopes to prevent the flow of water above the slope. It could be used below slopes to divert excess run off to stabilised outlets, and at the periphery of construction area to retain the sediments inside the site.

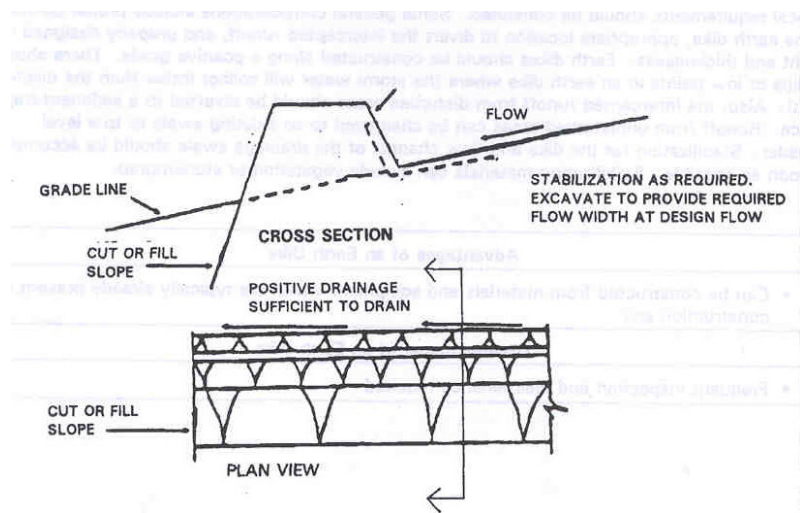

**Figure 1.7**

**Drainage swales:** Drainage swales are vegetated channels with a slope similar to that of standard storm drain channels (less than 0.6 percent), but wider and shallower to maximize flow residence time and promote pollutant removal by filtration through the use of properly selected vegetation. It has to be designed to trap particulate pollutants (suspended solids and trace metals), promote infiltration and reduce the flow velocity of the storm water runoff. It must be integrated with storm water system. (Source: National Building Code 2005)

*Application:* A drainage swale is applied where water run off is conveyed without causing soil erosion. Drainage swales can be used to convey runoff from the bottom or top of a slope. For swales that are draining water from a disturbed area, the outlet should be sediment trapping device prior to its release.

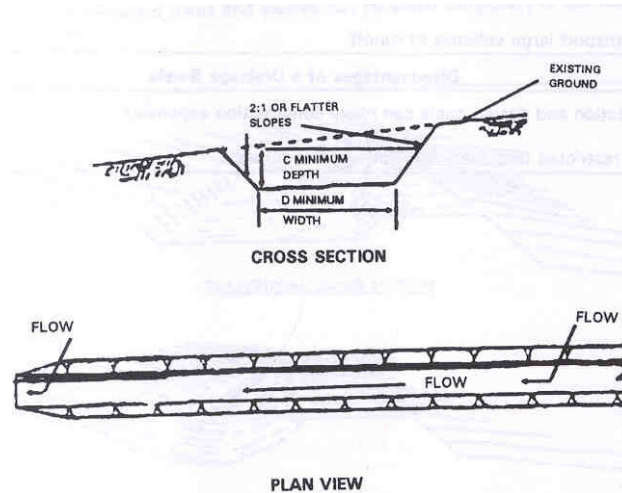

**Figure 1.8**

**Sediment basin:** Sediment basins are appropriate for disturbed site areas larger than 5 acres. A sediment basin could be defined as a settling tank with a controlled storm water release structure which is used to collect and store sediment produced from disturbed sites where construction activities are carried out. It is important that the basin size should be calculated to handle the maximum amount of drainage expected from the site. The embankment which forms the sedimentation pool should be compacted and stabilised with vegetation. The outlet of the basin should be as far as possible from the entrance to provide maximum retention time. The outlet should be a gravel outlet to slow down the run off and provide extra sediment filtration.

**Application:** These are suitable for large disturbed construction sites larger than 5 acres. The biggest advantage of sedimentation basins is that a well built sedimentation basin that is large enough to handle post construction run off volume could be converted into a permanent storm water management structure. Sedimentation basins could be used in conjunction with seeding and mulching.

**Rain Water Harvesting Structure:** Different types of rain water harvesting structures also act as erosion control devices to preserve soil and water. For details on different types of rain water harvesting structures, refer section 2.9.

10. Preservation of vegetation and landscape on site
  - Pre construction and during construction measures for protection and preservation of landscape
  - Measures for the prevention of soil erosion, sediment control and management of storm water shall be implemented as follows:

Timing of construction: Construction work and erosion control applications shall be scheduled and sequenced during dry weather periods when the potential for erosion is the lowest. Slope protection techniques to control erosion shall be used when construction during wet season is unavoidable. Sedimentation collection systems, drainage systems, and runoff diversion devices shall be installed before construction activity. The Architect / Landscape Architect / Engineer-in -charge shall monitor the site conditions and progress of work and schedule appropriate timing and sequencing of construction.

Preservation of existing vegetation:

- When opening the site, care should be taken to keep vegetation clearing at a minimum.
- Vegetation cleared should be monitored and documented in terms of area, species, densities / numbers of trees etc.
- Compensatory forestation should be practiced wherever vegetation removal has been done
- Mark existing vegetation on site in surveys and follow detailed guidelines of tree preservation as per draft National building code; Part 10:Landscaping, signs, and outdoor display structures.

Protection of existing vegetation (including trees, shrubs, grasses and other plants) where possible, by preventing disturbance or damage to specified areas during construction is recommended. Preservation of natural vegetation acts a permanent control measure. It minimises erosion potential, protects water quality and provides aesthetic benefits. The technique is applicable to all soil types. Areas where preservation of existing vegetation are particularly beneficial are buffer areas, vegetated swales, steep slopes and stream banks, flood plains, wetlands, and other areas where erosion control would be difficult to establish, install and or maintain.

This practice minimizes the amount of bare soil exposed to erosive forces. All existing vegetation shall be marked on a site survey plan. A tree survey in prescribed format shall be carried out as indicated in Table-3. The landscape plan should indicate trees, which have been preserved, and also those, which had to be transplanted or removed clearly differentiating between these three categories.

*Tree survey format*

---

Serial No. identifiable in survey plan	Botanical name	Common name	Girth	Height	Spread	Condition	Protected <sup>1/</sup> preserved <sup>2/</sup> transplanted <sup>3/</sup> removed <sup>4</sup>
--	-------------------	----------------	-------	--------	--------	-----------	--

---

Trees retained on the project site shall be protected during the construction period by following measures:

- Damage to roots shall be prevented during trenching, placing backfill, driving or parking heavy equipment, dumping of trash, oil, paint, and other materials detrimental to plant health by restricting these activities to outside the area of the canopy of the tree.
- Avoid cut and fill in the root zones, through delineating and fencing the drip line (the spread limit of a canopy projected on the ground) of all the trees or group of trees. Separate the zones of movement of heavy equipment, parking, or excessive foot traffic from the fenced plant protection zones.
- Trees will not be used for support; their trunks shall not be damaged by cutting and carving or by nailing posters, advertisements or other material.
- Lighting of fires or carrying out heat or gas emitting construction activity within the ground, covered by canopy of the tree is not to be permitted.
- Young trees or saplings identified for preservation (height less than 2.00m, 0.10m trunk girth at 1.00m height from finish ground, 2.00m crown diameter) within the construction site have to be protected using tree guards of approved specification.
- Existing drainage patterns through or into any preservation area shall not be modified unless specifically directed by the Landscape Architect / Architect / Engineer-in-charge.
- Existing grades shall be maintained around existing vegetation and lowering or raising the levels around the vegetation is not allowed unless specifically directed by the Landscape Architect / Architect / Engineer-in-charge.
- Maintenance activities shall be performed as needed to ensure that the vegetation remains healthy.
- The preserved vegetated area shall be inspected by the Landscape Architect / Architect / Engineer-in-charge at regular intervals so that they remain undisturbed. The date

---

<sup>1</sup> Protected trees are the trees that are undisturbed during the construction.

<sup>2</sup> Preserved trees are the ones that are uprooted and preserved for re-plantation at original location after the construction activity is over.

<sup>3</sup> Transplanted trees are the trees that are uprooted and replanted at different location.

<sup>4</sup> Removed trees are the ones that are uprooted for construction.

of inspection, type of maintenance or restorative action followed shall be recorded in the logbook.

**Staging areas:** Staging is dividing a construction area into two or more areas to minimize the area of soil that will be exposed at any given time. Staging should be done to separate undisturbed land from land disturbed by construction activity and material storage. Measures shall be followed for collecting drainage water runoff from construction areas and material storage sites; diverting water flow away from such polluted areas, so that pollutants do not mix with storm water runoff from undisturbed areas. Temporary drainage channels, perimeter dike/swale, etc. shall be constructed to carry the pollutant-laden water directly to the treatment device or facility (municipal sewer line). The plan shall indicate how the above is accomplished on-site, well in advance of the commencing of the construction activity.

**Spill prevention and control:** Spill prevention and control plans should be made, clearly stating measures to stop the source of the spill, to contain the spill, to dispose the contaminated material and hazardous wastes, and stating designation of personnel trained to prevent and control spills. Hazardous wastes include pesticides, paints, cleaners, and petroleum products.

**Preservation of top soil:** During construction, soil becomes unconsolidated due to removal of stabilizing material such as vegetation and disturbance of stabilized existing grade resulting in loss of top soil and also deposition in the undesirable places. A soil erosion and sedimentation control plan to be prepared prior to construction and should be applied effectively. Measures for preservation of topsoil are mentioned in the Soil resource section above.

**Planting for shelter and soil conservation:** The use of vegetation for controlling wind is widely recognised as an effective way of conserving soil and reducing erosion by wind. Vegetation may therefore be used for modifying the microclimate, by obstructing, guiding, deflecting or filtering wind current. Vegetation areas designed to fulfil these general functions are usually classified as windbreakers and shelterbelts. The term windbreaker refers to protective planting around gardens and orchards. Windbreakers generally consist of single or double row of trees. The term shelterbelt refers to extensive barrier of trees with several rows of trees. Plant species are chosen with particular regard to their physical and growth characteristics, and their effectiveness in achieving the desired results. Both windbreakers and shelterbelts have considerable visual impact in the landscape in which they are situated, they therefore need

to be designed so that they make a positive visual and aesthetic contribution to their environment.

Function: Windbreaker and shelterbelts are very important for agriculture under arid and semi-arid conditions; they also fulfil essential micro-climatic functions in rural and urban environments. Benefits accruing from plantation of shelter planting can be listed as follows (Sitaram Rao 1979, Leloup 1955):

- Reduction in wind velocity resulting in the arrest of movements of sand and soil particles.
- Prevention of soil erosion.
- Modification of micro-climate; change in air temperature are moderated.
- Protection of crops from being blown by high winds
- Protection of livestock
- Reduction in evaporation of soil moisture. Increase in soil moisture content varies from 3 to 7.8 %. Water loss due to evaporation is lessened. This is estimated to increase production by 15%.
- Increase in soil moisture due to greater dewfall in sheltered areas has been found to be 200 per cent higher than on exposed ground. Heaviest dew fall is over a distance of 2-3 times the height of the shelterbelt.
- Beneficial effect on growth of plants that are affected by high winds.
- Extensive shelterbelts can also be used to augment the supply of fuel in rural areas.
- The zone of influence of shelterbelt on crop yield extends to a distance of 20 times the height of the belt, with the maximum effect being observed 10 times the height of the tree belt, on the leeward side.

Recommendations for planting design considerations:

Plant materials are a very important component of landscape design, and planting design is integral to the landscape plan. Designing with plants requires awareness and knowledge of a broad range of aspects including (a) Ecology (b) Botany (c) Horticulture (d) Aesthetic Value (e) Growth and Survival and (f) Use of Plants to fulfill environmental design functions.

Plant material

The major sets of factors that influence the choice of plant material are related to the characteristics, both botanical and physical of plant material and the context in which the plant material is to be used. The inter-relationship of these sets of factors is the basis for developing a sound approach to the process of designing with plants.



## Physical and Botanical Characteristics of Plant Material

The information on plant material should be available in a systematic format to include definition, significance and design implications of the following aspects:

- Nomenclature, Latin and common
- Origin, family, natural habitat
- Growth characteristic, form as a function of habit
- Physical characteristics, e.g. bark texture, foliage etc.
- Propagation and maintenance
- Use in Landscape Design

Vegetation Types: Evergreen and deciduous:

Some examples of the functional implications of using evergreen and deciduous plant material for specific situations are:

- Evergreen trees for:
  - i. places requiring shade throughout the year
  - ii. strong visual screening
  - iii. part of windbreak or shelter planting
  - iv. areas where leaf litter is to be discouraged
- Deciduous trees for:
  - i. greater visual variety
  - ii. partial visual barrier
  - iii. areas where under-planting is to be encouraged (e.g. grass)
  - iv. emphasis on branching and flowering pattern.
  - v. areas where shade is not required throughout the year.

Growth rate and age of the vegetation: Growth rate is directly related to the life-span of a tree and slower growing trees have a life-span extending to hundreds of years. The fast growing trees to the exclusion of other slower growing varieties is not recommended. Landscapes are developed to sustain future generations; slow growing & native trees must be included in all major planting schemes, especially those related to institutional campuses and large urban development. However, fast growing species do have a limited role, and are appropriate in situations where:

- Quick effects are required-for instance in windbreaks and shelterbelts.
- Immediate results with regards to stabilization of soil etc. are necessary as for instance in soil conservation schemes.
- As 'nurse plants' to protect slower growing sensitive species when necessary.

The slower growing species would generally be appropriate in situations where sustained environmental benefits are required

such as roadside planting, campuses, townships, industrial areas, and other public landscapes.

**Maintenance:** The success of a designed landscape depends upon the growth of vegetation over an extended period of time; therefore maintenance of landscape is also a design component. Maintenance needs and a practice in any given situation arises out of the inter-relationship between the growth requirements of plant material chosen and the environmental conditions existing on site.

The likely degree of maintenance should be assessed based on the following:

- Scale of the Design Project
- Financial and manpower resource
- Availability of manures
- Future intensity of site
- Environmental conditions

In small-scale projects such as gardens and small parks the natural environmental conditions can be changed and maintained in this changed state by management practices such as irrigation and application of fertilisers. The choice of plant species is therefore not very strictly limited by the existing environmental conditions. On larger scale schemes, such as very large parks, campuses and townships, this kind of intensive maintenance is not possible, and any planting scheme, which does not take this into consideration, fail. The process of choosing plants must therefore respond to the existing environmental conditions and also in such cases the choice of plant material is restricted by these conditions and suitable species are limited. The type of treatment adopted also serves as a guide to the degree of maintenance required:

Table 1.7: Degree of maintenance required (for vegetation)

a)	Low Maintenance	The lowest degree of maintenance is usually possible in areas treated with native species of trees only. A slightly higher degree is necessary where native shrubs are also used, as these may require pruning
b)	Medium	Areas treated with a mixture of native and exotic trees Exotic shrubs and trees
c)	High	Exotic shrubs and ground covers Lawns and maintained grass areas Annual flowers, special schemes

## 1.4 Mitigation options for controlling air environment

Ambient air quality has already been tested during the site selection process. In the site analysis process, the aim is to ensure that ambient quality is not deteriorated due to wind erosion, dust generation on site during construction, increased traffic generation and heat island effect due to post construction landscape design.

### 1.4.1 Mitigation measures for wind erosion

As already mentioned, some of the basic functions of windbreaks and shelterbelts in arid and semiarid areas are to conserve soil, improve productivity, and reduce erosion by wind. The latter is a natural phenomenon in lands having very little rainfall (125mm-250mm) and in areas adjoining a river, lake or sea. Wind erosion is a serious problem in areas where the ground is virtually bare and devoid of vegetation. To understand the techniques used for the control of wind erosion it is important to know how eroding action by wind occurs:

Factors, which influence the degree and kind of wind erosion, are as follows (Rama Rao 1974):

Table 1.8 Factors influencing degree and kind of wind erosion

Features of wind	Speed, direction, temperature, humidity, burden carried
Character of surface	Rough or smooth plant cover, obstruction, temperature
Topography	Flat, undulating broken
Character of soil	Texture, organic matter, moisture content

Techniques:

The principal method of reducing surface velocity of wind, upon which depends the abrasive and transportation capacity of wind, is by vegetation measures (Raina Rao 1974). Vegetation methods are found to be most effective in the form of windbreaks and shelterbelts. In aerodynamic terms, these provide protection as follows (Konda Reddy 1979):

- Sheltered zone on the leeward side extends to approximately 15-30 times the height of the belt
- A dense belt provides greater shelter immediately to leeward but the sheltered area is not as extensive as when a more permeable zone of vegetation is provided.
- Porosity is important in the effectiveness of shelterbelt and proper selection of free species is necessary. Porosity near ground level is desirable.
- Effectiveness of shelter planting depends more on height and permeability than on width. The width influences the general microclimate but above a certain minimum width, it does not effect greater reduction in wind velocity.

Protection obtained varies in relation to height (H) of shelterbelts (FAO 1957)

Distance H - wind reduced by 90%

Distance 2H - wind reduced by 75%

Distance 5H - wind reduced by 50%

Distance 10H- wind reduced by 20%

This indicates that it is better to have several windbreaks printed 5H to 6H apart rather than large forest stands with wide open spaces in between.

Profiles:

A belt which rises and falls abruptly on windward and leeward sides is said to be more effective. Smaller trees and shrubs should occupy the inter-spaces between the tall trees. Some authorities (Rama Rao 1974) maintain that triangular section of shelterbelt planting is more effective.

The depth of the shelterbelt should be approximately ten times its height. This is, however, only a thumb rule. Much lesser widths of 20 m - 30 m have also been found to be useful in particular situations; 15 m should be considered as a minimum width.

Apart from factors such as climate, soil, fast rate of growth, one of the more significant considerations in choosing species for shelter planting is the possibility of a particular species serving the dual role of wood-production (for fuel, fodder) as well as shelter.

#### 1.4.2 Mitigation measures to control air pollution by plants

Air Pollution may be caused by areas or point sources such as cities, industrial areas, factories or by linear sources such as highways. Vegetation buffers can minimize the build-up of pollution levels in urban areas by acting as pollution sinks. Studies have established that air pollution, smoke and sulphur di oxide leads to an exacerbation of chronic respiratory diseases and they are linked to lung cancer, pneumonia, tuberculosis, chest disease in children, stomach cancer and cardiovascular diseases. Lead from vehicle exhausts may have an adverse effect on mental health of children, asbestos from disintegrating clutch and break linings has been considered as a casual factor in lung cancer.

##### 1. Effect of Plants

Plant leaves function as efficient gas exchange system. Their internal structure allows rapid diffusion of water soluble gases. These characteristics allow the plant to respire and photosynthesise, and they can also remove pollutant from the air. Some of the beneficial results of plantations may be

- They are good absorbers of sulphur di oxide.

- Parks with trees have an SO<sub>2</sub> level lower than city streets.
- Roadside hedges can reduce traffic generated air borne lead, on leeward side.
- Heavy roadside planting in the form of shelterbelts can result in reduction in airborne lead
- Complete dust interception can be achieved by a 30 m belt of trees. Even a single row of trees may bring about 25 percent reductions in airborne particulate.

#### 1. Choosing plants

The three main criteria for selection of plants may be:

- Trees, shrubs should have dense foliage with a large surface area, because leaves absorb pollutants.
- Evergreen trees are found to be more effective.
- The species chosen must be resistant to pollutants, particularly in the early stages of their growth.

The following species may be examined for their likely potential for pollution control:

- Acacia arabica (Babul)
- Citrus species
- Dyospyros species
- Ficus bengalensis (Banyan)
- Ficus religiosa (Peepal)
- Lillium spp. (Lily)
- Polyathia lotigifolia (Ashok)
- Tamarindus indica (Imli)
- Thuja occidentalis (Cedar)
- Prospis Juliflora (Mesquite)
- Zizypus jujuba (jujuba), etc.

Filtering of pollutants is most effective when plants are close to the source of pollution. The design of shelterbelts against pollution is similar to those for protection from wind. They should be permeable to encourage air turbulence and mixing within the belt. There should be no large gaps. The profile should be rough and irregular and should present a tall vertical leading edge to the wind. Spaces should be left within the shelterbelt to allow gravity settlement of particles.

#### Applications

Air pollution shelterbelts may be used to protect sensitive land uses from air pollution. For instance school playgrounds, children play area and residential estates close to major roads may be so protected. Shelterbelt protection may also be provided for hospitals, institutions, etc, where the vegetation may also be a visual screen and partial noise barrier. Vegetation may also be used where the existing means of pollution control have proved inadequate.

### 1.4.3 Mitigation measures for dust control

1. Paving - Paving is a more permanent solution to dust control, suitable for longer duration projects. High cost is the major drawback to paving. Paving may be an appropriate solution for access roads to large development projects, where the road can eventually be incorporated in the overall plan for the area. Another appropriate use of paving might be "maintenance" projects, such as parking lots and material storage areas, where gravel cover is not adequate for dust control or erosion.

Applying Dust Suppressants - There are many types and brands of chemical dust suppressants which work by binding lighter particles. Biodegradable suppressants may be applied as a surface treatment to "seal" the top of an area, or may be applied using a mixing method that blends the product with the top few inches of the land surface material. It is important to note that used oil may NOT be used as a suppressant.

2. Graveling - Applying locally found gravel to access roads and lots adds a protective layer over the exposed soil and helps control dust generation in some situations. It is important that gravel contain a minimal percentage of fines and clean gravel be added periodically, as the fines migrate to the surface and create dust.
3. Using Water Sprays - Water spray, whether through a simple hose for small projects, or a water truck for large projects, is an effective way to keep dust under control. Misting systems and sprinklers are mechanisms that can be employed to deliver continuous moisture. Keep in mind, however, that fine mists should be used to control fine particulate. The size of the water droplet must be comparable to the size of the dust particle so that the dust adheres to the water.

There are several constraints to using water. Water can be very costly for larger projects in comparison to other methods. Heavy watering can also create mud, which when tracked onto paved public roadways, must be promptly removed. Also, there must be an adequate supply of clean water nearby to ensure that spray nozzles don't get plugged.

4. Reducing Vehicle Speed - High vehicle speeds increase the amount of fugitive dust created from unpaved areas. Reducing the speed of a vehicle to 20 kmph can reduce emissions by a large extent. Speed bumps are commonly used to ensure speed reduction. In cases where speed

reduction cannot effectively reduce fugitive dust, it may be necessary to divert traffic to nearby paved areas.

5. Material storages / warehouses – Care should be taken to keep all material storages adequately covered and contained so that they are not exposed to situations where winds on site could lead to dust / particulate emissions. Fabrics and plastics for covering piles of soils and debris is an effective means to reduce fugitive dust. However, these materials can be costly and are subject to degradation from the sun, weather, and human contact. Straw and hay can also be used to cover exposed soil areas, although they can be disturbed by wind and vehicles.

Reducing Wind Speed at Ground Level - Plants, bushes, trees, earthen banks and rock walls provide natural, and more permanent, windbreaks. Because enclosures and wind screens can be costly, the feasibility of using this type of control must be determined on a case-by-case basis.

Restricting Activities During High Wind Periods - Rescheduling work around especially windy days potentially can be one of the least expensive and easiest dust control measures, provided work crews are not idled and/or this is a project with significant time constraints. Limited use of rescheduling might be appropriate in extreme weather conditions, given the availability of other tasks for employees.

The high visibility of certain projects and population impacted should be taken into consideration when scheduling dust producing work. Evenings and weekends are possible alternatives for scheduling work in business and school locations; while mid day may be more appropriate for residential areas because people are more likely to be away from home.

Cleaning Up Spills Promptly - Spills of dirt or dusty materials must be cleaned up promptly so the spilled material does not become a source of fugitive dust.

When cleaning up the spill, ensure that the clean-up process does not generate additional dust. Similarly, spilled concrete slurries or liquid wastes should be contained / cleaned up immediately before they can infiltrate into the soil / ground or runoff in nearby areas.

6. Mitigation measures to reduce heat island effect:  
Planting trees, bushes, or a properly planned landscaping can help reduce the heat island effect by reducing ambient temperatures through evapo-transpiration. Plant vegetation around the building to intercept solar radiation and to shade the walls and windows of buildings (with S, SW or SE exposure) to

prevent heat gain. This would also help in reducing air-conditioning load/use.

Use light coloured, reflective roofs having an SRI (solar reflectance index) of 50% or more. The dark coloured, traditional roofing finishes have SRI varying from 5% to 20%. The fine example of higher SRI is the use of broken china mosaic, light coloured tiles as roof finish, which reflects the heat off the surface because of high solar reflectivity, and infrared emittance which prevents heat gain.

Use commercially available, high solar reflective (albedo) roof coatings or heat reflective paints on roofs used to shade paved areas. Don't use stone mulches such as fine gravel, crushed granite or pebbles in unplanted areas immediately adjacent to buildings, as they can heat up, reflect solar radiation inside, and also cause glare.

Use high albedo or reflective pavements to keep parking lots, pavements and inside roads cool because the increase in albedo decreases the pavement temperature approximately by 8°F for a change in albedo of 0.1.

Use light coloured aggregates or 'whitetop' the pavements with 50 mm thick layer of cement concrete. Stabilize the pavements with porous or permeable materials such as sand, crushed bricks, broken mosaic tiles or stones where the soil is stable or the traffic load is quite low. Recycled materials such as demolished concrete (rubble), broken china and mosaic tiles could also be used.

Total paved area of site under parking, roads, paths or any other use should not exceed 25% of the site area.

Imperviousness of the site should not exceed the imperviousness factor as prescribed by the National Building Code of India, Bureau of Indian Standards, 2005; Part 9 (Plumbing services) section 5.5.11.2.1.

Total surface parking should not exceed the area as permissible under the local bylaw

Obtain minimum 50% of paved area on site to have pervious paving or shaded under vegetation or topped with finish having solar reflectance of 0.5 or higher.

## 1.5 Water conservation

Disruption of natural hydrology could be limited by reducing impervious cover, increasing on site infiltration and managing storm water run off. Following are some recommendation strategies:

1. Net imperviousness of the site should not exceed the imperviousness factor as prescribed by the National Building Code of India, Bureau of Indian Standards, 2005; Part 9 (Plumbing services) Section 5.5.11.2.1.
2. Implement vegetated roofs, pervious paving and other measures to minimise impervious surface on site. The



most effective method to minimise storm water run off volume is to reduce the amount of impervious area. By reducing impervious area, storm water infrastructure can be minimised or deleted from the project. (Source: LEED Reference Guide version 2.2).

3. Some of the strategies to mitigate impervious surfaces are:
  - Smaller building footprint.
  - Pervious paving
  - Underground parking, as pervious paving systems usually have a limit on transportation loads.
  - Green roofs
  - Bioswales/vegetated filter strips
  - Retention ponds
  - Clustering the development together to reduce the paved surface required for roads and sidewalks.
4. Implement a storm water management plan that prevents the post development peak discharge quantity from exceeding the pre-development peak discharge quantity.
5. Implement a storm water management plan that protects the drains and receiving channels from eroded soil.
6. Storm water run off outside the site could be significantly reduced by reuse storm water volumes generated for non-potable applications such as landscape irrigation, toilet and urinal flushing. Storm water capture and rain water harvesting guidelines are provided in section 2.8.
7. Reduction in the generation of storm water volumes would help maintain aquifer recharge cycle and in addition storm water volumes would not have to be conveyed to the receiving waters by the municipality, which reduces the load on municipality drainage system, and receiving waters are not impacted.
8. Best Management Practices employed to capture and or treat storm water run off.

## 1.6 Health and well being of construction workers

The objective is to ensure health and safety of the workers during construction, with effective provisions for the basic facilities of sanitation, drinking water, safety of equipments or machinery etc.

Following are the recommendations to be followed:

1. Comply with the safety procedures, norms and guidelines (as applicable) as outlined in the document Part 7 \_Constructional practices and safety, 2005, National Building code of India, Bureau of Indian Standards

2. Provide clean drinking water to all workers
3. Provide adequate number of decentralized latrines and urinals to construction workers.
4. Guarding all parts of dangerous machinery.
5. Precautions for working on machinery.
6. Maintaining hoists and lifts, lifting machines, chains, ropes, and other lifting tackles in good condition.
7. Durable and reusable formwork systems to replace timber formwork and ensure that formwork where used is properly maintained.
8. Ensuring that walking surfaces or boards at height are of sound construction and are provided with safety rails or belts.
9. Provide protective equipment; helmets etc.
10. Provide measures to prevent fires. Fire extinguishers and buckets of sand to be provided in the fire-prone area and elsewhere.
11. Provide sufficient and suitable light for working during nighttime.
12. Dangers, health hazards, and measures to protect workers from materials of construction, transportation, storage etc.
13. Safety policies of the construction firm/division/company.

### 1.7 Conclusive remarks

The aim and advantage of comprehensive and careful site assessment is to enable developers to optimize site's potential. Optimum use of identified natural climatic parameters existing on site could reduce the dependence of building on artificial forms of lighting, heating, cooling and ventilation and would also significantly contribute to the preservation of non-renewable resources. Appropriate and careful site analysis and site assessment would help in protection of ecologically sensitive areas and would reduce the damage of natural ecosystem on proposed site to the minimum.

### Reference

1. National building Code, 2005
2. Central Pollution Control Board standards
3. The Sustainable Design Handbook, China
4. TERI–Green Rating for Integrated Habitat Assessment
5. Soil plant water analysis : a methods manual, IARI, New Delhi
6. [www.moef.nic.in](http://www.moef.nic.in)
7. [http://envfor.nic.in/cpcb/aaq/aaq\\_std.htm](http://envfor.nic.in/cpcb/aaq/aaq_std.htm)
8. [www.epa.gov/npdes/pubs/chap03\\_conguide](http://www.epa.gov/npdes/pubs/chap03_conguide)

## CHAPTER 2 Water management

### 2.0 Introduction

In India, there is a growing demand on the existing water resources, which includes the river water sources, precipitation and ground water sources. Estimates reveal that by 2020, India's demand for water will exceed all sources of supply. It is projected that India would fall into the water-stressed category by 2025. Per capita water consumption in 1990 was 2,464 m<sup>3</sup> per capita per annum, but by 2025 with an expected population of 1.4 billion, it will almost certainly be in the stress category with less than 1,700 m<sup>3</sup> per capita per annum. The demand supply gap by 2050 shall be about 50 billion m<sup>3</sup> which translates into nearly 0.3 billion individuals foregoing water (assuming a per capita requirement of 150 L/ day). In addition to the huge gap in demand-supply, the distribution across various regions and zones of cities is highly varied.

### 2.1 Issues of concern

Water is the most important component for any society and is an important sustainable development indicator. The objective of any planned development should be to provide and ensure adequate, reliable and good quality potable water to its inhabitants. Water use in a residential building includes the demand for human consumption, cleaning, washing, flushing and gardening. The proportion of water use for various applications is shown in Figure 2. 1. For the commercial and institutional buildings, the additional demand include those for the utilities such as air conditioning, fire protection etc. It is important that any sustainable urban development project should integrate the sustainable and environment friendly water management plan at the design stage

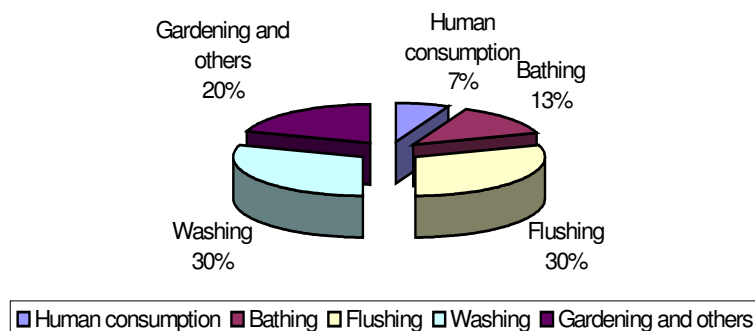

Figure 2.1: Water use in buildings

## 2.2 Scope of the section

Water management includes various aspects such as water conservation, wastewater treatment, rainwater harvesting, reuse and recycling of water etc. The objective of this section of the manual is to give guidelines to the developers and builders, on various aspects of water management. This section covers following issues:

1. Minimizing the demand of water required within building, landscape, process (air-conditioning etc) and construction.
2. Techniques, best practices and standards for recycling of wastewater
3. Minimize the load on the municipal supply and groundwater sources through recycling of water
4. Techniques for rainwater harvesting including estimation of the potential of rainwater harvesting for different region.
5. Measures for quality control of various water source such as fresh water, underground water, municipal, tankers, rainwater and recycled water.

## 2.3 Mitigation technology options

### 2.3.1 Water conservation within buildings

Minimizing the water demand within buildings is the first and foremost step in water management. Water conservation helps to ensure that this important resource will be available for many generations to come. Conserving water also indirectly saves energy, which is needed to process, treat, transport and in cases of areas having cold climate to heat water. Hence to have the maximum savings, optimal and economical use of water through water conservation should be the priority of the new constructions. In addition to technical measures such as use of water efficient domestic appliances, there is a need to create awareness and to educate people to address water leakage problems through proper maintenance of fixtures.

#### *2.3.1.1 Water usage within buildings.*

In India, the average domestic water consumption is 4.1% of the total water use. As per the Bureau of Indian Standards, the per capita water requirement varies with building type.

As per BIS, for residential buildings with a population of 20,000-1,00,000, the per capita consumption is 100-150 lpcd and for those with population above 1,00,000, the consumption is 150-200 lpcd. Out of the 150 to 200 litres per head per day, 45 litres per head per day may be taken for flushing requirements and the remaining quantity for other domestic purposes.

For the other types of buildings, the water requirement varies between 30 to 340 LPCD. The details of the water demand of other buildings is given in Table 2.1.

Table 2.1: Water requirements for different types of buildings

Sl. No	Type of Buildng	Consumption (litres/day)
i)	Factories with bath rooms	45 per head
ii)	Factories without bath rooms	30 per head
iii)	Hospital (including laundry):	
	a) Number of beds not exceeding 100	340 per head
	b) Number of beds exceeding 100	450 per head
iv)	Nurses' homes and medical quarters	135 per head
v)	Hostels	135 per head
vi)	Hotel (up to 4 star)	180 per head
vii)	Hotel (5 star and above)	320 per head
viii)	Offices	45 per head
ix)	Restaurants	70 per seat
x)	Cinemas, concert halls and theaters	15 per seat
xi)	Schools	
	a) Day schools	45 per head
	b) Boarding schools	135 per head

In addition, water demand of visitors to these building is considered as 15 LPCD

Source: National Building Code, 2005

#### 2.3.1.2 Quantification of water demand in buildings

For every new development/construction, the initial step should be to assess the impact of the development on the available water resource. The amount of water demand can be calculated based on the occupancy of the building and the per capita consumption as given by BIS for different categories.

Total quantity of water used= Occupancy x Quantity (LPCD)

#### 2.3.1.3 Water saving practices and their potential

Water usage for applications such as flushing, bathing and washing is as high as 93% of water demand in any building. However, measures can be adopted to reduce this demand through use of water efficient practices and devices (efficient plumbing fixtures). These would result in significant saving of water and contribute towards protection of the environment. Some of the common practices and devices that can save water are covered below:

1. Monitoring water use: Use of water meter conforming to ISO standards should be installed at the inlet point of water uptake and at the discharge point to monitor the daily water consumption. This would also enable the user to identify if there are any points of leakages.
2. Use of water saving devices/ fixtures: About 40% of all water used indoors is in the bathroom and toilets and more than 10% of that used is in the kitchen. The

conventional fixtures used in toilets use water at the rate of 12-15 litres per flush. In normal scenario, the taps and showerheads in buildings consume water at the rate of 20 litres of water per minute. The flow rates of these fixtures depend on the pressure at which these are operated. However there exists the opportunity to lower the consumption through the use of following efficient fixtures:

- **Low flow flushing systems:** Water consumption is more for flushing applications in any building. Use of more efficient water saving toilets having dual flush system can result in a saving of atleast 50% of water. Dual flush systems can be installed in order to allow different volume of water for flushing liquids and solids. To facilitate efficient cleaning at low volume, it is possible to install suitable water closets.
- **Sensor based fixtures:** Sensors based fixtures functions only in the presence of user. Various types of sensor based technologies are magic eye sensor for urinals, solenoid self-operating valves etc. Infrared and ultrasonic sensors discharge a set amount of water only when the taps are being used thus resulting in water saving as compared to manually operated valves. In addition to its advantage in reducing water consumption, sensor-operated taps also result in better hygiene particularly in a public place.
- **Urinals:** By using automated flushing urinals usage of water is very high. By replacing these with sensor-based urinals such as magic eye sensor, the water use is reduced to 0.4 litres per flush. In place of conventional urinals, if the low flow urinals are used, water saving amounts to 3 litres per flush.
- **Waterless urinals:** Waterless urinals are an efficient technique to save water. The system works without any water but with the use of biodegradable liquid in the cartridge fitted at the bottom of the urinal. Each cartridge is adequate for 7000 uses.
- **Water taps:** A normal tap works at a flow rate as high as 20 lpm. Use of low flow faucets along with other water saving devices such as auto control valves, pressure reducing devices, aerators and pressure inhibitors for constant flow, magic eye solenoid valve, self operating valves can result in 25 – 50% of water savings.
- **Showerheads:** In a conventional shower, water is delivered at the rate of 20 litres of water per minute at a pressure of 60 psi. A significant reduction in water consumption is possible through use of low flow shower which results in a flow of 7.5 lpm at design pressure of 80 psi. Flow restrictors and temporary cut-off valves can further save water. In addition to the use of low water

consuming fixtures, it is also possible to introduce other features such as aerators, use of spray nozzles, automatic shut-off nozzles and pressure reducing valves along with these fixtures.

- Tap aerators: Tap aerators can be effective by facilitating cleaning through increasing the pressure at which the water is delivered even at low flow rates. Installation of flow regulators can be done where the aerators cannot be installed.
- Auto control valves: Automatic shut-off valves can be used to control the flow of water for a preset time limit and with use, which is linked to the release of the lever or handle.
- Pressure reducing device: The reducers can be used to control the pressure in the water line, which will affect the discharge rate and also to maintain uniform flow at different levels. A pressure reduction device can be installed when the pressure in the line exceeds 50-60 psi. It is observed that a reduction of pressure from 80 to 65 and 50 psi can result in a reduction of water flow of 10% and 25%, respectively.

#### *2.3.1.4 Other appliances*

##### *Water efficient washing machines*

One of the most effective water saving mechanisms in clothes washers is a horizontal- axis tub or drum. These kind of machines can clean as many clothes as comparable vertical axis or 'agitator washers', but with less water. Manufacturers estimates of water saving obtainable with horizontal axis washing machines range from one-third to one-half the water and energy used by conventional, vertical axis machines. These types of machines can be used in big hotels etc.

#### *2.3.1.5 Dual pipe plumbing*

Introduction of dual pipe in the buildings for use of water with different water quality namely ground water with high hardness, municipal supply water, treated soft water and recycled water can result in optimal use of water for different applications thus saving on the high quality water. Installation of dual pipe plumbing for using recycled water / rain water can save the potable water from municipal supply or ground water. There can be two lines, one supplying fresh water for drinking, cooking and bathing etc and other for supply of recycled water for flushing, landscape irrigation, car washing, thermal conditioning etc. This results in saving of more than one-third of fresh water demand and life of existing sewerage can be improved and also promotes decentralized treatment system. This system needs space for establishment and initial investment and retrofitting.

### 2.3.2 Water quality

In addition to providing adequate water supply for building occupants, quality of water is also a key concern. Bureau of Indian Standards has recommended a set of parameters, which should be complied with. These are given in Table 2.2.

Table 2.2 Standards for drinking water

Parameter	Drinking water
Total hardness (as CaCO <sub>3</sub> ) (mg/litre)	300
Total dissolved solids (mg/litre)	500
Chlorides as chlorine (mg/litre)	250
Colour (hazen)	5
Turbidity (NTU)	5
Alkalinity (mg/l)	200
Calcium (as Ca), mg/l	75
Boron (mg/litre)	1
Sulphates (as SO <sub>4</sub> )(mg/litre)	200
Nitrates (as NO <sub>3</sub> ) (mg/litre)	45
Conductivity at 25° C (us/cm)	-
PH	6.5 – 8.5
Anionic detergents as MBAS (mg/l)	0.2
Arsenic (mg/litre)	0.05
Iron (mg/litre)	0.3
Fluorides (mg/litre)	1
Lead (mg/litre)	0.05
Copper (mg/litre)	0.05
Zinc (mg/litre)	5
Phenolic compounds (as C <sub>6</sub> H <sub>5</sub> OH) (mg/l)	0.001
Cyanide (mg/l)	0.05
Chromium (mg/l)	0.05

Source: IS: 10500:1991

Further as per the CPCB, water quality standards for different classes of inland waters have been given for different applications which should be followed. (Table 2.3)

Table 2.3 Water quality standards for freshwater classification

Characteristic	Designated use class of inland waters				
	A	B	C	D	E
Dissolved oxygen (mg/l), minimum	6	5	4	4	-
pH	6.5-8.5	6.5-8.5	6.5-8.5	6.5-8.5	6.5-8.5
Biochemical oxygen demand (5 days at 20°C), mg/l	2	3	3	-	-
Total coliform organisms, MPN/100 max.	50	500	5000	-	-
Colour Hazen units	10	300	300	-	-
Chlorides (as Cl), mg/l, maximum	250	-	600	-	600
Sodium absorption ratio, max	-	-	-	-	600
Boron(as B), mg/l Max					2
Sulphates (as SO <sub>4</sub> ), mg/l	400		400		1000
Nitrates (as NO), mg/l max	20		50		-



Characteristic	Designated use class of inland waters				
	A	B	C	D	E
Free ammonia (as NH <sub>3</sub> ), mg/l				1.2	-
Conductivity at 25°C microhm/cm max.				1000	2250
Arsenic (as AS), mg/l max.	0.05	0.2	0.2		-
Iron (as Fe), mg/l	0.3		50		-
Fluorides (as F), mg/l	1.5	1.5	1.5		-
Lead (as Pb), mg/l Max	0.1		0.1		
Copper (as Cu), mg/l	1.5		1.5		
Zinc (mg/l), max	1.5		1.5		
Manganese (as Mn), mg/l	0.5				
Total dissolved solids (mg/l)	500		1500		2100
Total Hardness (as CaCO <sub>3</sub> ), mg/l	300				
Magnesium (as Mg), mg/l	100				
Chlorides (as Cl), mg/l	250	600			600
Cyanides (as CN), mg/l	0.05	0.05	0.05		

- A- Drinking water sources without conventional treatment but after disinfecting  
B- Outdoor Bathing (Organised)  
C- Drinking water source with conventional treatment followed by disinfecting  
D- Propagation of wildlife, fisheries  
E- Irrigation, industrial cooling

### 2.3.3 Water use reduction

To estimate the reduction in water use achieved by the building by following the mitigation measures, use following steps:

Step 1: Estimate total water demand based on the occupancy and type of building

Step 2: List various efficient fixtures and other measures

Step 3: Calculate demand reduction as compared to the BIS per capita water consumption

Under normal conditions, water consumption per person for flushing is 45 litres (9 litre/flush with 5 number of uses).

With efficient fixture (3 and 6 litre/flush), water use is 21 litre (3 litre/flush with 3 uses and 6 litre /flush with 2 uses).

Water use per person for washing with normal fixture with a flow rate of 20 litres per minute is 40 litre (assuming use for 2 minutes), while with efficient fixture (flow rate of 7.5 lpm) is 15 litres.

Table 2.4 : Estimation of water use reduction

Category	Consumption (lpcd)	Reduced Consumption (lpcd)	Reduction (%)
Human consumption	7	7	
Bathing	20	20	
Flushing	45	21	53%
Washing	40	15	62%
Miscellaneous	23	23	
Total	135	86	36%

### 2.3.4 Water conservation in landscape

Landscape forms an important part of the building environment. This is constituted by combination of vegetation, paving and various other landscape features such as water bodies. The vegetation includes lawns, shrubs, herbs and trees. In general, the water demand for lawns and shrubs are higher as compared to trees, which does not require or require less water after establishment. In addition, native species also require less water.

#### 2.3.4.1 Estimation of water demand for landscape

The water requirement of the landscape can be estimated using the following equation:

$$\text{Water requirement (lpd)} = \text{Canopy area (sq.m)} \times \text{Evapotranspiration rate (mpd)} \times \text{plant factor} \times \frac{1000}{\text{irrigation efficiency}}$$

1. Monthly Evapotranspiration rate (ET<sub>o</sub>): The potential evapotranspiration rate (PET) is the climate factor, refers to the amount of water required by the plant for healthy growth (depending on the climate). Evapotranspiration rate determines the rate at which plants lose water through evaporation. It is affected by humidity and temperature at a given time. These rates vary with the season and are different for different months. The data is available with the Indian Meteorological Department for different stations. The data can be procured from Additional Director General of Meteorology (Research), Shivajinagar, Pune – 411 005.
2. Canopy area is the area covered by shrubs, grass covers, and for trees it is the plan view and is assumed as 25 sq. m per tree.
3. The plant factors are categorized as
  - 1 for evergreen fruit trees, small shrubs, lush ground covers
  - 0.7 for Newly planted native plants in semiarid and arid regions; ornamental or shade trees and shrubs native to more humid areas
  - 0.4 for plants native to the areas

#### 2.3.4.2 Measures for reducing water demand for landscape

The water consumption for the gardening depends on the type of plant species and the plant factors. As the plant factor for native species and trees is the minimum, one of the options to reduce the water demand for gardening is to include more native species and low water consuming species. Other options include use of efficient fixtures for watering, following certain best practices to minimise losses and optimise consumption.

1. Xeriscaping: Xeriscape is one of the efficient ways to reduce water consumption through creative landscaping. This involves plantation of dry plants and those plants, which can

live, once established, with little or no supplemental watering. Some of these are also drought tolerant and can survive even in areas with minimal rainfall. Annexure 1 gives the list of trees which requires minimum rainfall and can survive without water after establishment. Some of the palm trees such as Phoenix dactylifera, Yucca starlite and groundcovers such as Asparagus sprengeri, which is succulent, can be used as part of the landscape to conserve water. Other species namely, Pandanus Dwarf, which is xerophytic, and Bougainvillea which is a climber would also help in water use minimization.

2. Native vegetation : Native vegetation is original to a particular place, including trees, shrubs, and other plants. These generally require less water and less maintenance. In Annexure 2, list of species for various agro climatic regions are given .
3. Efficient irrigation equipments
  - Drip irrigation : To save water, drip irrigation is an efficient technique as it prevents loss of water due to evaporation, run – off and percolation. Further, it has a better control and facilitates uniform water distribution. However, this system cannot be used for lawns and ground covers but for non –native turf and other non-xerophytic plants.
  - Sprinkler irrigation : Sprinkler irrigation system requires a network of pipes and pumping system to maintain sufficient pressure for uniform distribution. It is best suited for areas with sandy soils which have high infiltration rates. To prevent water logging, the system should be designed in such a way that infiltration rate exceeds the application rate. Sprinklers which can produce fine sprays are more efficient as compared to those that produce large water droplets.

The efficiencies of irrigation systems differ widely. Further, to improve the efficiency certain measures can be followed, which includes use of a pressure regulator for pressures greater than 30 psi which will significantly reduce the loss during watering. Efficiencies of different kinds of irrigation equipment are given in table 2.5 below

Table 2.5 Efficiency of irrigation equipment

Irrigation system	Efficiency
Micro, drip	85%
Micro, spray	80%
Multiple sprinkler	75%
Sprinkler, container nursery	20%
Sprinkler, large guns	70%
Seepage	50%
Crown flood	50%

Source : TERIGRIHA

### *Efficient central systems*

An auto irrigation system with programmed time schedule can be installed for optimal use of water. To avoid over watering particularly during the rainy season, a rain shut-off device and soil moisture sensor should be used. It is also advisable to group the plants based on their water needs to minimize water loss.

4. Fixed time schedule for watering : Time schedule for watering of plants plays an important role in saving water. Irrigation should be done during the coolest time of the day (early mornings and evenings) to avoid loss due to evaporation and wind drift. Also, the frequency of irrigation should be reduced during the winters. Regular flushing of the irrigation lines and other parts should be done. The use of combination of mitigation options can result in savings of water as indicated in Table 2.6 below. The table indicates the reduction in water that is possible by stepwise reduction in areas of high water consuming species. By reducing the lawn area by 50% and replacing it with shrubs, it is possible to achieve 32 % savings and by further introducing native species to the level of 25%, further increase in savings of 42% is achieved.

Table 2.6: Estimate of savings in water

Options	Savings in water (%)
100% Lawn	
50% lawn: 50% shrubs	32
50%lawn: 25%shrubs: 25%native	42
100% native	64

### 2.3.5 Water quality standards for irrigation

The BIS standards for irrigation is indicated in Table 2.7. It is important to conform to the prescribed standards while using water from various sources such as ground water, municipal water, rain water or treated water.

Table 2.7: Standards for irrigation

Parameter	Irrigation
Total dissolved solids (mg/litre)	2100
Chlorides as chlorine (mg/litre)	500
Boron (mg/litre)	2
Sulphates (as SO <sub>4</sub> )(mg/litre)	1000
Conductivity at 25° C (us/cm)	2.25
pH	6.0 – 8.0

## 2.4 Water conservation in process (air-conditioning)

In industrial as well as commercial applications, cooling towers are the largest consumer of potable water. Though there is continuous re circulation of water in cooling towers, still there is major loss associated with evaporation and drift losses. However, proper operations and maintenance of cooling towers can lead to significant savings in water consumption.

### 2.4.1 Estimation of water demand

Water consumption in air conditioning :

$$W = 12 \times t \times C, \text{ where}$$

W = annual water consumption

t = Hours of operation { 2500 h per annum}

C = Capacity of plant (in TR)

Water consumption in evaporative cooling :

In Single stage system

$$W = R \times q \times \frac{1}{1000}, \text{ where}$$

W = annual water consumption

R = water consumption rate (12 litre/hr)

q = air quantity (in CFM)

In Double stage

$$W = R \times q \times \frac{1}{1000}, \text{ where}$$

W = annual water consumption

R = water consumption rate (16 litre/hr)

q = air quantity (in CFM)

### 2.4.2 Mitigation options

#### 2.4.2.1 Measures for reducing water demand in evaporative cooling process

In the conventional cooling system, water consumption is quite high. Hence, alternative systems such as evaporative cooling unit, which can result in, water saving upto 40% can be used to replace the conventional system.

Evaporative cooling unit produces effective cooling by combining the natural process of water evaporation with air. It uses right combination of controlled air flow passage across adequately designed wet surface to provide optimum efficiency.

Adopting a two stage system where the air is precooled indirectly by circulating water in the first stage and the pre cooled air is further cooled by water through direct contact in place of single stage system would result in 20% savings of water. It can be observed that although the water consumption rate is higher for 2 stage, there is a net reduction in water requirement due to the overall reduction in air quantity

### 2.4.3 Water quality standards for air- conditioning

Water with hardness less than 50 ppm of CaCO<sub>3</sub> is recommended for air-conditioning applications. Untreated water if used in air – conditioning system can lead to scale formation, corrosion and organic growth. Hence, it is essential to analyse the supply source for various constituents including dissolved solids.

Hardness in water is represented by calcium and magnesium salts, which may also include aluminium, iron, manganese, zinc etc. Temporary hardness is attributed to carbonates and bi-carbonates of calcium and / or magnesium expressed in parts per million (ppm) as CaCO<sub>3</sub>. The permanent hardness is due to sulphates, chloride, nitrites of calcium and / or magnesium expressed in ppm as CaCO<sub>3</sub>.

Temporary hardness is primarily responsible for scale formation, which results in poor heat transfer resulting in increased cost of energy for refrigeration and air conditioning. Permanent hardness (non-carbonate) is not a critical factor in water conditioning due to its solubility. In many cases, water may contain as much as 1 200 ppm of non-carbonate hardness and not deposit a calcium sulphate scale.

A chemical analysis of water sample should provide number of total dissolved solids (TDS) in parts per million (ppm) as also composition of each of the salts in parts per million. Also, water with pH less than 5 is quite acidic and corrosive to ordinary metals and needs to be treated.

(Source: National Building Code 2005)

## 2.5 Water use during construction

### 2.5.1 Parameters for water quality

Water used shall be clean and reasonably free from injurious quantities of deleterious materials such as oils, acids, alkalis, salts and microbial growth. Generally, potable water shall be used. Where water can be shown to contain any sugar or an excess of acid, alkali or salt, that water should not be used. As a guide, the following concentrations may be taken to represent the maximum permissible limits of deleterious materials in water.

1. Limits of acidity: To neutralize 200 ml sample of water, it should not require more than 2 ml of 0.1 N caustic soda solution.
2. Limits of Alkalinities: To neutralize 200 ml sample of water it should not require more than 0.1 ml of 0.1 N hydrochloric acid.
3. Percentage of solids should not exceed:  
Organic . . . . . 200 ppm (0.02%)  
Inorganic . . . . . 3000 ppm (0.30%)  
Sulphates . . . . . 500 ppm (0.05%)  
Alkali chlorides. . . . . 1000 ppm (0.1%)

During the construction process, it is necessary to use pure drinking water to prepare lightweight concrete. (Refer table 2.2, standards for drinking water). In the absence of pure water, the sea water may be used with hydraulic lime and cement. It helps in preventing too quick drying of the mortar. However, it is not advisable to use sea water in making pure lime mortar or surkhi mortar because it will lead to efflorescence.

Source : CPWD manual

### 2.5.2 Measures for reducing water demand during construction

To avoid wastage of curing water, following guidelines are to be followed:

1. Curing water should be sprayed on concrete structures; free flow of water should not be allowed for curing.
2. After liberal curing on the first day, all concrete structures should be painted with curing chemical to save water. This will stop daily water curing hence save water.
3. Concrete structures should be covered with thick cloth/gunny bags and then water should be sprayed on them. This would avoid water rebound and will ensure sustained and complete curing.
4. Ponds should be made using cement and sand mortar to avoid water flowing away from the flat surface while curing.
5. Water ponding should be done on all sunken slabs, this would also highlight the importance of having an impervious formwork.

Source: TERI GRIHA

## 2.6 Waste water generation

### 2.6.1 Introduction

Every building generates wastewater amounting to almost 80% of total water consumed. The major source of wastewater includes the grey water from kitchens, bathrooms and black water from toilets. To maintain the surrounding environment and to reduce the demand on potable water by providing secondary and tertiary treated water, it is important for every new construction to ensure treatment of the wastewater generated from the building through centralized or decentralized systems.

### 2.6.2 Issues of concern

There is lack of proper drainage systems in case of new developments in certain cities. In some of the cities, the existing sewerage and the centralized sewerage treatment plant is not adequate to cater to the additional load of the new development.

### 2.6.3 Estimation of waste water generated

Waste water generated = 80% of water used (For water demand, refer to table 2.1)

## 2.6.4 Mitigation options

### 2.6.4.1 Measures for reducing waste water generation

Waste water generated can be reduced through water use reduction by using efficient plumbing fixtures. {Refer section 2.3.1.3 to see the description for efficient plumbing fixtures.}

### 2.6.4.2 Treatment techniques

Waste water which includes both black water from toilets and grey water from bathrooms and kitchens, washings can be suitably treated and reused for non potable applications such as irrigation, flushing etc. Different treatment techniques can be adopted depending on the land availability, quantity and characteristics of the wastewater. Treatment plants normally used for building sewage are based on biological processes. In addition, artificial wetlands or reed bed systems for waste water treatment based on the use of deep – rooted plants can also be used at decentralized level.

1. Aerobic treatment systems: These processes are based on the biological conversion of organic contaminants in the wastewater in the presence of oxygen; carbon dioxide is given off and sludge produced leaving the water relatively clean. The wastewater is generally pretreated by passing it through a settling chamber before aeration; the system could be based on either suspended growth or attached growth.

#### Advantages:

- Complete treatment of the wastewater
- Used as the final polishing step before discharge of wastewater

#### Disadvantages:

- High Land requirement
- High Energy required for operation of the treatment plant





**Figure 2.2 : Aerobic design**

2. Anaerobic treatment systems: These systems are also based on the degradation of pollutants in the wastewater by microorganisms but reactions occur in the absence of oxygen. Conventional digesters such as sludge and anaerobic CSTR (continuous stirred tank reactors) have been used in India for many decades in sewage treatment plants for stabilizing activated sludge and sewage solids. Presently, high rate biomethanation systems based on the concept of sludge immobilization techniques (UASB, fixed films, etc.) is also being considered. In the case of upflow anaerobic sludge blanket (UASB) reactors, the treatment efficiencies are high even for a very short retention time. This is being used for treatment of domestic wastewater for small towns. An advantage with this type of reactor is the generation of useful by products – high calorific value fuel biogas and digested sludge that can be used as manure.

#### Advantages

- Lower energy requirement combined with the production of biogas
- Low nutrient requirement
- High degree of waste stabilization
- Handling high organic loading rates
- Lower production of excess sludge, which in addition, is well-stabilized and therefore easier to dispose.
- Easier preservation of well-adapted sludge which can be kept unfed for a period of more than one year without any deterioration.

#### Disadvantages

- Requires skilled operation
- Capital cost is high

3. Root zone treatment system: The system is suitable for the treatment of wastewater from various sources containing biodegradable compounds. The process was developed in 1970 by Dr Reinhold Kickuth of Germany. The system is most suited to decentralized wastewater treatment in small colonies, hotels, etc. It is based on the principle of attached growth biological reactors similar to conventional trickling filters with a combination of aerobic and anaerobic zones. The contaminants present in the wastewater are treated as they seep through the root-zone of the plants by a combination of plants, soil, bacteria and hydraulic flow systems resulting in physical, chemical, and microbiological processes. Oxygen present in the zones facilitates the degradation of wastewater. A wide variety of micro organisms present in the root-zone of the plants result in efficient removal. There is efficient reduction of pathogens also by percolation through the bed material.

#### Advantages

- Low capital costs
- Low operating and maintenance costs
- No chemicals required for the treatment process
- Absence of byproducts requiring treatment
- Technical expertise for the operation not required
- Effective treatment resulting in tertiary standards

#### Disadvantages:

- High land requirement

#### 2.6.2.4 *DEWATS*

DEWATS stands for “Decentralized Wastewater Treatment Systems”. DEWATS system consists of four basic technical treatment modules, namely,

1. Primary treatment: sedimentation and floatation
2. Secondary anaerobic treatment in fixed-bed reactors: baffled upstream reactors or anaerobic filters
3. Tertiary aerobic treatment in sub-surface flow filters
4. Tertiary aerobic treatment in polishing ponds

#### Advantages

1. Low maintenance without technical energy inputs
2. Affordable prices due to locally available materials
3. Flexible treatment capacity ranging between 1- 1000 m<sup>3</sup> per day.
4. Reliable, long lasting and tolerant towards inflow fluctuation.

DEWATS applications are designed and dimensioned in such a way that treated water meets requirements stipulated in environmental laws and regulations.

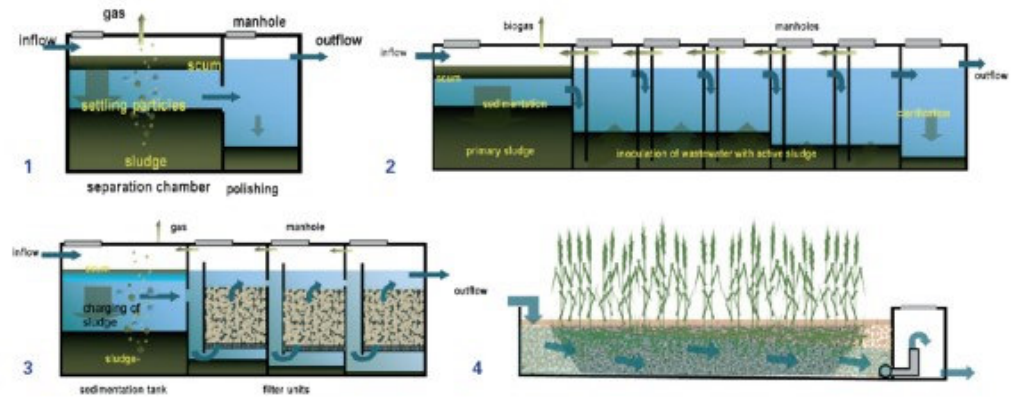

**Figure 2.3 Dewats modules for wastewater treatment:**

1. Settler 2. Anaerobic Baffled Reactor 3. Anaerobic Filter 4. Planted Gravel Filter

Source: BORDA-net.org

#### 2.6.2.5 Soil Biotechnology (SBT)

Soil Biotechnology (SBT) process for organic waste (solid and liquid) processing developed at Chemical Engineering Department IIT Bombay has the necessary features of green technology that are cost effective, energy efficient and is available to the users at the scales required. The intellectual property rights of the technology are covered under Indian and US Patent.

The science, technology and performance features of SBT are outlined below.

#### Process Description & Design :

A typical SBT plant consists of impermeable floor (PCC or HDPE membrane depending upon the terrain) & containment with suitable water proofing (UCR/RCC walls), raw water tank, filtered water tanks, bioreactor containing suitable media, culture and bio indicator plants required for the wastewater renovation.

The bioreactor is constructed over the impervious floor. It consists of soil bays containing media, which is cultured and planted with select bio-indicators. Plant operation is set to achieve the required level of purification. Plant operation involves pumping the raw water into the soil bays, sprinkling specified additives and maintaining the bio-indicators and all functions as prescribed and demonstrated during training. The renovated water is to be pumped via suitable distribution system for gardening.

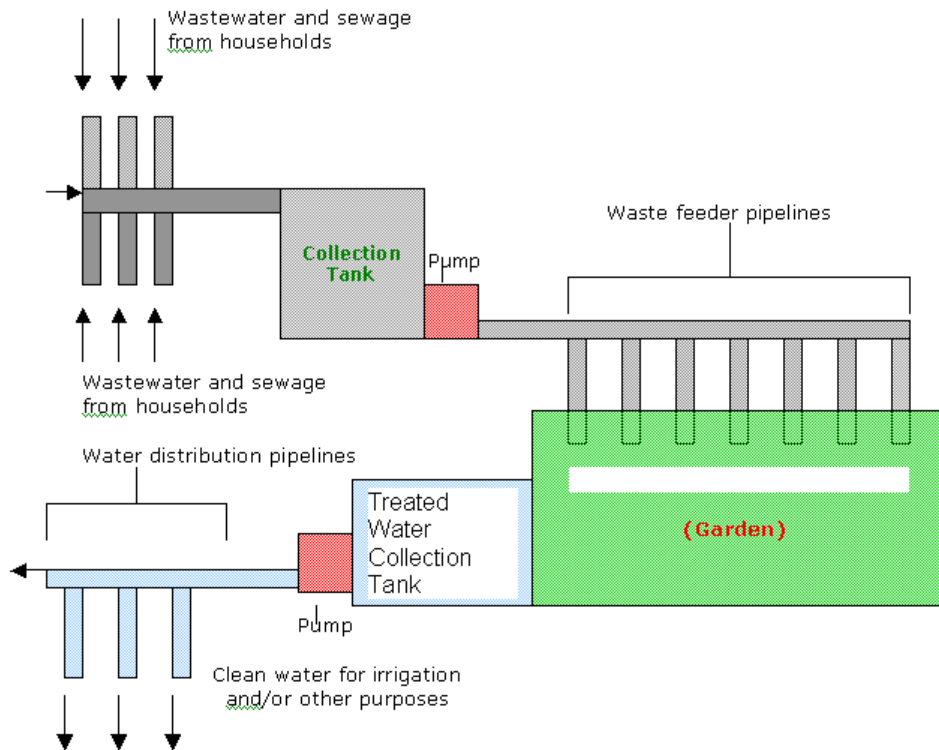

**Figure 2.4 Flow Diagram for Liquid Waste (Sewage/Effluent) treatment by SBT**

#### 2.6.2.6 INDION Membrane Bio - Reactor

INDION Membrane Bio – Reactor is among the latest technologies in bio-chemical treatment. It is designed to produce high quality treated water from wastewater with highest possible contaminant reduction without using any chemicals.

The characteristics of the INDION MBR process is the use of revolutionary submerged micro and ultra filtration membranes in the biological process water tank, to produce high quality permeate from domestic sewage, primary and secondary wastewater, cooling tower blow down etc. The submerged membranes used in the biological process water tank totally removes suspended sludge from the activated sludge liquid and long term stable MBR operation is achieved with high permeate flow rates.

MBR can be applied in housing complexes, townships, hotels, golf and country clubs, industrial estates and existing plant upgradation.

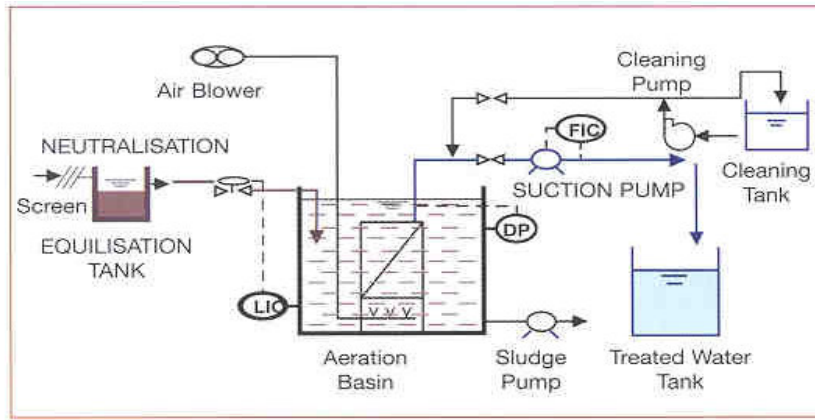

**Figure 2.5: Typical treatment scheme**

Advantages

1. Low energy consumption (0.30 kwh/m<sup>3</sup>) for filtration.
2. Upto 99.999% removal of total coliform
3. Compact, requires 1/2 to 1/3 space over a conventional system.
4. Modular in construction and design

*2. 6.2.7 INDION Package sewerage treatment plant*

It is unique combination of lamella plate clarification and results in a ready to operate, prefabricated solution of outstanding performance and efficiency.

*Treatment process*

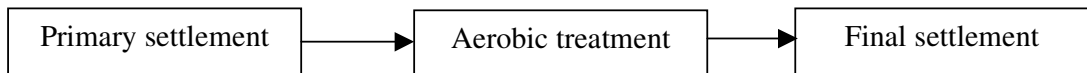

*Primary settlement:* Sewage initially enters the primary settlement tank. The tank incorporates lamella parallel plates, which aid in reducing the suspended solids by 75% and the BOD by 25%. This zone is relatively maintenance free and contains no moving mechanical or electrical devices.

*Aerobic treatment:* The effluent then enters the aerator bio-zone, which is a combined fixed film reactor, and active aeration system is mounted on a horizontal shaft. The aerator provides a solid surface area for microorganisms to attach themselves; these then feed on the organic matter present in the effluent. The rotation of the drum creates an aeration of the liquid. The bio-zone is self-cleansing and does not require extraneous pumping or sludge return.

*Final Settlement:* The treated effluent then moves to a settlement area. This area contains a lamella parallel plate

assembly for settling finer particles. The submersible pump removes sludge to a sludge storage compartment on a regular time basis.



**Figure 2.6 : Packaged Treatment Plant**

#### 2.6..2.8 Akar Wastewater treatment plants

AKAR range of ADBR (Akar Dynamic Bio-Reactor System) is a dynamic bio-reactor waste water treatment packaged plants of different capacities from 10 KLD to 1000 KLD. ADBR systems works fast that the process reaction time reduces by more than 35%. This helps in saving space by more than 35% and saving in energy consumption by almost 35%.

#### Advantages:

1. No time is needed in erecting and commissioning the system and this system is ready to use.
2. These systems are mounted on skids therefore easily transportable and are compact. Hence it requires no excavation, no major concrete work, no major onsite fabrication and pipe / fittings.

#### 2.6.3 Standards for disposal of waste water

Maximum permissible limits (mg/litre) for effluent discharges are given in Table 2.8.

Table 2. 8 Permissible limits for effluent disposal

Parameter	Into inland surface waters Indian Standards: 2490 (1974)	Into public sewers Indian Standards: 3306 (1974)	On land for irrigation Indian Standards: 3307 (1974)
pH	5.5-9.0	5.5-9.0	5.5-9.0
Biological oxygen demand (for five days at 20°C)	30	350	100
Chemical oxygen demand	250	-	-

Parameter	Into inland surface waters Indian Standards: 2490 (1974)	Into public sewers Indian Standards: 3306 (1974)	On land for irrigation Indian Standards: 3307 (1974)
Suspended solids	100	600	200
Total dissolved solids (inorganic)	2100	2100	2100
Temperature (°C)	40	45	-
Oil and grease	10	20	10
Phenolic compounds	1	5	-
Cyanides	0.2	2	0.2
Sulphides	2	-	-
Fluorides	2	15	-
Total residual chlorine	1	-	-
Pesticides	-	-	-
Arsenic	0.2	0.2	0.2
Cadmium	2	1	-
Chromium (hexavalent)	0.1	2.0	-
Copper	3	3	-
Lead	0.1	1.0	-
Mercury	0.01	0.01	-
Nickel	3	3	-
Selenium	0.05	0.05	-
Zinc	5	15	-
Chlorides	1000	1000	600
Boron	2	2	2
Sulphates	1000	1000	1000
Sodium (9%)	-	60	60
Amoniacal nitrogen	50	50	-
Radioactive materials	10 <sup>-7</sup>	10 <sup>-7</sup>	10 <sup>-8</sup>
Alpha emitters (milli curie/millitre)	10 <sup>-6</sup>	10 <sup>-6</sup>	10 <sup>-7</sup>
Beta emitters (micro curie/millitre)			

Source : CPCB, 1998, Pollution Control Acts, Rules, and Notifications issued thereunder. Volume I, pp. 311-312. New Delhi: Central Pollution Control Board, MoEF. 501 pp.

## 2.7 Construction wastewater management

Wastewater generated from the site during the construction contains suspended materials, spillage and washings from the various areas which can be hazardous and should not be mixed with the sewage water or allowed to percolate into the ground. A separate drainage should be provided for the construction wastewater and collected in a separate basin. The water should be discharged into the sewage drain after pre treatment including filtration and removal of contaminants to the standards prescribed for disposal.

## 2.8 Sanitation facilities for construction workers

Sewage generated from the areas occupied by the construction labourers have to be directed into the existing sewage drain of the area. In case of non availability of the sewer system, an onsite decentralized treatment system has to be provided.

## 2.9 Rain water harvesting

### 2.9.1 Introduction

With burgeoning population and rising demands the pressure on the existing water resources has grown many folds. Large-scale construction and urban development projects catering to the need of growing urbanization lead to land use modification increasing exploitation of scarce water resources and subsequent increase in generation of waste water discharges and surface runoff. Rainwater harvesting is the age-old concept, which holds immense potential in the current times in controlling runoff and resulting water logging problems besides assuring an alternative source of water and a supplement to existing natural resources in a wide variety of circumstances.

### 2.9.2 Issues of concern

Despite having some clear advantages over other sources, rainwater use has frequently been rejected on the grounds of its limited capacity or due to water quality concerns. This is unfortunate as in many cases some simple upgrading and the integrated use of rainwater collection with other technologies is all that is required to obtain a cost effective and reliable water supply solution. (Gould, 1999)

Predictions regarding global warming could have a major effect in significantly increasing water demand in many cities. Increased climatic variability and the greater frequencies of droughts and floods possible in many areas will also make the role of rainwater harvesting systems even more important as sources of supplementary, back-up, or emergency water supply. This will particularly be the case in areas where increasing pressure is put on existing water resources. (Gould, 1999)

At the same time, while rainwater harvesting can be done in almost all environment and conditions, it is important that the concept is not followed blindly but based on site-specific scientific assessment. The amount of rainfall available varies from region to region. There are several methods by which rainwater can be stored, used and conserved. Each system depends on the amount of precipitation, the period in which the rainfall occurs in a year and the physical infrastructure, for example the space available to store the water, etc. Two major systems that are ideal for urban and semi-urban developed areas are artificial ground water recharge, and roof top rainwater harvesting (NBC, 2005).



The parameters to be considered for determining the feasibility and design of an appropriate rainwater harvesting system have been discussed in detail in the following sections.

### 2.9.3 Measures to be taken

#### 2.9.3.1 *At the planning stage*

While planning for rainwater harvesting, site specific assessment needs to be undertaken to ensure the techno- social and economic feasibility of rainwater harvesting system. This is necessary both for the type of structures planned and the proposed use of the harvested rainwater. The need for rainwater harvesting in an area may be broadly determined by:

1. The existing regulations and notifications (such as building byelaws) to check whether rainwater harvesting is mandatory for the area.
2. This must be further analysed in the light of site specific needs as well, such as
  - Available sources and their sustainability both in terms of surface water and ground water sources.
  - Existing or perceived water logging problem due to low lying area and related issue of water borne diseases.
  - Depleting/over-exploited groundwater aquifer or areas having high rate of decline of groundwater table
  - Poor quality groundwater/threat from salt intrusion in case of coastal/island states
  - Problems of accessibility in hilly terrains. Even in case of sufficient rainfall, most hill town face water shortages due to lack of provisions for capturing the runoff.

#### *BOX 2.1: When not to do RWH*

Using storage (Surface/ subsurface) structures

- If the gap between rainy days is too large, it may be uneconomical to build storage to cater to the dry period
- Open surface storage structures may not be feasible in case of high rate of evaporation

Using artificial recharge structures

In general, CGWB norm suggests not to do artificial recharge if water table is less than 8 m. However one must also look at trend & future development possibilities, which may exert pressure on ground water resources and plan for recharge accordingly. In any case water table must not be less than 4 m. to avoid any water logging and damage to structure. (Refer State Ground Water Agency and Central Ground Water Board Data)

Artificial recharge is not recommended for aquifers with TDS levels higher than 4000 mg/L or high levels of chemical components such as Nitrate, Fluoride, Arsenic. (Refer State Ground Water Agency and Central Ground Water Board Data). Existence of potential contamination environments such as landfill sites, industries, cemeteries in vicinity also need to be considered.

### 2.9.3.2 At implementation stage

Once the need for rainwater harvesting is established, implementation of rainwater harvesting systems should be carried out as follows:

1. Estimate total annual rainwater harvesting potential using the following formula.

$$\text{Total annual RWH potential (cubic metre)} = \text{Rainfall (m)} \times \text{Area of catchment (square metre)} \times \text{Runoff coefficient} \times \text{filter efficiency}$$

Where,

Rainfall (m) : Annual average rainfall data for at least 10 years is used here. This dataset is available from IMD & should be taken for the nearest station with comparable conditions.

Annual average rainfall for some of the cities in India are given below:

Delhi	= 611.0 mm = 0.61 m
Mumbai	= 2,170 mm = 2.17 m
Chennai	= 1200 mm = 1.2 m
Cochin	= 3099 mm = 3 m
Darjeeling	= 3200 mm = 3.2 m

Area of catchment : Roof Area (sq.m) = Width x Length of Roof.  
In a sloping roof, only the section of the roof to be used for collection is measured.

Run-Off coefficient : Runoff depends upon the area and type of the catchment over which it falls as well as surface features. All calculations relating to the performance of rainwater catchment systems involve the use of runoff coefficient to account for losses due to spillage, leakage, infiltration, catchment surface wetting and evaporation, which will all contribute to reducing the amount of runoff. (Runoff coefficient for any catchment is the ratio of the volume of water that runs off a surface to the volume of rainfall that falls on the surface). Run off coefficients for some surfaces is given in table 2.8

Table 2.9 Runoff coefficients for different surfaces

Surface type	Runoff coefficient
Roofs conventional	0.70 to 0.80
Roofs inclined	0.85 to 0.95
Concrete/Kota Paving	0.60 to 0.70
Gravel	0.50 to 0.60
Brick Paving	0.75
Vegetation	
1%–3%	0.20
3%–10%	0.15
> 10% (more the vegetation cover – less the runoff coefficient)	0.10
Turf slopes	
0%–1%	0.25
1%–3%	0.35
3%–10%	0.40

Surface type	Runoff coefficient
> 10%	0.45

Filter efficiency : The efficiency value shall depend on the type of filter used. There are many filtration systems that can be used. Example of some filter systems are given in section on: “measures to ensure water quality”.

A reference table to estimate rainwater availability for a given roof top area and rainfall is presented below. {Refer Annexure 2.3}

2. Prepare rainwater harvesting site plan with defined catchments and identify location for siting the rainwater harvesting structures.

This would include identification of abandoned bore wells/ dug wells/ ponds, which can be used for the purpose after studying the feasibility. For eg: Abandoned borewells / dugwells may be used as artificial recharge structures after testing the intake rate. Also see box 2.2 .

Box 2.2: Using existing site features for rainwater harvesting  
Existing ponds/ tanks in the development sites hold immense potential for harvesting surface run off. Traditionally these have been common water storage structures for meeting demand for irrigation and cattle. Most ponds/ tanks may have their own catchments, which can serve to arrest surface runoff from the new development if appropriate measures are taken to conserve the natural catchment. These ponds in the modern context can be used for fire fighting/ horticulture by integrating them in the landscaping.  
Alternatively the existing ponds/ tanks, which are often damaged or silted, can be modified to serve as recharge structures

While planning for ground water recharge structures in large scale development projects, the following tools may be used to identify appropriate location for the structures:

Satellite imagery : Satellite data of ground water maps is available from various national agencies such as Space Application Centre, Ahmedabad and NGRI, Hyderabad & concerned State Departments.

Ultrasound seismo-resistivity sub soil investigation method :

This technique is used to determine:

- Location and profile of each aquifer (Commercial availability, time & cost)
  - TDS Concentrations
  - Hardness characteristics
  - Other chemical parameters that are critical like Nitrate, Fluoride, Arsenic, etc.
3. Design storage/recharge structures : Rainfall pattern and quantity is the prime determinant of the type of structures to be constructed for harvesting rainwater in a site. The number of annual rainy days also influences the need and design for rainwater harvesting. The fewer the annual rainy days or longer the dry period, the more the need for

rainwater collection in a region. However, if the dry period is too long, big storage tanks would be needed to store rainwater. Hence in such regions, it is more feasible to use rainwater to recharge groundwater aquifers rather than for storage. The details of the structures are given in Sections 2.9.3.3 and 2.9.3.4.

4. Plan for overflow and drainage and use of the harvested rainwater
5. Vetting of Designs by authorities concerned (if specified in the existing regulation) or by hydrologist/hydrogeologist to ensure aquifer safety and civil engineer/architect to ensure structural safety.
6. Construction to be done by contractors trained and approved by CGWB as per designs specified by CGWB of India.

#### *2.9.2.3 Artificial recharge structures*

In urban areas with the rainfall limited during the monsoon period ( usually from 15-90 days) rooftop rainwater cannot be stored and used as mentioned above and is best used for recharging the ground water ( NBC,2005). Artificial recharge to ground water aims at augmentation of ground water reservoir by modifying the natural movement of surface water utilizing suitable civil construction techniques. The main objectives achieved may be:

- Enhancement of the sustainable yield in areas where there is over-development and depletion of the aquifers.
- Conservation and storage of excess surface water in the aquifers
- Improve the quality of existing ground water through dilution.
- Remove bacteriological and suspended impurities during the surface water transition within the subsoil.
- Maintain the natural balance of the ground water and its usage as the rainwater is a renewable supply source. A well managed and controlled tapping of the aquifers will provide constant, dependable and safe water supply. ( NBC, 2005)

The artificial recharge of ground water is normally recommended in areas where:

- Ground water levels show a declining trend
- Substantial amount of aquifer has already been desaturated.
- Availability of ground water is inadequate in lean months.
- Salinity ingress is taking place.
- Large scale development is planned and the surface water availability is limited.

#### *Basic Requirement for Artificial Recharge :*

In planning and designing the ground water recharge structures following points should be taken into consideration:

1. Annual rainfall (for estimating approx. rainwater recharge per year, as demonstrated in section above).
2. Peak intensity and duration of each storm : For design of recharge structure, hourly runoff i.e. maximum hourly intensity occurring maximum number of time in 5- 10 years is used. (25-35 mm/ hour for Delhi/ Chandigarh/ Bhopal; 30-45 mm/ hr for Bombay/ Chennai/ Kolkatta)  
(This dataset is available from IMD & should be taken for the nearest station with comparable conditions. )
3. Type of soil and subsoil conditions and their permeability factor : Infiltration rates of soil and hydraulic conductivities of water transmission are required to be considered while constructing recharge systems. Infiltration capacity of different soils types are carried out by State agriculture departments and/ or land use survey organisations. This data/ information together with maps showing infiltration rates is usually available in their department reports published periodically and are available with district agriculture officer. At the district level, this information is available in the departmental reports of the Central and State ground water boards. Normally hydraulic conductivities ( K- values) of various soils in m/ day , which can serve the purpose of assessing the final infiltration rates of soils are given in table 2.10. These can be used in the absence of measured values of soils under recharge. K-values however, must be measured for a particular site for efficient results.

Table 2.10 Hydraulic conductivities of soil

S no.	Soils	K- values ( m/ day)
1	Clay surface	0.01-0.2
2	Deep clay layer	$10^{-8}$ - $10^{-2}$
3	Loam	0.1-10
4	Fine sand	1-5
5	Medium sand	5-20
6	Coarse sand	20-100
7	Gravel	100-1000
8	Sand and gravel	5-100
9	Clay, sand & gravel	0.001-0.1

Source: MoWR, Gol, 2004, pg. 15, 84

The infiltration rates for various types of surface soils which facilitate entry into vadose zone are given in table 2.11.

Table 2.11 Infiltration Rate of Different Texture (CM\Hour)

Coarse sand	:	2.00 – 2.50
Lateritic red sandy soil	:	1.50-2.00
Fine sand	:	1.30-2.00
Fine sandy loam	:	1.20
Silty loam	:	1.00
Clay loam	:	0.80
Clay	:	0.50

Table 2.12 Specific Yield of Different Formation

		Yield (%)
Sand	:	10-30
Gravelly Sand (coarse sand)	:	15-30
Sand and Gravel	:	15-25
Sand stone coarse-grained	:	10-15
Sand stone fine-grained	:	5-15
Thick plastic clay	:	3-5
Weathered rock	:	2-5
Clay	:	1-10
Fractured and jointed rock	:	0.50-5

Table 2.13 Typical Porosities of soil

Soil Texture	Porosity
Sandstone	0.19
Sandy loam sub soil	0.36
Sandy loam plough layer	0.42
Clay loam subsoil	0.44
Recently ploughed clay loam	0.58

4. Hydrogeological studies : Detailed knowledge of geological and hydrological features of the area is necessary for adequately selecting the site and the type of recharge structure. In particular, the features, parameters and data to be considered are: geological boundaries; hydraulic boundaries; inflow and outflow of waters; storage capacity; porosity; hydraulic conductivity; transmissivity; natural discharge of springs; water resources available for recharge; natural recharge; water balance; lithology; depth of the aquifer; and tectonic boundaries. The aquifers best suited for artificial recharge are those aquifers which absorb large quantities of water and do not release them too quickly. Theoretically this will imply that the vertical hydraulic conductivity is high, while the horizontal hydraulic conductivity is moderate. These two conditions are not often encountered in nature.

(Source: Guide on Artificial recharge to ground water, Ministry of Water Resources, New Delhi 2000)

Data of existing borewells should also be collected to determine the intake capacity of the recharge wells, which is generally 70% to 80% of the yield of wells in the specified area. (Refer State Ground Water Agency and Central Ground Water Board Data)

5. Location of recharge structures : The basic purpose of artificial recharge of ground water is to restore supplies from aquifers depleted due to excessive ground water development. Some of the structures generally used are:
  - Recharge pits
  - Recharge trenches
  - Recharge shaft
  - Trench with recharge well
  - Shaft with recharge well
  - Recharge through abandoned hand pumps
  - Recharge through abandoned tube well
  - Recharge well
  - Injection well
  - Percolation tank
  - Check dam
  - Gabion bund
  - Sub-surface dyke
  - Roof top rain water harvesting
  - Recharge wells/ tidal regulators to arrest salinity ingress in coastal aquifers

Design details of a few structures are described below.

- Trench with recharge well
- For recharging the shallow as well as deeper aquifers, lateral trench of 1.5 to 3 m wide & 10 to 30 m long depending upon availability of water with one or more bore wells may be constructed. The lateral trench is back filled with boulders, gravels and coarse sand.

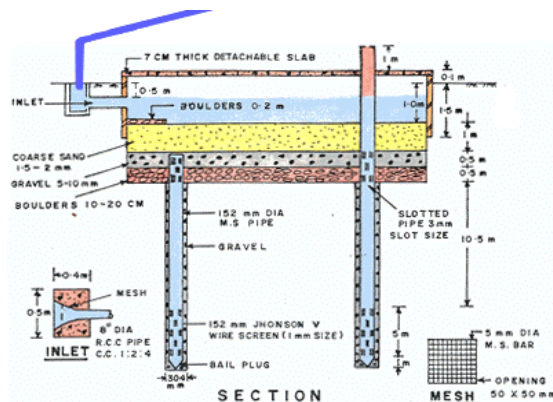

Figure 2.7 Recharge well



Source: Central Ground Water Board

- Shaft with recharge well

In case of aquifer depths greater than 20m or more, shaft of 2 to 5 m diameter and 3 to 5 m deep may be constructed depending upon availability of runoff. Inside the shaft a recharge well of 100 to 300 mm diameter is constructed for recharging the available water to the deeper aquifer. At the bottom of the shaft a filter media is provided to avoid choking of the recharge well.

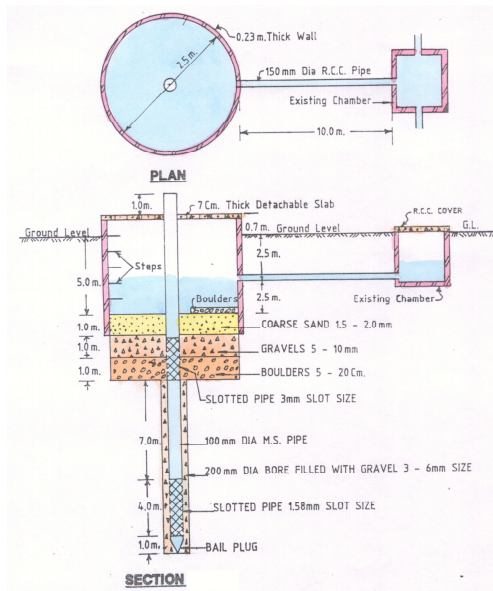

**Figure 2.8 Recharge well shaft**

Source: Central Ground Water Board

- Abandoned tubewell

Abandoned tubewell may be used for recharging the shallow / deep aquifers. These tube wells should be redeveloped before use as recharge structure. Water should pass through filter media before diverting it into recharge tube well.



**Figure 2.9 Abandoned tubewell**

Source: Central Ground Water Board



- Checkdams

Check dams are constructed across small streams having gentle slopes and are feasible both in hard rock and in alluvial formations. The site selected for check dam should have sufficient thickness of permeable bed or weathered formation to facilitate recharge of stored water within short spell of time. The water stored in these structures is mostly confined to stream course. The height is kept at about 1 to 5 meters



**Figure 2.10 : Check dams**

Source: Central Ground Water Board

#### *2.9.3.4 Roof top rainwater harvesting using (surface/ subsurface) Storage structures*

In areas having rainfall of considerable intensity, spread over a large period in a year with short dry spells rainwater harvesting from roof tops is an ideal option for augmenting water supply. Rainwater is essentially bacteriologically pure, free from organic matter and soft in nature and hence can be an ideal solution for areas where there is inadequate ground water supply and surface water resources are either lacking or insignificant. Himalayan region, North-eastern states, Andaman Nicobar, Lakshadweep islands and southern parts of Kerala and Tamil Nadu are the regions where rainwater can be usefully harvested and stored in suitable storage tanks (surface / sub surface). The water is collected through roof gutters and down take pipes. In case of storage structures, the size of the tanks should ideally be enough to supply sufficient water during the dry (non rainy) period. Factors considered in design include demand, duration of dry spell, catchment area available and rainfall. Assuming a full tank at the beginning of the dry season (and knowing the average length of the dry season and average water use) the volume of the tank can be calculated by the following formula:

$$V = (T \times N \times Q) + Et$$

Where,

V= volume of the tank (litres)

T= length of the dry season (days)

N= number of people using the tank

Q= consumption per capita per day ( litres)

Et= evaporation loss during dry period (which may be ignored in case of closed storage tanks)

( MoRD, GoI, 2004)

The five main site conditions to be assessed in case of (surface/ subsurface) storage structures are:

- Availability of suitable catchments (Rooftops are usually recommended as against surface catchments in this case as quality control measures can be relatively easier to apply and monitor).
- Foundation characteristics of soil near the house
- Location of trees
- Estimated runoff to be captured per unit of the catchment
- Availability and location of construction material (MoRD, GoI, 2004)

#### *Measures to ensure water quality*

Rainwater is generally devoid of any impurities and can ensure good quality water if certain precautions are taken. These include :

- Catchments such as roofs should be accessible for regular cleaning and ensuring no dead animals etc are present on the surface.
- The roof should be made of non- toxic material, have smooth, hard and dense surface which is less likely to be damaged allowing release of material into the water. Roof painting is no advisable since most paints contain toxic substances and may peel off.
- All gutter ends must be fitted with a wire mesh screen and a first flush device must be installed. Most of the debris carried by the water from the rooftop like leaves, plastic bags and paper pieces can be arrested by the mesh at the terrace outlet and contamination can be prevented to a large extent by ensuring that the runoff from the first 10-20 minutes of rainfall is flushed off. Remaining contaminants like silt and blow dirt can be removed by installing appropriate filters. (Refer Annexure 2.3 on details of filtration systems”)
- No sewage or wastewater should be admitted into the system.
- No wastewater from areas likely to have oil, grease, or other pollutants should be connected to the system. For runoff from parking lots and roads, grease filters etc may be necessary to prevent risk of contamination from chemical spillage.

Some specific measures with respect to artificial recharge structures and storage tanks are listed below :

*In case of artificial recharge structures,*

- Each structure/ well should have an inlet chamber with a silt trap to prevent any silt from finding its way into the sub soil water.- The wells should be terminated at least 5 mt above the natural static sub soil water at its highest level so that the incoming flow passes through the natural ground condition and prevents contamination hazards. ( NBC, 2005)
- It needs to be ensured that no recharge structure or a well is used for drawing water for any purpose.

*In case of surface / subsurface storage tanks,*

- The location of the tank should be such that it is not exposed to any hazard of water contamination from any other sources.
- Appropriate measures for disinfection and maintaining quality of the stored water such as chlorination must be used. In case of chlorination, water shall be chlorinated maintaining a residual chlorine of approximately 1mg/l.
- The tank must have an overflow leading to a natural water course or to any additional tank or ground water recharge structure. (Also see box 4)
- At the end of the dry season just before the onset of the rains, the storage tank should be flushed of all sediments and debris ( the tank should be re-filled afterwards with a few centimetres of clean water to prevent cracking). Ensure timely service (before the first rains are due) of all the tank features, including replacement of all worn screens etc. It is also advisable to monitor rainwater quality periodically to check presence of air pollutants, which may be addressed specifically if occurring at frequent intervals.

Box4: Integrating storage with ground water recharge in Germany

In Germany there is currently a growing interest in the promotion of rainwater collection particularly at local government level. Due to serious industrial air pollution and strict regulations regarding drinking water standards, household rainwater supplies are limited to non-potable uses such as toilet flushing, clothes washing, and garden watering. In addition to reducing overall domestic water demand, benefits from rainwater utilization include flood control and reduced stormwater drainage capacity requirements. When used in conjunction with a seepage well to return any overflow to the ground, the systems also enhance groundwater recharge. Most storage tanks are constructed underground and recent designs incorporate a porous ring at the top of the tank so when it is more than half full, water seeps back into the ground. The main advantage of designing rainwater collection systems in this way or in conjunction with seepage wells is that many German cities charge householders an annual rainwater drainage fee, which is waived if rainwater runoff is retained or returned to the ground allowing significant savings.

Source : Source: Gauld, 1999

## Annexure 2.1 Drought Resistant Plants

Tree species	Common Name	Annual rainfall required		Drought resistance	
		Minimum	Maximum	During Planting	Mature Tree
<i>Prosopis cineraria</i>	Khejri	75	800	8	10
<i>Capparis deciduas</i>	Kiari , Caperbrush	100	1500	9	10
<i>Tamarix aphylla</i>		100	500	8	10
<i>Acacia tortillas</i>		100	1000	10	10
<i>Zizyphus nummularia</i>	Jungli Ber	125	2225	6	10
<i>Prosopis juliflora</i>	Kikar	150	750	10	10
<i>Tecomella undulata</i>	Rugtora/Wavy leafed Tufmella	150	500	8	10
<i>Colophospermum mopane</i>		150	800	8	10
<i>Salvadora oleoides</i>		180	1000	8	10
<i>Acacia aneura</i>		200	500	9	10
<i>Parkinsonia aculeate</i>		200	1000	8	10
<i>Dichrostachys cineraria</i>		200	700	8	10
<i>Acacia holosericea</i>		200	1500	8	9
<i>Borassus flabellifera</i>	Tar	?20	1000	6	8
<i>Grewia tenax</i>	Falsa	200	1000	5	7
<i>Commiphora wightii</i>	Guggal	225	500	7	10
<i>Acacia seyal</i>		250	1000	7	9
<i>Eucalyptus camaldulensis</i>	Eucalyptus	250	2000	7	8
<i>Hardwickia binnata</i>		250	1500	7	8
<i>Pithecelobium dulce</i>	Jungle Jalebi	?250	1250	6	7
<i>Celtis australis</i>		250	800	5	6
<i>Acacia albida</i>		300	1800	8	10
<i>Albizia lebbek</i>	Shirish	300	2500	8	8
<i>Acacia nilotica</i>	Babul	350	2000	8	9
<i>Acacia ferruginea</i>		350	750	7	9
<i>Casuarina equisetifolia</i>	Jhar	350	5000	7	8
<i>Leucaena leucocephala</i>	Subabul	350	2000	5	6
<i>Melea azedirach</i>		350	2000	6	7
<i>Sesbania grandiflora</i>		350	1200	5	6
<i>Tamarindus indica</i>	Imli	350	1500	5	8
<i>Wrightia Tinctoria</i>		400	800	8	10
<i>Morus indica/alba</i>	Mulberry	400	2000	6	10
<i>Ailanthus excelsa</i>		400	850	7	8
<i>Dalbergia sissoo</i>	Sheesham	400	4500	6	8
<i>Anona squamosa</i>	Custard Apple	400	2000	7	9
<i>Emblica officinalis</i>	Amla	400	2500	6	8
<i>Anogeissus pendula</i>		425	875	7	8
<i>Acacia leucophaloea</i>		450	1500	6	9
<i>Azadirachta indica</i>	Neem	450	1150	7	8
<i>Diospyros melanoxylon</i>	Tendu	450	1500	7	8
<i>Ougeinia oojeinensis</i>		450	1750	5	6
<i>Commiphora caudata</i>		500	850	7	10
<i>Bauhinia variegata</i>	Kachnar	500	2750	7	9
<i>Eucalyptus tereticornis</i>		500	1500	7	7

Tree species	Common Name	Annual rainfall required		Drought resistance	
		Minimum	Maximum	During Planting	Mature Tree
Pongamia Pinnata	Karanj	500	2500	7	7
Casia siamea		500	700	6	7
Anacardium occidentale	Cashew	500	3500	6	8
Holoptelia integrifolia		500	2000	7	8
Acacia catechu	Katha	500	2000	5	7
Boswellia serrata	Lobaw	500	1250	6	7
Butea monosperma	Palash	500	4500	6	6
Casseea fistula	Amaltas	500	3000	6	6
Albizia amara		500	1000	6	7
Dalbergia latifolia	Eastern Rosewood	500	5000	5	6
Erythrina Indica	Coral Tree	500	1500	5	6
Ficus bengalensis	Banyan	500	4000	6	7
Ficus religiosa	Peepal	500	5000	6	7
Santalum album	Sandal	500	1500	6	7
Syzygium cuminii	Clove	500	5000	5	5
Terminalia alata		500	3650	5	6
Madhuca latifolia	Mahua	550	1500	8	9
Acacia auriculiformis		600	1800	6	6
Terminalia bellirica	Harad	600	3000	5	6
Dendrocalamus strictus	Lathi Baans	750	5000	5	6
Moringa oleifera	Drumstick	750	2000	5	5
Terminalia arjuna	Arjun	750	1750	5	5

## Annexure 2.2 : Native species for different agro-climatic zones

### Central Highlands

Agro-climatic zone	Central Highlands (1)	Central Highlands (2)
Soil type	Red and black soils	Medium to dark black soils
Climatic condition	Sub-humid	Semi-arid
<b>Shrubs with fragrant flowers</b>	Lawsonia alba Nyctanthes arbortristis Thevetia neriifolia	Tabernaemontana coronaria Lawsonia alba Nyctanthes arbortristis Mimusops elengi Murraya exotica Cestrum nocturnum Thevetia neriifolia
<b>Ornamental and flowering trees</b>	Cochlospermum gossypium Terminalia arjuna Lagerstroemia flosreginae L. thorellii Peltophorum inerme Butea frondosa Bauhinia purpurea B. tomentosa B. triandra B. variegata B. acuminata B. corymbosa B. alba Browne coccinia B. ariza B. grandiceps Cassia fistula C. javanica Caesalpinioideae nodosa Poinciana elata Pongamia glabra Hibiscus collinus Kydia calycina Ficus bengalensis Moringa oleifera Madhuka latifolia Pithecolobium dulce Mangifera indica Bamboo sps	Jacaranda mimosaefolia Cochlospermum gossypium Terminalia arjuna Lagerstroemia flosreginae L. thorellii Peltophorum inerme Butea frondosa Bauhinia purpurea B. tomentosa B. triandra B. variegata B. acuminata B. corymbosa B. alba Browne coccinia B. ariza B. grandiceps Cassia fistula C. javanica Caesalpinioideae nodosa Milletia ovalifolia Poinciana elata Pongamia glabra Hibiscus collinus Kydia calycina Ficus bengalensis Moringa oleifera Madhuka latifolia Pithecolobium dulce Mangifera indica Bamboo sps

## Deccan Plateau

	Deccan Plateau (3)	Deccan Plateau (4)	D eccan Plateau (5)
Agro-climatic zone	Deccan Plateau (3)	(4)	eccan Plateau (5)
Soil type	Red and black soils	Black soils	Red and black soils
Climatic condition	Arid	Semi-arid	Semi arid
<b>Shrubs with fragrant flowers</b>	Tabernaemontana coronaria	Tabernaemontana coronaria Lawsonia alba	Tabernaemontana coronaria
	Nyctanthes arbortristis	Lam Hiptage	Hiptage madablota Nyctanthes arbortristis
	Murraya exotica	madablota Nyctanthes arbortristis Gardenia florida G.lucida G. latifolia G. latifolia Ixora parviflora Gardenia resinifera Gardenia resinifera Anthocephalus cadamba Mimusops elengi Mimusops elengi Murraya exotica Cestrum nocturnum Cestrum nocturnum Thevetia neriifolia Thevetia neriifolia	arbortristis Gardenia florida G.lucida G. latifolia Ixora parviflora Gardenia resinifera Anthocephalus cadamba Mimusops elengi Murraya exotica Cestrum nocturnum Thevetia neriifolia
<b>Ornamental and flowering trees</b>	Terminalia arjuna	Plumeria acutifolia	Plumeria acutifolia
	Lagerstroemia flosreginae	P. rubra	P. rubra
	L. thorellii	P. alba	P. alba
	Bauhinia purpurea	Bignonia crispa Jacaranda	Bignonia crispa Jacaranda
	B. tomentosa	mimosaeifolia Spathodea	mimosaeifolia Spathodea
	B. triandra	campanulata Millingtonia	campanulata Millingtonia hortensis
	B. variegata	hortensis Cochlospermum gossypium	Millingtonia hortensis Cochlospermum gossypium
	B. acuminata	gossypium	gossypium
	B. corymbosa	Cordia sebestena	Cordia sebestena
	B. alba	Terminalia arjuna	Terminalia arjuna
	Browne coccinia	Crataeva religiosa Lagerstroemia flosreginae	Crataeva religiosa Lagerstroemia flosreginae
	B. ariza	flosreginae	flosreginae
	B. grandiceps	L. thorellii Enterolobium	L. thorellii Enterolobium saman
	Peltophorum ferrugineum	saman	Enterolobium saman

Agro-climatic zone	Deccan Plateau (3)	Deccan Plateau (4)	D eccan Plateau (5)
Soil type	Red and black soils	Black soils	Red and black soils
Climatic condition	Arid	Semi-arid	Semi arid
	Poinciana elata	Peltophorum inerme	Peltophorum inerme
	Pongamia glabra	Butea frondosa	Butea frondosa
	Mangifera indica	Bauhinia purpurea	Bauhinia purpurea
	Bamboo sps	B. tomentosa	B. tomentosa
		B. triandra	B. triandra
		B. variegata	B. variegata
		B. acuminata	B. acuminata
		B. corymbosa	B. corymbosa
		B. alba	B. alba
		Browne coccinia	Browne coccinia
		B. ariza	B. ariza
		B. grandiceps	B. grandiceps
		Cassia fistula	Cassia fistula
		C. javanica	C. javanica
		Caesalpinioideae nodosa	Caesalpinioideae nodosa
		Gliricidia maculata	Gliricidia maculata
		Milletia ovalifolia	Milletia ovalifolia
		Enterolobium saman	Enterolobium saman
		Peltophorum ferrugineum	Peltophorum ferrugineum
		Saraca indica	Saraca indica
		Poinciana regia	Poinciana regia
		Poinciana elata	Poinciana elata
		Pongamia glabra	Pongamia glabra
		Pterocarpus indicus	Pterocarpus indicus
		Hibiscus collinus	Hibiscus collinus
		Kydia calycina	Kydia calycina
		Thespesia populnea	Thespesia populnea
		Ficus bengalensis	Ficus bengalensis
		Moringa oleifera	Moringa oleifera
		Madhuka latifolia	Madhuka latifolia
		Guaiacum officinale	Sterculia foetida
		Terminalia catappa	Guaiacum officinale
		Pithecolobium dulce	Pithecolobium dulce
		Mangifera indica	Mangifera indica
		Bamboo sps	Bamboo sps



		Deccan Plateau (4)	D Deccan Plateau (5)
Agro-climatic zone	Deccan Plateau (3)	(4)	Deccan Plateau (5)
Soil type	Red and black soils	Black soils	Red and black soils
Climatic condition	Arid	Semi-arid	Semi arid
<b>Trees with ornamental foliage</b>		Polyalthia longifolia	Polyalthia longifolia
	Tamarindus indica	Putranjiva roxburghii	Putranjiva roxburghii
	Azadirachta indica	Tamarindus indica	Tamarindus indica
		Acacia auriculiformis	Acacia auriculiformis
		Azadirachta indica	Azadirachta indica
		Moringa pterygosperma	Moringa pterygosperma
		Callistemon lanceolatus	Callistemon lanceolatus
		Eucalyptus citriodora	Eucalyptus citriodora
<b>Shade trees</b>	Tamarindus indica	Tamarindus indica	Azadirachta indica
	Azadirachta indica	Azadirachta indica	Azadirachta indica
		Mangifera indica	Mangifera indica

### Eastern Plains

Agro-climatic zone	Eastern coastal plain (6)	Eastern Plain (8)	Eastern Plain (9)
Soil type	Alluvium	Alluvium derived soils	Red and yellow soils
Climatic condition	Sub-humid	Subhumid	Perhumid-subhumid
<b>Shrubs with fragrant flowers</b>	Artabotrysodoratissimus		Artabotrysodoratissimus
	Hiptage madablota		Magnolia grandiflora
	Ixora parviflora		Michelia champaca
	Gardenia resinifera		Ixora parviflora Anthocephalus cadamba
<b>Ornamental and flowering trees</b>	Plumeria acutifolia	Dillenia indica	Plumeria acutifolia
	P. rubra		P. rubra
	P. alba		P. alba
	Bignonia crispa		Bignonia crispa
	Dillenia indica		Jacaranda mimosaeifolia

Agro-climatic zone	Eastern coastal plain (6)	Eastern Plain (8)	Eastern Plain (9)
Soil type	Alluvium	Alluvium derived soils	Red and yellow soils
Climatic condition	Sub-humid	Subhumid	Perhumid-subhumid
	Lagerstroemia flosreginae		Millingtonia hortensis
	L. thorellii		Dillenia indica
	Amherstia nobilis		Lagerstroemia flosreginae
	Enterolobium saman		L. thorellii
	Cassia fistula		Amherstia nobilis
	C. javanica		Enterolobium saman
	Caesalpinioideae nodosa		Butea frondosa
	Gliricidia maculata		Cassia fistula
	Enterolobium saman		C. javanica
	Peltophorum ferrugineum		Caesalpinioideae nodosa
	Saraca indica		Erythrina indica
	Poinciana regia		E. Blakei
	Pterocarpus indicus		E. crista-galli
	Thespesia populnea		Enterolobium saman
	Mussaenda glabrata		Peltophorum ferrugineum
	Casuarina equisetifolia		Saraca indica
			Poinciana regia
			Poinciana elata
			Pongamia glabra
			Kydia calycina
			Chorisia speciosa
			Thespesia populnea
			Ficus bengalensis
			Moringa oleifera
			Madhuka latifolia
			Sterculia foetida
			Mesua ferra
			Bamboo sps
<b>Trees with ornamental foliage</b>	Polyalthia longifolia	Sapium sebiferum	Polyalthia longifolia
	Putranjiva roxburghii	Grevillea robusta	Putranjiva roxburghii
	Casuarina equisetifolia		Azadirachta indica
			Melia azedarach
			Moringa
			plerygosperma
<b>Shade trees</b>	Casuarina equisetifolia	Grevillea robusta	Azadirachta indica
			Melia azedarach

## Eastern Plateau

Agro-climatic zone	Eastern Ghats Tamil Nadu Uplands (7)	Eastern Plateau (10)	Eastern Plateau (11)
Soil type	Red loamy soils	Red and lateritic soils	Red and yellow soils
Climatic condition	Semi-arid	Sub-humid	Sub-humid
<b>Shrubs with fragrant flowers</b>	Tabernaemontana coronaria Hiptage madablota Nyctanthes arbortristis Gardenia florida G.lucida G. latifolia Ixora parviflora Gardenia resinifera Anthocephalus cadamba Mimusops elengi Murraya exotica Cestrum nocturnum	Tabernaemontana coronaria Gardenia florida G.lucida G. latifolia Ixora parviflora Anthocephalus cadamba Mimusops elengi Cestrum nocturnum	Tabernaemontana coronaria Lawsonia alba Lam Gardenia florida G.lucida G. latifolia Mimusops elengi Thevetia nerifolia
<b>Ornamental and flowering trees</b>	Plumeria acutifolia P. rubra P. alba Bignonia crispa Millingtonia hortensis Cochlospermum gossypium Terminalia arjuna Crataeva religiosa Dillenia indica Lagerstroemia flosreginae L. thorellii Enterolobium saman Butea frondosa Bauhinia purpurea B. tomentosa B. triandra B. variegata B. acuminata B. corymbosa B. alba Browne coccinia B. ariza	Plumeria acutifolia P. rubra P. alba Bignonia crispa Millingtonia hortensis Cochlospermum gossypium Cordia sebestena Terminalia arjuna Crataeva religiosa Dillenia indica Lagerstroemia flosreginae L. thorellii Amherstia nobilis Enterolobium saman Butea frondosa Bauhinia purpurea B. tomentosa B. triandra B. variegata B. acuminata B. corymbosa B. alba B. corymbosa B. alba	Jacaranda mimosaeifolia Cochlospermum gossypium Cordia sebestena Terminalia arjuna Lagerstroemia flosreginae L. thorellii Butea frondosa Bauhinia purpurea B. tomentosa B. triandra B. variegata B. acuminata B. corymbosa B. alba Browne coccinia B. ariza B. grandiceps Cassia fistula C. javanica Caesalpinioideae nodosa Saraca indica Poinciana regia

B. grandiceps	Browne coccinia	Pongamia glabra
Cassia fistula	B. ariza	Hibiscus collinus
C. javanica	B. grandiceps	Kydia calycina
Caesalpinioideae nodosa	Cassia fistula	Thespesia populnea
Gliricidia maculata	C. javanica	Ficus bengalensis
Milletia ovalifolia	Caesalpinioideae nodosa	Moringa oleifera
Enterolobium saman	Erythrina indica	Madhuka latifolia
Peltophorum ferrugineum	E. Blakei	
Saraca indica	E. crista-galli	
Poinciana regia	Enterolobium saman	
Poinciana elata	Peltophorum ferrugineum	
Pongamia glabra	Saraca indica	
Pterocarpus indicus	Poinciana elata	
Hibiscus collinus	Pongamia glabra	
Kydia calycina	Hibiscus collinus	
Thespesia populnea	Kydia calycina	
Moringa oleifera	Chorisia speciosa	
Mussaenda glabrata	Thespesia populnea	
Madhuka latifolia	Ficus bengalensis	
Sterculia foetida	Moringa oleifera	
Guaiacum officinale	Madhuka latifolia	
Casuarina equisetifolia	Sterculia foetida	
Bamboo sps	Mangifera indica	
	Morus alba	
	Bamboo sps	

**Trees with ornamental foliage**

Polyalthia longifolia	Polyalthia longifolia	Polyalthia longifolia
Putranjiva roxburghii	Putranjiva roxburghii	Putranjiva roxburghii
Tamarindus indica	Tamarindus indica	Tamarindus indica
Acacia auriculiformis	Acacia auriculiformis	Acacia auriculiformis
Azadirachta indica	Azadirachta indica	Azadirachta indica
Moringa plerygosperma	Moringa plerygosperma	Melia azedarach
Callistemon lanceolatus	Callistemon lanceolatus	Moringa plerygosperma
Eucalyptus citriodora	Eucalyptus citriodora	Eucalyptus citriodora
Tamarindus indica	Eugenia cuspidata	Melia azedarach
Azadirachta indica	Tamarindus indica	Tamarindus indica

**Shade trees**

## Northern Region and North Eastern Hills

Agro-climatic zone	North Eastern Hills (12)	Northern Plain (13)	Northern Plain (14)
Soil type	Red and lateritic soils	Alluvium derived soils	Alluvium derived soils
Climatic condition	Perhumid	Semi-arid	Sub-humid
<b>Shrubs with fragrant flowers</b>	Artabotrysodoratissimus	Tabernaemontana coronaria	Tabernaemontana coronaria
	Magnolia grandiflora	Hiptage madablota	Lawsonia alba Lam Magnolia
	Michelia champaca	Nyctanthes arbortristis	grandiflora
	Ixora parviflora	Gardenia florida G.lucida G. latifolia Ixora parviflora Anthocephalus cadamba Mimusops elengi Murraya exotica Citrus aurantium Cestrum nocturnum Thevetia neriifolia	Gardenia florida G.lucida G. latifolia Ixora parviflora Anthocephalus cadamba Mimusops elengi Murraya exotica Citrus aurantium
<b>Ornamental and flowering trees</b>	Plumeria acutifolia P. rubra  P. alba  Dillenia indica Lagerstroemia flosreginae  L. thorellii  Amherstia nobilis  Enterolobium saman Cassia fistula C. javanica Caesalpinioideae nodosa Enterolobium saman Peltophorum ferrugineum Saraca indica Poinciana regia	Plumeria acutifolia P. rubra  P. alba Jacaranda mimosaeolia S. nilotica  Millingtonia hortensis Cochlospermum gossypium  Cordia sebestena Terminalia arjuna Crataeva religiosa Lagerstroemia flosreginae L. thorellii  Peltophorum inorme Butea frondosa Bauhinia purpurea	Jacaranda mimosaeolia S. nilotica Cochlospermum gossypium  Terminalia arjuna Crataeva religiosa Lagerstroemia flosreginae L. thorellii Peltophorum inorme Cassia fistula C. javanica Caesalpinioideae nodosa Erythrina indica E. Blakei E. crista-galli Poinciana regia

Agro-climatic zone	North Eastern Hills (12)	Northern Plain (13)	Northern Plain (14)
Soil type	Red and lateritic soils	Alluvium derived soils	Alluvium derived soils
Climatic condition	Perhumid	Semi-arid	Sub-humid
	Mesua ferra	B. tomentosa	Poinciana elata
	Bamboo sps	B. triandra	Pongamia pinnata
	Anthocephalus cadamba	B. variegata	Hibiscus collinus
	Saraca indica	B. acuminata	Kydia calycina
		B. corymbosa	Chorisia speciosa
		B. alba	Ficus bengalensis
		Browne coccinia	Moringa oleifera
		B. ariza	Morus alba
		B. grandiceps	Bamboo sps
		Cassia fistula	
		C. javanica	
		Caesalpinioideae nodosa	
		Erythrina indica	
		E. Blakei	
		E. crista-galli	
		Milletia ovalifolia	
		Poinciana regia	
		Poinciana elata	
		Pongamia pinnata	
		Hibiscus collinus	
		Kydia calycina	
		Thespesia populnea	
		Ficus bengalensis	
		Moringa oleifera	
		Dalbergia sissoo	
		Pithecolobium dulce	
		Morus alba	
		Bamboo sps	
<b>Trees with ornamental foliage</b>	Delonix regia	Polyalthia longifolia	Polyalthia longifolia
		Anogeissus pendula	Putranjiva roxburghii
		Putranjiva roxburghii	Tamarindus indica
		Tamarindus indica	Acacia auriculiformis
		Acacia auriculiformis	Azadirachta indica
		Azadirachta indica	Moringa plerygosperma
		Melia azedarach	Callistemon

Agro-climatic zone	North Eastern Hills (12)	Northern Plain (13)	Northern Plain (14)
Soil type	Red and lateritic soils	Alluvium derived soils	Alluvium derived soils
Climatic condition	Perhumid	Semi-arid	Sub-humid
Shade trees	Delonix regia	Diospyros embryopteris Eugenia cuspidata Ficus infectoria F. retusa Dalbergia sissoo	Eugenia cuspidata Ficus infectoria F. retusa

### Western Region

Agro-climatic zone	Western Ghat (15)	Western Himalayas (16)	Western Himalayas (17)	Western Plain (18)
Soil type	Red and laterite soils	Brown soils and podzolic soils	Shallow skeletal soils	Desert and saline soils
Climatic condition	Perhumid to subhumid	Sub-humid	Arid	Arid
<b>Shrubs with fragrant flowers</b>	Artabotrysodoratis simus Hiptage madablota Nyctanthes arbortristis Gardenia resinifera Murraya exotica			Lawsonia alba Lam  Thevetia neriifolia
<b>Ornamental and flowering trees</b>	Plumeria acutifolia P. rubra P. alba Bignonia crispa Spathodea campanulata Crataeva religiosa Dillenia indica Lagerstroemia	Salix spp Pinusspp Cedrus deodara Rhododendron Aurocaria Abies Picea	Salix spp Pinus spp Cedrus deodara Rhododendron Abies Picea Aurocaria Platanus	Tecomella undulata Peltophorum inerme Butea frondosa Ficus bengalensis Pithecolobium dulce Prosopis cineraria Acacia nilotica Acacia tortilis

	Western Himalayas			
Agro-climatic zone	Western Ghat (15)	Himalayas (16)	(17)	Western Plain (18)
Soil type	Red and laterite soils	Brown soils and podzolic soils	Shallow skeletal soils	Desert and saline soils
Climatic condition	Perhumid to subhumid	Sub-humid	Arid	Arid
	flosreginae		kashmeriana [Chinar]	
	L. thorellii			Salvadora persica
	Enterolobium saman			Azadirachta indica
	Bauhinia purpurea			
	B. tomentosa			
	B. triandra			
	B. variegata			
	B. acuminata			
	B. corymbosa			
	B. alba			
	Browne coccinia			
	B. ariza			
	B. grandiceps			
	Cassia fistula			
	C. javanica			
	Caesalpinioideae			
	nodosa			
	C. renigera			
	Gliricidia maculata			
	Enterolobium saman			
	Peltophorum ferrugineum			
	Poinciana regia			
	Pterocarpus indicus			
	Kydia calycina			
	Thespesia populnea			
	Mussaenda glabrata			
	Madhuka latifolia			
	Sterculia foetida			
	Casuarina equisetifolia			
	Bamboo sps			
<b>Trees with ornamental foliage</b>	Polyalthia longifolia	Sapium sebiferum		Anogeissus pendula



Agro-climatic zone	Western Himalayas			
	Western Ghat (15)	Himalayas (16)	(17)	Western Plain (18)
Soil type	Red and laterite soils	Brown soils and podzolic soils	Shallow skeletal soils	Desert and saline soils
Climatic condition	Perhumid to subhumid	Sub-humid	Arid	Arid
	Putranjiva roxburghii			Azadirachta indica
	Moringa pterygosperma			Eucalyptus citriodora
	Bamboo sps			

### Annexure 2.3 : Rain water run-off for different roof top areas

Rain Fall in mm >	100	200	300	400	500	600	700	800	900	1000	1100	1200	1300	1400	1500	1600	1700	1800	1900	2000
Roof Top Area m <sup>2</sup> ↓	Harvested water from Roof Tops m <sup>3</sup> (80% of gross precipitation)																			
20	2	3	5	6	8	10	11	13	14	16	18	19	21	22	24	26	27	29	30	32
30	2	5	7	10	12	14	17	19	22	24	26	29	31	34	36	38	41	43	46	48
40	3	6	10	13	16	19	22	26	29	32	35	38	42	45	48	51	54	58	61	64
50	4	8	12	16	20	24	28	32	36	40	44	48	52	56	60	64	68	72	76	80
60	5	10	14	19	24	29	34	38	43	48	53	58	62	67	72	77	82	86	91	96
70	6	11	17	22	28	34	39	45	50	56	62	67	73	78	84	90	95	101	106	112
80	6	13	19	26	32	38	45	51	58	64	70	77	83	90	96	102	109	115	122	128
90	7	14	22	29	36	43	50	58	65	72	79	86	94	101	108	115	125	134	144	154
100	8	16	24	32	40	48	56	64	72	80	88	96	104	112	120	128	136	144	152	160
110	9	18	26	35	44	53	62	70	79	88	97	106	114	123	132	141	150	158	167	176
120	10	19	29	38	48	58	67	77	86	96	106	115	125	134	144	154	163	173	182	192
130	10	21	31	42	52	62	73	83	94	104	114	125	135	146	156	166	177	187	198	208
140	11	22	34	45	56	67	78	90	101	112	123	134	146	157	168	179	190	202	213	224
150	12	24	36	48	60	72	84	96	108	120	132	144	156	168	180	192	204	216	228	240
200	16	32	48	64	80	96	112	128	144	160	176	192	208	224	240	256	272	288	304	320
250	20	40	60	80	100	120	140	160	180	200	220	240	260	280	300	320	340	360	380	400
300	24	48	72	96	120	144	168	192	216	240	264	288	312	336	360	384	408	432	456	480
400	32	64	96	128	160	192	224	256	288	320	352	384	416	448	480	512	544	576	608	640
500	40	80	120	160	200	240	280	320	360	400	440	480	520	560	600	640	680	720	760	800
1000	80	160	240	320	400	480	560	640	720	800	880	960	1040	1120	1200	1280	1360	1440	1520	1600
2000	160	320	480	640	800	960	1120	1280	1440	1600	1760	1920	2080	2240	2400	2560	2720	2880	3040	3200
3000	240	480	720	960	1200	1440	1680	1920	2160	2400	2640	2880	3120	3360	3600	3840	4080	4320	4560	4800

## Annexure 2.4 : Details of filtration systems

The following section gives details of a few filtration systems, which can be used during conveyance of harvested water before it enters the storage tank or recharge structures:

### 1. Pop up filter

PopUp Filter is a form of first flush device, which includes three components namely rainwater receptor, flush valve, and filter element. Rainwater receptor is where the rainwater is allowed to flow from down pipes and a flush valve is provided to flush the first flow of the rainwater along with leaves, dust etc. Water received in the receptor flows upwards against gravity through a filter element to filter most floating elements and allow water to stabilize in this filtration zone. Rainwater passing through this filter element (which is relatively cleaner), flows out through an outlet, which can lead to storage device. Filter element is mounted on a vertical stabilizer pipe with a friction fit. In the normal course, rainwater gets filtered and flows through outlet into the storage device. Filter element needs to be cleaned periodically during the rainy season to remove the material and to keep the filtration system clean. In the event where the filter is not cleaned and the filter element is getting clogged, the 'PopUp Filter' has a built-in safety feature to push out the filter element from the stabilizer pipe and allow the water to flow out freely. This safety feature will avoid flooding of the rooftop because of clogged filter. The first indication of the filter getting clogged is rainwater flowing out of a vent hole provided on the top of the filter element. These pop up filters are simple in design and are very flexible to install in varying field conditions.

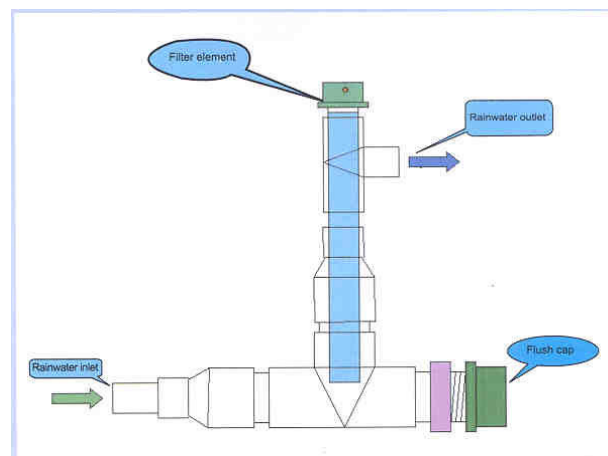

## 2. Sand bed filter

Sand Bed filter is a simple filtration system, which includes layers of pebbles, aggregates and coarse riverbed sand laid one over other in a confined masonry structure. Rainwater is allowed on the top from one end and filtered water is drawn from the other end.

## 3. Stabilization tank

Stabilisation tanks can be used to trap light and heavy impurities without having any filter media, especially in case of large volumes of water. Rainwater is allowed to flow through a series of small tanks and by providing an entry and exit for water at strategic positions, impurities can be trapped in the stabilization tanks for subsequent cleaning. Heavier impurities will get trapped in the first two tanks as the water flows out at the higher level. Lighter and floating impurities get trapped in the third and fourth tanks as the water flows out at the bottom or lower level. Periodic cleaning of these tanks is required to remove the impurities.

(Source: KSCST, IIS, Amruthavarshini: A guide for rainwater harvesting, Bangalore 2005)

## 4. Oil and grease filter

Rainwater Harvester, which filters runoff water from roads, which generally contains oil and grease has been developed by EA water Pvt. Ltd. This system has a sand filter, which filters silt from runoff harvested from roof, lawns and parking area. The cost of the filter is around Rs 60,000.

Source : [www.eawater.com](http://www.eawater.com)

## Reference :

1. National Building Code of India, 2005
2. Rajiv Gandhi National Drinking water mission, Technical document on Water harvesting and Artificial recharge, Delhi, December 2004. (p.45)
3. Assessment of water supply options, contributing paper on Rainwater harvesting submitted to the World Commission on Dams, Gould John, 1999. (<http://www.dams.org/docs/kbase/contrib/opt163.pdf>)
4. Shivakumar A.R, Amruthavarshini- A guide for rainwater harvesting, Karnataka State Council for Science & Technology, IIS, Bangalore, 2005
5. Central Ground Water Board publications
6. TERI–Green Rating for Integrated Habitat Assessment



## Chapter 3 Managing transport including noise and air

### 3.0 Introduction

Transportation and operation of construction machinery are integral part of large construction projects. Any large construction site is never an individual unit, but it is a part of city's system. Road layout affects the users and use patterns on one hand and the operation of construction machinery affect the people residing or working near the site on the other. Both of these activities affect the environment. Right from the commencement of the work, the transportation system and construction activities have to interact with the existing system of the city. This interaction with city's system might be in terms of resource consumption or in the form of power and energy usage, transportation (materials and labour) or the environmental impacts. It is required that these activities may not disturb the balance of city's system in terms of environment and resource consumption.

Some of the factors are important and must be taken into the consideration, while planning, i.e., these activities are generator of noise and air pollution. There is a risk of surface erosion by heavy traffic loads and operation of construction machinery as well. Construction machinery due to its operation produces smoke, dust and noise and vibration. To minimize these negative impacts it is important to design a transportation system with considerations for environment. The design and operational mechanism of Transportation system should aim at easy and fast movement. It should also aim at protection of the site from noise and air pollution on one hand and encouraging the use of non-motorized vehicular movement on the other. This chapter deals with the management of transport and construction activities for reduction of its negative impact on environment.

### 3.1 Scope

The sources of noise and air pollution due to transportation and construction activities can be classified under three heads.

- Use of heavy machineries and vehicles during construction and demolition
- Use of transportation during building operation period
- Operation of D.G. sets

Based over these three heads, the guideline for managing transport (including noise and air) are divided into two parts, first is the planning, i.e., pre-construction stage and second is the construction stage.

## 3.2 Pre construction (Site Planning) Guidelines

A good transportation system is the one, which is safe for users and facilitates direct, and easy pedestrian and bicycle circulation between the residence and schools, shops, and work places. The design, scale and development plan of neighbourhood should suit such type of safe movement. There should be coordination of land use decisions with existing and planned public transportation services and the needs for non-motorized access. The concerns pertaining to design of such system and the mitigation options have been discussed below.

### 3.2.1 Concerns

#### 3.2.1.1 *Excessive uses of fuel*

People tend to use motorized vehicle even for the short distances because of shortage of time, and unsafe conditions for bicycling. This leads excessive use of fuel.

#### 3.2.1.2 *Danger of accidents*

The danger of accidents in residential areas is very obvious when the roads are not designed properly. The road sections designed without any consideration for footpaths and bicycle tracks result in mixed traffic and accidents. Other consequences of bad transportation system design are traffic congestion and inconvenience to users.

#### 3.2.1.3 *Air and noise pollution*

Air and noise pollution are the results of the inefficient design of the engines in the vehicles and also the close vicinity of heavy traffic. The short distances between roads and buildings increase the effect of pollution on the buildings and users.

### 3.2.2 Mitigation Options

Road design should be done with due consideration for environment, and safety of users. Users here are the road users and the people residing or working near the roads. Elements of transport system altogether should create a controlled sense of place, where the chances of accidents are minimized and pollution could be reduced. Following measures should be adopted for this.

#### *Design with clusters layout instead of the linear development:*

Clusters reduce the long lengths of road and also the vehicular speeds. The parking spaces in cluster development can be provided outside the cluster and building can be protected from heavy vehicular circulation.

*Creation of Calm transportation system:* Create a transport system where traffic will be calm in neighbourhoods and provide a pedestrian and bicycle friendly travel environment. Traffic in residential, school area, park and commercial areas

can be restricted by regulation and even by the narrow road widths in the campus premises.

*Facilities of bicyclists and pedestrians:* Construct pedestrian and bicycle facilities with appropriate amenities (i.e. drinking water fountains, benches, bicycle parking, etc.) to encourage and support the use of bicycles. Bicycle tracks should be covered or shadowed by tree canopy.

*Promotion of public transport:* Enhance High Capacity Transit use through the provision of adequate access for pedestrians and bicycles at bus stops, transit centres, park-and-ride lots and transit stations. Parking spaces near bus stops must be a part of the design. This will encourage the public mode of transportation.

*Promotion of use of less polluting vehicle engine:* Promote the use of the least polluting type of transportation.

Transportation system is dependent on a number of factors, like design of the engine of the vehicles, traffic rules and regulations, etc., but from construction and development point of view, the above-mentioned mitigation options can be incorporated in design in the form of following heads.

- Hierarchy of roads.
- Road geometry and traffic calming
- Traffic Regulations
- Entry and exit points
- Parking norms

### *3.2.2.1 Hierarchy of roads*

The road system should clearly identify the vehicular and pedestrian circulation. The system should be such that the pedestrian may have ease in moving in whole site in both directions without walking on the major traffic streets.

Hierarchy in roads should be adopted to segregate the traffic according to the size, frequency and density of traffic. Following are the norms for the roads of different hierarchy.

*Arterial road:* These roads are meant for intra-urban through traffic. These roads have no frontage access, no standing vehicle and very little cross traffic and minimum roadway intersection spacing 500 m.

*Sub-Arterial Road:* These Roads are meant for intra-urban through traffic with frontage access, no standing vehicles having high cross traffic, high capacity intersections and minimum roadway intersection spacing 300 m.

*Collector Street:* These are the Streets for collecting and distributing traffic from and to local streets and also for providing access but no parked vehicles and having heavy cross traffic and minimum roadway intersection traffic spacing 150 m.

*Local Street:* Street for access to residence, business or other abutting property, having necessary parking and pedestrian movement.

The Considerations given in Table 3.1 should be incorporated in design to adopt the above-mentioned hierarchy.

Table 3.1: Design considerations for Roads of different Hierarchy

S. No.	Type of Road	Design Speed	Right of way
1	Arterial	80 kph	50-60m
2	Sub-arterial	60 kph	30-40 m
3	Collector street	50 kph	20- 30 m
4	Local Street	30 kph	10-20 m

Source UDPMI guidelines volume i august 1996

The Carriageway widths for the different lane widths will vary. Minimum standard width for single lane road without kerbs should be 3.5 m, for 2-lane without kerb road the carriageway width should be 7.0 m and for 2-lane with kerbs it should be 7.5 m.

Following points should be considered for non-motorized transportation for the cases where the motorized and non-motorized traffic are together.

(i) Footpath/ Sidewalk

Footpaths must be given for safe and easy movement of pedestrians along both the sides of roads. The footpaths should be partly or fully shadowed by trees. Other considerations include width and cross section, materials, lighting and shading, removal of encroachment (hawkers), public toilets and drinking water fountains.

Footpaths should be designed with consideration for restricting hawkers. Some additional space should be provided for hawkers and customers (which can be legally given to a hawkers with nominal rent). Footpath should be made free from hawkers for easy and safe pedestrian movement. The regulation for not allowing hawkers 'shops should be made strict<sup>5</sup>. The space standards for footpath have been given in Table 3.2.

Table 3.2 Space standards for footpath

Capacity (Persons)		Required width of footpath (m)
All in one direction	In both directions	
1220	800	1.5
2400	1600	2.0
3600	2400	2.5
4800	3200	3.0
6000	4000	4.0

Source: UDPMI Guidelines volume 1 August 1996

<sup>5</sup> Although traffic regulations and protection of vulnerable road users is not the part of duty of a developer, but the design of site should be helpful to accommodate the same.

<sup>6</sup> Non-Motorised vehicles in Ten Asian cities, (Washington DC, World Bank), 1995



The width of sidewalk depends upon the expected pedestrian flows and should be fixed with the help of guidelines given by IRC in IRC: 103-1988<sup>7</sup>.

Footpath design should meet with the requirements and standards (guard rail, Gaps/ setback distances, crossings, lighting) given in IRC: 103-1988<sup>8</sup>.

#### (ii) Bicycle track

When the number of motor vehicles using the route is more than 200 per hour, separate, cycle tracks may be justified even if the cycle traffic is only 100 per hour. The space standards for bicycle tracks have been given in Table 3.3. Bicycles and cycle rickshaws' movement should be made safe and comfortable by providing separate tracks, with tough and uniform paving, and easy gradients, and trees. According to IRC: 11-1962, separate cycle track can be provided when the peak hour cycle traffic is 400 or more on routes with a traffic of 100 motor vehicles or more but not more than 200 per hour. For further details of design and layout of cycle tracks, IRC: 11-1962 should be referred<sup>9</sup>.

Table 3.3: Space standards for bicycle tracks

Width of Cycle Track	(m)	Capacity (Cycles/hr)	
		One way	Two Way
Two lanes	3	250-600	50-250
Three lanes	4	7600	250-600
Four lanes	5		>600

Source: UDPFI Guidelines volume 1 August 1996

#### (iii) Foot over Bridges and Subways

The foot over bridges and subways must be a part of footpath design. These should have ramps and accelerators for convenience of senior citizens and people with disability. Over bridges must be provided with adequate vertical clearance as stipulated in IRC: 86-1983.

Norms given in Section 8.4 and 8.5 of IRC: 103-1988, must be followed for design and layout of subway.

#### 3.2.2.2 Geometric Design Improvements for Road Safety

Geometric design of the roads must ensure safety. Some of the crucial elements in geometric design are given below<sup>10</sup>.

Developers must design the system with the standards given with the heading given below.

##### 1. Horizontal alignment (refer section 10 of IRC: 86-1983)

<sup>7</sup> IRC : 103-1998

<sup>8</sup> IRC : 11-1962

<sup>9</sup> IRC : 11-1962

<sup>10</sup> Indian Road Congress Codes

2. Vertical alignment (refer section 11 of IRC: 86-1983)
3. Sight distance (refer section 9 of IRC: 86-1983)
4. Longitudinal section and Cross section (pavement width, shoulder width and type, lane width), roadside design (width, slopes and condition).
5. Medians (refer section 6.2.3 of IRC: 86-1983)
6. Design of intersections, turns and rotaries (refer IRC: 65-1976)
7. Blind corner design with rectified sight distances (refer section 9 of IRC: 86-1983)
8. Reduction of vehicular damage by improving upon road surface pavement (for this refer "Tentative Guidelines on the provision of speed breakers for control of vehicular speeds on the minor roads", IRC: 99-1988)

Apart from this some general points should be considered, these are:

*Visibility over footpaths and Bicycle track:* The landscaping must be done in a way that its elements should not obstruct the visibility as well the movement. Lighting must be adequate for visibility during nighttimes.

*Landscaping of street:* Landscape plan must have consideration for efficient functioning of the road system as well as the physical and visual comfort and aesthetics. Green belt should help to demarcate the automobile highway unite with the one glance. Pedestrian promenade should be covered with shade along the shops. Motorized vehicular lane (MV lanes) can be provided with single or double-sided high foliage trees, which permit the visibility. For pedestrians, a multiple row of trees with very heavy deciduous foliage is required so that the sun rays may pass through in winter. There must be some evergreen trees also with dark and glistening foliage.

*Vertical and Horizontal clearances of overhead electric power and telecommunication lines<sup>11</sup>* - Minimum vertical clearance for different categories of overhead conductor installation should be as under:

- for ordinary wires and lines carrying very low voltage up to and including 110 volts, e.g., telecommunication lines- 5.5 M
- for electric power lines carrying voltage up to and including 650 volts- 6M
- for electrical power lines carrying voltage exceeding 650 volts-6.5 M

Guard cradle or screen should be provided for electrical power lines carrying voltage exceeding 110 volts while crossing the road. The cradle should extend desirably over the full right-of-way. However, guards may be omitted in the case of extra high

---

<sup>11</sup> Notes from IRC : 32 - 1969

voltage lines strung on self-supporting towers designed with adequate safety.

The standards for horizontal clearance laid down above shall not apply to roads situated in hilly areas. In such areas the poles should be erected preferably on the valley side, as far away from the edge of the road as practicable.

Horizontal clearances in respect of poles erected for the purpose of street lighting shall be as under:

- For Roads with raised kerb : Minimum 300 mm from the edge of the raised kerb; 600mm being preferable.
- For roads without raised kerbs: At least 1.5 meter from the edge of the carriageway, subject to minimum of 5.0 meter from the center line of the carriage way.

### 3.2.2.3 Traffic Calming

Traffic calming is a good measure to reduce the vehicular speed and reducing the noise and air pollution and make the system pedestrian and bicyclist friendly. Traffic calming improves the transportation system in terms of visual comfort too. This should be done by the use of physical fixtures such as speed humps and traffic circles to control the speed and movement of vehicles. These measures are effective on the roads passing through universities, hospital zones, residential areas and schools.

The tools of traffic calming are

1. Installation of speed humps by raising the surface of the street in certain spots.
2. Narrowing the street to give drivers the feeling they are in a crowded place, which will make them slow down and totally or partially blocking half the entrance to a side street so drivers cannot turn in but still can come out.
3. Speed tables, build outs, etc.

The Regulations in traffic should be done by Traffic regulation although is a managerial and operational topic, still the considerations for this are required for geometric design.

Enactment of laws is required for

1. Regulation of stopping, standing and parking of vehicles
2. Regulation of traffic by police officers or traffic control devices
3. Regulation of speed
4. Designation of one-way streets, through streets and truck rates
5. Establishment of turn prohibitions and non-passing zones
6. Control of access and improving visibility

Enactment and enforcement of such regulations can enhance urban road safety in a significant manner.

### 3.2.2.4 Entry and Exit point Design

The entry and exit points should be designed in such a way that

1. These should not disturb the existing traffic.
2. There should be adequate provision for parking. Visitors parking should not disturb the traffic of surrounding area.
3. Additional space should be left for the lanes as per the design of existing road, surrounding the site.
4. Bell mouth or arrangement shown in figure 3.1 can be adapted for the safe vehicular movement.

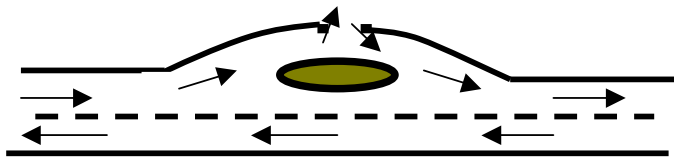

Figure 3.1: Entry and Exit Points

### 3.2.2.5 Parking requirements

Parking requirement is a function of the use pattern of vehicles. The requirements will vary depending upon the type of the city. The ownership of vehicles and use pattern in India is very diverse, but the standards can be derived from some of the sample cities, which are having different character in terms of population. Area requirement for different types of vehicles is given in Table 3.4. According to population size, the cities have been classified into five categories, i.e., less than 50,000, 50,000 to 2,00,000, 2,00,000 to 10,00,00, 10,00,000 to 50,00,000, and above 50,00,000. Parking requirements have been given for these five categories in Annexure 3.1

Table 3.4 Area requirements for different types of parking

Vehicle type	Area required for parking (m)	Clear height (m)
car	2.5x5	2.2
scooter cycle	3x1.4	2.2
trucks	3.75x10	4.75
Parking requirement for per Car space is as per the floor type.		
Basement	35 sqm	
Stilts	30 sqm	
Open	25 sqm	

Source: National Building Code of India

Based on Annexure 3.1, the parking requirement should be calculated for the respective size of the city. This requirement should be compared with the requirement as per the city norms and then the greater one should be implied. For metropolitan

cities, the norms given in Master plan of Delhi 2001 should be followed as Delhi has maximum usage of cars.

Some special provisions should be done for parking and vehicular operation on railway stations and bus terminals. There should be reservation of 80 per cent site area for the operation of transportation system and 20 per cent of site area for buildings in Rail terminals, integrated passenger terminal, metropolitan passenger terminals, bus terminals and depots, inter-state bus terminals and metro yards for car parking. The space standards for car parking should be followed as specified in Table 3.5.

Table 3.5 Space standards for Car Parking

S.No.	Use Premise	Permissible Equivalent Car (:CS) per 100 sq. m. of floor area
1	Residential	2.0
2	Commercial	3.0
3	Manufacturing	2
4	Government	1.8
5	Public and Semi Public facilities	2.0

1. In existing building having plot area of more than 2000 sq. m., extra ground coverage of 5% shall be permissible for construction of automated multilevel parking to provide dedicated parking structures for additional needs.
2. In all premises, parking on the above standards shall be provided within the plot (where the provision exists).
3. Basement(s) up to the setback line maximum equivalent to parking and services requirement, such as installation of electrical and fire fighting equipments, and other services required for the building with prior approval of the concerned agencies, could not be permitted and not to be counted in FAR. However, the area provided for services should not exceed 30% of the basement area. The storage, if provided in the basement, shall be counted in permissible FAR except in the case of residential plot-plotted housing and cluster housing.
4. The side of basement should not project out of the side of the building. The basement(s) beyond the ground coverage shall be kept flushed with the ground and shall be ventilated with mechanical means of ventilation; and
5. Basement(s) shall be designed with due considerations for structural and fire safety.
6. Parking charges should be increased to discourage the use of cars in public spaces.
7. For Multilevel parking following norms must be followed.
  - Multilevel parking facility is to be preferably developed in the designated parking spaces or in the

vacant area, with the following Development control:

- Minimum Plot Size 1000 sqm (However specific proposal, which are technically feasible and viable, could be considered on a cases by case basis for smaller plots by the Authority)
- In addition to the permissible parking spaces (ECS) on max. FAR, 3 times additional space (ECS) has to be provided for parking component only.
- There is no limit for number of basements subject to adequate safety measures.

### 3.3 Guidelines for reduction of pollution during construction and demolition activities

#### 3.3.1 Concerns

The main concerns during demolition and construction activities are the emissions generated by the vehicles and the machineries. The main emissions are the dust, noise and the vibrations, which have been discussed below.

##### *3.3.1.1 Dust and emissions*

The building material carrying vehicles as well as the construction machinery generate emissions and pollute the environment. Dusts include brick and silica dusts, wood dust from joinery and other woodworking and from earthmoving and other vehicle movements within the site. Asbestos-containing dust especially during the demolition of buildings is very harmful. It is a difficult task to separate these particles. In this way, construction machineries pose a special threat to air quality. They emit a toxic cocktail of nearly 40 carcinogenic substances, and are major sources of fine particulate matter (PM<sub>2.5</sub>, which lodges deeply in the human lung) and oxides of nitrogen (NO<sub>x</sub>), a key ingredient in the formation of ground-level ozone and urban smog.

Non-road engines as a class emit more fine particles than the vehicles, trucks. Diesel particles pose the single greatest source of cancer risk from air pollution due to construction machinery. Non-road engines are more polluting than their highway counterparts. Non-road engines remain in use for a very long time, and work on traditional technologies. Since these are very expensive machineries, it is very uneconomical to replace them with machineries with the new machineries with moderate technologies.

##### *3.3.1.2 Noise pollution*

Noise generation disturbs the community residing nearby the site. The main sources of noise in the process of construction and demolition activities are pulverizing, cement concrete mixing, welding, aluminium channel

folding, drilling and several other machineries. The noise level of some of these machineries has been given in Table 3.6.

Table 3.6 Typical noise levels of some point sources<sup>12</sup>

Source	Noise Level dB (A)
Air compressor	95-104
110 KVA diesel generator	95
Lathe Machine	87
Milling Machine	112
Oxy-acetylene cutting	96
Pulveriser	92
Riveting	95
Power operated portable saw	108
Steam Turbine (12,500 kW)	91
Pneumatic Chiseling	118
Trains	96
Trucks	90-100
Car horns	90-105
Jet takeoff	120

### 3.3.1.3 Excessive energy consumption and fuel usage

In the absence of good technologies the fuel usage is going on increasing. The conventional diesel driven machines are huge consumers of fuel and produce smoke as well.

### 3.3.1.4 Vibrations

Vibrations are caused due to heavy dumpers, DG sets, machineries and bulk careers. These affect the forest, vegetation, organisms as well as the structures on the site too. There is a risk of hearing disorder in the workers. The chopping tools with a vibration effect of more than 120 dB (hand-arm), especially the handheld jackhammer might cause "white finger" disease<sup>13</sup>. The surrounding structures may be damaged or show signs like cracks, etc.

### 3.3.1.5 Chemical emissions

Construction and demolition activities generate the emissions of toxic substances too, for example magnesium and limestone dust. There is a risk of fire from the tankers carrying chemicals. Volatile organic compounds (VOCs) from emissions from vehicles, fuel tanks and fuel systems and solvents also possess health risk.

<sup>12</sup> [http://discovery.bits-pilani.ac.in/dlpd/courses/coursecontent/courseMaterial%5Cetzc362%5CNoise\\_Pollution\\_notes.pdf](http://discovery.bits-pilani.ac.in/dlpd/courses/coursecontent/courseMaterial%5Cetzc362%5CNoise_Pollution_notes.pdf)

<sup>13</sup> <http://www.eco-web.com/editorial/010802.html#i>  
White finger disease is a disorder that affects the blood vessels in the fingers, toes, ears, and nose. Its characteristic attacks results from constriction of these blood vessels. Patients initially notice skin discolouration upon cold exposure. They may also experience mild tingling and numbness of fingers or other affected digits that will disappear once the colour returns to normal. When the blood vessel spasms become more sustained, this can cause pain as well as ulceration at the fingertips. Ulcerated fingers or toes can become infected and, with continued lack of oxygen, gangrene may set in.

### 3.3.2 Mitigation Options

The concerns pertaining to the emissions can be minimised by setting up some norms for air and noise quality. Adopting some technologies can do control on the emissions. Following mitigation options have been given for the same.

#### 3.3.2.1 Control of dust

Adopting techniques like, air extraction equipment, and covering scaffolding, hosing down road surfaces and cleaning of vehicles can reduce dust and vapour emissions. Other measures include appropriate containment around bulk storage tanks and materials stores to prevent spillages entering watercourses.

Dust and smoke is a very general problem with the operation of machinery. Construction machinery needs more information about applications of modified machinery, and effectiveness of these applications. There are many examples of construction machinery improvement, such as using ultra low sulphur fuel, retrofits, and early adoption of filter technology, etc.

Construction machineries should be operated with following considerations. The standard limits for this check are given for gasoline driven vehicles and diesel driven vehicles. With effect from 1st April 1996, emission standards are given below:

Pollution under control (PUC) norms of India should be adopted for maintaining the minimum desired quality of air. This check needs to be performed on all vehicles initially one year after its first registration and thereafter once in every six months as per Motor Vehicles Rules, 1989. During PUC test, the following parameters must be measured and assured as per the standards given here:

Gasoline driven 2/3 wheelers: CO < 4.5% by vol., during idling.

Gasoline driven 4 wheelers: CO < 3.0% by vol., during idling.

Diesel driven vehicles: Smoke density < 65% by vol., during both idling & high speed.

For Diesel driven vehicles (Gross vehicle weight < 3500kg and cold start):

CO: 5.0 to 9.0 gm/minute

HC+NOx: 2.0 to 4.0 gm/minute

Smoke density: 65%

The other measures to reduce the air pollution on site are given below.

- Pollution control Check Points should be set up on site.
- On-Road- Inspection should be done for black smoke generating machinery.
- Promotion of use of cleaner Fuel (such as bio-diesel) and Fuel Quality Improvement should be done.
- Inspection should be done for use of covering sheet to prevent dust dispersion at buildings and infrastructure sites, which are being constructed.



- Use of Covering Sheets should be done for trucks to prevent dust dispersion from the trucks, implemented by district offices.

### 3.3.2.2 Control of noise and vibrations

Equipment like earmuffs, earplugs etc. should be used for hearing protection for workers. For Vibration control damped tools must be used and the number of hours that a worker uses them must be limited.

Bureau of Indian Standards (BIS) has published several codebooks for sampling and analysis of noise pollution and guidelines for control of noise pollution. These codes should be referred for noise control and maintaining minimum standards.

- IS-4954-1968 for Noise abatement in town planning recommendations
- IS-3098-1980 for Noise emitted by moving road vehicles, measurement
- IS-10399-1982 for Noise emitted by stationary road vehicles, methods of measurement
- IS-6098-1971 for Air borne noise emitted by rotating electrical machinery
- IS-4758-1968 for Noise emitted by machines

The noise pollution can be controlled at the source of generation itself by employing techniques like Control in the transmission path Installation of barriers etc. Barriers between noise source and receiver can minimize the noise levels. For a barrier to be effective, its lateral width should extend beyond the line-of-sight at least as much as the height (See Fig. 3.2).

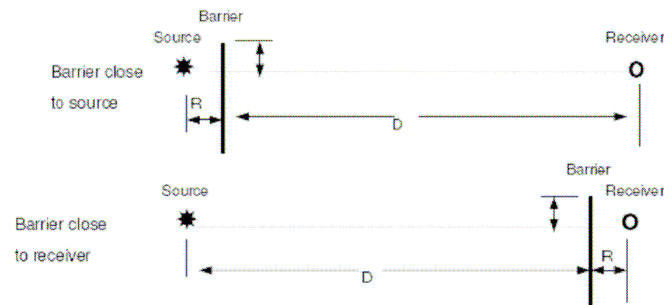

**Figure 3.2: Noise barrier**

R is the distance between source and barrier. D, the lateral width, is the distance between the receiver and barrier. The light horizontal line shows the line of sight. Barrier should be set in such a way that the height of barrier may break the visual contact of the receiver with the source and the audibility is reduced to standard level, i.e., the levels mentioned in codes given above.

### 3.3.2.3 Provision for DG sets<sup>14</sup>

The other norms for DG sets<sup>15</sup> are that the diesel generator sets should be provided with integral acoustic enclosure at the manufacturing stage itself. There must be sufficient space for Fuel Tank inside canopy. There must be enough space to house panel. There must be Strong and Heavy-duty steel base frame for housing D.G. Set. There must be provision for Air-Intake and Air-Exhaust silencer(s) for preventing leakage of sound. There must be a provision of Operable doors for easy access to virtually every part of D.G. Sets . There must be Provision of additional screen and hoods for multi-medium noise suppression.

Noise limits for DG sets- The maximum permissible sound pressure level for new diesel generator (DG) sets with rated capacity upto 1000 KVA, manufactured on or after the 1st July, 2003 shall be 75 dB(A) at 1 metre from the enclosure surface.

The Canopies are must for DG sets and must meet CPCB norms of government of India for noise Pollution effective July 2004 and Environment protection Rules, 1986 schedule 1, by Ministry of Environment Forest.

#### Stack Height :

The minimum height of stack to be provided with each generator set can be worked out using the following formula:

$$H = h + 0.2 \times \sqrt{\text{KVA}}$$

H = Total height of stack in metre

h = Height of the building in metres where the generator set is installed

KVA = Total generator capacity of the set in KVA

Based on the above formula the minimum stack height to be provided with different range of generator sets may be categorised as per Table 3.7:

---

<sup>14</sup> Applicability : These rules shall apply to all new diesel engines for genset applications (hereinafter referred to as 'engine') manufactured in India and all diesel engines for genset applications and diesel gensets (hereinafter referred to as 'product', imported into India, after the effective date. Provided that these rules shall not apply to :

1. any engine manufactured or engine or product imported for the purpose of export outside India , or,
2. any engine or product intended for the purpose of sample only and not for sale outside India.

<sup>15</sup> Standards/Guidelines for control of Noise Pollution from Stationary Diesel Generator (DG) sets by Delhi government.

Table 3.7: Stack Height standards for D.G. Sets

For Generator Sets Total Height of stack in metre	
50 KVA	Ht. of the building + 1.5 metre
50-100 KVA	Ht. of the building + 2.0 metre
100-150 KVA	Ht. of the building + 2.5 metre
150-200 KVA	Ht. of the building + 3.0 metre
200-250 KVA	Ht. of the building + 3.5 metre
250-300 KVA	Ht. of the building + 3.5 metre

The certification of space design for DG sets must be done by any one of the following.

1. Automotive Research Association of India, Pune
2. National Physical Laboratory, New Delhi
3. Naval Science & Technology Laboratory, Visakhapatnam
4. Fluid Control Research Institute, Palghat
5. National Aerospace Laboratory, Bangalore

The norms for emissions from D.G. sets have been given by Central pollution control board, these have been given in Table 3.8

Table 3.8: Emission limits for Noise<sup>16</sup>

Capacity of diesel engines	Date of implementation	Emission Limits G/kw-hr for				Smoke limit (light absorption coefficient, m <sup>-1</sup> )(at full load)	Test cycle	
		NO <sub>2</sub>	HC	CO	PM		%	Factors
Upto 19 KW	1.7.2003	9.2	1.3	5.0	0.6	0.7	100	0.05
	1.7.2004	9.2	1.3	3.5	0.3	0.1	75	0.25
> 19 kw upto 50 kW	1.7.2003	9.2	1.3	5.0	0.5	0.7	50	0.30
	1.7.2004	9.2	1.3	3.5	0.3	0.7	25	0.30
>50kW upto 260 kW	1.7.2003	9.2	1.3	3.5	0.3	0.7	10	0.10
	1.7.2004	9.2	1.3	3.5	0.3	0.7		

Source: CPCB Norms, The Environment (Protection) Second Amendment Rules, 2002, vide notification G.S.R. 371(E), dated 17th May, 2002, at serial no. 94 (paragraph 1 & 3),

<sup>16</sup> The Environment (Protection) Second Amendment Rules, 2002, vide notification no. G.S.R. 371 (E), dated 17<sup>th</sup> May, 2002, at serial no. 95,

### Annexure 3.1 Area requirements for parking in different types of cities

Sl No.	Occupancy	One Car parking Space for Every				
		Populaton less than 50 000	Population between 50 000 to 200 000	Population between 200 000 to 1 000 000	Population between 1 000 000 to 5 000 000	Population above 5 000 000
(1)	(2)	(3)	(4)	(5)	(6)	(7)
i)	Residential			a) 2 tenements having built-up area 101 to 200 m <sup>2</sup>	1 tenement of 100 m <sup>2</sup> built up area	1 tenement of 75 m <sup>2</sup> built up area
a)						
b)	Lodging establishments, tourist homes and hotels, with lodging accommodation	12 guest rooms	8 guest rooms	4 guest rooms	3 guest rooms	2 guest rooms
ii)	Educational			70 m <sup>2</sup> area or fraction thereof of the administrative office area and public service areas	50 m <sup>2</sup> area or fraction thereof of the administrative office area and public service areas	35 m <sup>2</sup> area or fraction thereof of the administrative office area and public service areas
(iii)	Institutional (Medical)	20 beds (Private)	15 beds (Private)	10 beds (Private)	5 beds (Private)	2 beds (Private)
		30 beds (Public)	25 beds (Public)	15 beds (Public)	10 beds (Public)	5 beds (Public)
(iv)	a) Assembly halls, cinema theatres	20 seats	80 seats	25 seats	15 seats	10 seats
	b) Restaurants	60 seats	40 seats	20 seats	10 seats	5 seats
	c) Marriage Halls, community halls	600 m <sup>2</sup> plot area	400 m <sup>2</sup> plot area	200 m <sup>2</sup> plot area	50 m <sup>2</sup> plot area	25 m <sup>2</sup> plot area
	d) Stadia and exhibition center	240 seats	160 seats	50 seats	30 seats	20 seats
v)	Business Offices and firms for private business	300 m <sup>2</sup> area or fraction thereof	200 m <sup>2</sup> area or fraction thereof	100 m <sup>2</sup> or fraction thereof	50 m <sup>2</sup> area or fraction thereof	25 m <sup>2</sup> area or fraction thereof
a)						
b)	Public or semi-public offices	500 m <sup>2</sup> area or fraction thereof	300 m <sup>2</sup> area or fraction thereof	200 m <sup>2</sup> area or fraction thereof	100 m <sup>2</sup> area or fraction thereof	50 m <sup>2</sup> area or fraction thereof
vi)	Mercantile (See Note 2)	300 m <sup>2</sup> area or fraction thereof	200 m <sup>2</sup> area or fraction thereof	100 m <sup>2</sup> area or fraction thereof	50 m <sup>2</sup> area or fraction thereof	25 m <sup>2</sup> area or fraction thereof
vii)	Industrial	400 m <sup>2</sup> area or fraction thereof	300 m <sup>2</sup> area or fraction thereof	200 m <sup>2</sup> area or fraction thereof	100 m <sup>2</sup> area or fraction thereof	50 m <sup>2</sup> area or fraction thereof
viii)	Storage			500 m <sup>2</sup> area or fraction thereof	250 m <sup>2</sup> area or fraction thereof	125 m <sup>2</sup> area or fraction thereof

Source: National Building Code of India

*Notes*

1. In the case of auditoria for educational buildings, parking space shall be provided as per Sl. No. (iv)
2. For plots upto 50 sq. m , as in case of shops, parking spaces need not be insisted upon.
3. For other institutions, transport/communication center, parking space requirement should be assessed based on the proposed building.
4. Not more than 50 % of space in setbacks should be taken up for parking rest under stilts or in basement
5. Minimum width of circulation should be provided for adequate manoeuvring shall be 4m for cars, 5m for trucks.
6. Off street parking should be provided with proper vehicular access. The area for vehicular access shall not be included in the parking area
7. In case of parking in basement at least 2 ramps of adequate size must be provided preferably at the opposite ends.
8. The parking layout should be prepared in such a way that every vehicle becomes directly accessible from circulation driveway
9. For building with different uses parking area required should be calculated on the basis of respective use separately.
10. In case plot containing more than one building parking area should be calculated on the basis of consideration the area of respective uses.

## Reference

1. Indian Road Congress Standards
2. Tiwari G., Urban Transport in India, Transportation Research & Injury Prevention Programme, Indian Institute of technology (IIT), Delhi
3. Sustainable Buildings Guidelines 2003 BBC
4. [www.arbeidstilsynet.no](http://www.arbeidstilsynet.no)
5. Official website of Bhaskar power project India
6. Standards/Guidelines for control of Noise Pollution from Stationary Diesel Generator (DG) Sets by Delhi Government
7. System & Procedure For Compliance With Noise Limits For Diesel Generator Sets (Upto 1000 Kva) by Central Pollution Control Board
8. National Road Transport Policy, India
9. Measures for Controlling Vehicle Emissions in Bangkok, Air Quality and Noise Management Division, Air Quality and Noise Management Division, Department of Environment, Bangkok

10. "Inspection maintenance and certification system for in-use vehicles" an article from Parivesh (newsletter from Central pollution control board India) 2006  
<http://www.bharatpetroleum.com/index.asp>
11. Air Quality and Noise Management Division,  
Department of Environment [www.bma.go.th/anmd](http://www.bma.go.th/anmd)
12. Parivesh: a newsletter from CPCB, India
13. Norms of PUC check by Bharat Petroleum

---

## CHAPTER 4 Building materials and technologies

### 4.0 Introduction

Sustainability and efficiency of a building is largely dependent on the sustainability of building materials. Building industry is dependent on endless supply of high quality materials and energy resources. This can be justified by the fact that buildings on a global scale consume about 40 percent of the raw stone, gravel and sand, 25 percent of wood, 40 percent of energy and 16 percent of the water each year. These result in depletion of non-renewable materials and resources, production of waste by-products, release of pollutants and deterioration of the air, water, soils and the habitat that surrounds it.

The present time demands use of sustainably managed materials. These are the materials that are environmentally preferable and have a mitigated degree of adverse impact on environment and human ecosystem when compared with equivalent products for the same application. Use of sustainably managed materials is an environmental responsibility in contributing towards a sustainable habitat. Their basic characteristics that are required in the present scenario are, ability of natural resource conservation, low embodied energy, potential of recyclability and reuse and low emission levels of toxic substances or pollutant release in each stage of material life cycle.

### 4.1 Scope

The conventional materials and methods of construction are energy intensive in nature. Scope of this chapter covers the selection guidelines for alternate materials and technologies at various stages of building construction. The alternatives for construction of various parts of building have been given in this chapter, i.e., envelope, superstructure, internal paneling roads and surrounding areas.

### 4.2 Issues and concerns

#### 4.2.1 High consumption of resources

Building materials consume huge amount of natural resources in manufacturing and processing. The whole process of manufacture and processing in fact is extractor of various resources at various stages, e.g., resources like energy, water, fuel, and human resources are used in various stages of extraction and processing.

#### 4.2.2 High Transportation Cost

Locally available materials are not used and materials from longer distances are transported. This increases the transportation cost as well as the energy consumption. Use of locally available materials is most suitable to local climate and incurs less transportation cost.

The concern of depleting natural resources indicates the need of using recyclable materials. Use of waste products from other industries in the form of building material is required.

#### 4.2.3 Inefficient technologies and High consumption of materials

Because of inefficient methods of construction the requirement of material goes on increasing. There is thus a need to develop the technologies for construction that require less material and possess high strength.

#### 4.2.4 High life cycle cost of materials

Consumption of natural resources, processing and manufacture, transportation, use in building and maintenance altogether make life cycle cost of conventional materials very high. Some examples are masonry, cement, concrete, timber etc. The materials with low embodied energy<sup>17</sup> and high strength are required as an alternative to the conventional materials. The embodied energies for some conventional materials have been given in Table 4.1.

Table4.1: Embodied energy Content of the materials

Primary energy requirement	Material	Primary energy requirement (Gj/tonne)
Very High Energy	Aluminum	200-250
	Stainless steel	50-100
	Plastic	100+
	Copper	100+
	Steel	30-60
	Lead	25+
High Energy	Glass	12-25
	Cement	5-8
	Plasterboard	8-10
	Lime	3-5
Medium	Clay bricks and tiles	2-7

<sup>17</sup> Embodied energy is the energy consumed by all of the processes associated with the production of a building, from the acquisition of natural resources to product delivery. This includes the mining and manufacturing of materials and equipment, the transport of the materials and the administrative functions. Embodied energy is a significant component of the lifecycle impact of a home.



Primary energy requirement	Material	Primary energy requirement (Gj/tonne)
	Gypsum plaster	1-4
	Concrete	
	In-situ	0.8-1.5
	Blocks	0.8-3.5
	Pre-cast	0.1-5
	Sand, aggregate	<0.5
Low	Fly-ash	<0.5
	Blast furnace slag	<0.5

Source: UNCHS (1991)

#### 4.2.5 Constituents of concern

Some of the facts and figures related to building materials are given below:

- India's fertile topsoil is being destroyed at an alarming rate by the clay brick industry, at 20234 hectares a year. The Indian brick industry, with more than 1 lakh production units producing about 100 billion bricks annually, is the second largest brick producer in the world after that of China. This huge brick manufacturing process is a major consumer of clay, water and fuel.
- The conventional practice of firing clay bricks in Bull's Trench Kilns (BTK) and rural country clamps consumes huge quantity of energy in terms of coal, firewood and other fuels, which are non-renewable and cost high to natural exploitation.
- Brick kilns are also notorious as highly polluting establishments, affecting not just the flora and fauna, but also posing severe threats to human health. The pollution by these units has attracted considerable attention and strict action by the environmental authorities.
- Water requirement of building industry in India is also very intensive.
- India is the second largest cement producing country. In the last decade, installed production capacity of Indian cement industry has increased almost two fold (from 61 to 110 million tonnes / annum). At present, there are large cement plants in the country. Cement dust is generally suspended into air and this suspended particulate matter is harmful for health of the workers.
- The energy requirement of cement industry is very high. In 2003-04, 11,400 million kWh of power was consumed by the Indian cement industry<sup>18</sup>.

<sup>18</sup> [http://www.cseindia.org/programme/industry/cement\\_rating.htm](http://www.cseindia.org/programme/industry/cement_rating.htm) as viewed on Sept. 29, 2006

- Construction of concrete requires a set of form-work, which consists of aluminium, steel, tin or wood, and due to mishandling and wrong practices in use, these forms get damaged. Although these are re-usable components, every year a huge number of new forms are required to fulfil the damages and increasing demand.
- There are about 157 cement manufacturing plants in India. 40 out of 157 operating kilns are based on wet process or semi-dry process of cement manufacturing which puts very negative impact over environment<sup>19</sup>.
- Mining is one of the most destructive industries. Limestone mining badly influences land-use patterns and local water regimes. Ambient air quality is polluted by mining industry.
- Blasting causes problems of vibrations cracks and flies rocks. The impact of mining is especially high in ecologically sensitive areas.
- India faces problems of poor mine management and poor planning for rehabilitation of exhausted land. Mining is one of the reasons for the high environmental impact of the industry<sup>20</sup>.
- Steel is manufactured by non-renewable resource. Its frequent use puts regular pressure on even the kilns, which are flamed by coal, or electricity, which are again non-renewable sources of energy.
- Conventional Materials used for construction of openings are non renewable. Even the constituents of these materials are not renewable.

### 4.3 Mitigation options

Mitigation options are given for each component of the building, i.e., envelope, superstructure, finishes and the road and surrounding areas. The options are given for alternatives of materials and technological options in the order of structure as shown in figure 4.1

---

<sup>19</sup> [http://www.cseindia.org/programme/industry/cement\\_rating.htm](http://www.cseindia.org/programme/industry/cement_rating.htm) as viewed on Sept. 29, 2006

<sup>20</sup> CSE Cement industry ratings releases.htm

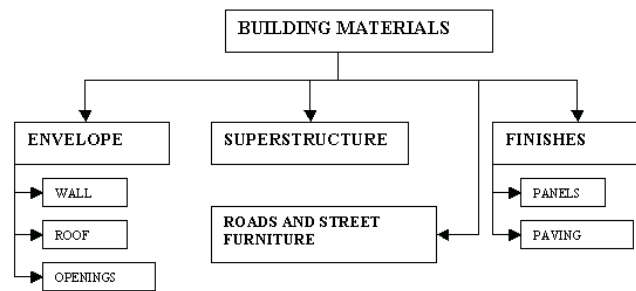

**Figure 4.1 Mitigation options for building materials**

### 4.3.1 Envelope

The alternative options for envelope are given under three headings, i.e., walls, roof and the openings.

#### 4.3.1.1 Walls

The conventional materials used for walling are the clay bricks with cement mortar. The following substitutes should be considered as alternate to bricks.

#### *Alternate Materials for Walls*

1. *Earth blocks*- Earth blocks stabilized with 5%–15% of cement are good choice for low cost, low-rise construction in hot-humid climates. Brick and block products with waste and recycled contents such as fly ash (waste from coal burning plants), blast furnace slag, sewage sludge, waste wood fibre, rice husk ash, etc. Concrete blocks using lime or waste wood fiber provide reduction of waste and saves energy. Fly ash can be used to replace about 15% to 35% of the total cementitious material. The slag content can be used to replace the same between 20% and 25%. Concrete masonry units with finished faces can be used for interior or exterior surface of a wall, in order to reduce the whole layers of additional material. For energy efficiency and comfort, the best practice is to locate the CMU (concrete masonry unit) on the inside and the insulating finish on the exterior. Concrete blocks are also made from sintered clays, PFA (pulverized fuel ash) and lime, which sinter the waste product using the residual fuel in the waste, and thus have a very low embodied energy content.
2. *Fly ash-based lightweight aerated concrete blocks*- Fly ash is a waste product of thermal power plant. Fly ash-based lightweight aerated concrete blocks are manufactured for walling and roofing purposes by mixing fly ash, quick lime, or cement and gypsum with a foaming agent like aluminium powder. These are considered excellent products for walling blocks.
3. *Fal-G (Fly ash, lime, and gypsum)*- Fal-G products are manufactured by binding fly ash, lime, and calcined

gypsum (a by-product of phosphogypsum or natural gypsum). They can be used as a cementitious material for mortar/plasters and for masonry blocks of any desired strength. Fal-G stabilized mud blocks are stronger with less water absorption capacity and are cheaper than cement stabilized blocks. With 5-10% of Fal- G, 30% of cement can be saved in addition to the utilization of waste products like fly ash. These blocks can be manufactured at any low level where good quality burnt clay bricks are not available.

4. *Perforated brick masonry*- Perforated brick masonry is a good option for material reduction. Hollow brick units with perforations up to 50%–60%, are sound in structure and as well as heat insulators. . Various types of perforated bricks used in construction are shown in Figure 4.2. The method of construction is the same as the solid bricks, but this type of brick offers high compressive strength, and low water absorption. These bricks save clay, dry faster, and require less fuel for burning.

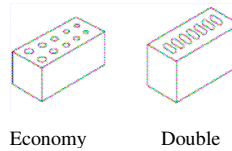

**Figure 4.2 Perforated brick masonry**

*Precast hollow concrete blocks*- Use of hollow units is a good option for material reduction. These are manufactured by using lean cement concrete mixes and extruded through block-making machines of egg laying or static type. These blocks need lesser cement mortar and enable speedy construction as compared to brick masonry. Some of the standard types are shown in Figure 4.3. The cavity in the blocks provides better thermal insulation and also does not need external/internal plastering. These can be used for walling blocks or as roofing blocks along with inverted precast ‘T’ beams.

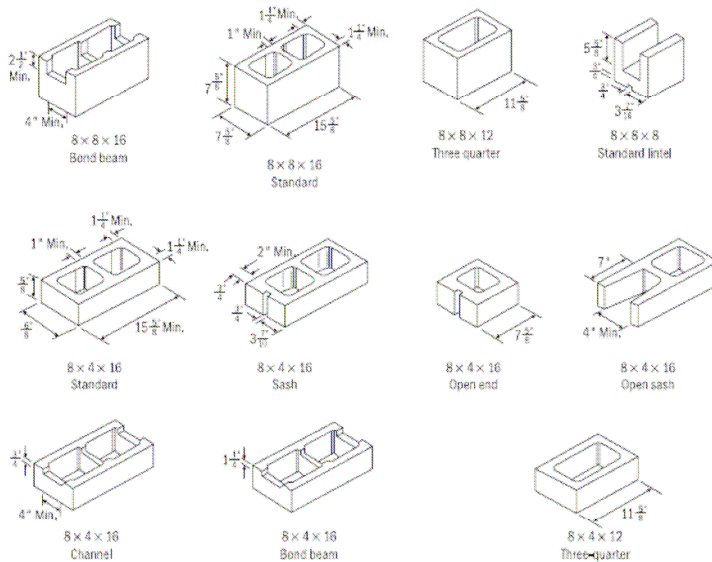

**Figure: 4.3 Standard types of pre-cast hollow concrete blocks**

*Alternate Techniques for Walls*

1. *Hollow/reinforced unit masonry*- Method of construction  
 Hollow unit masonry is the type of wall construction that consists of hollow masonry units set in mortar as they are laid in the wall. All units are laid with full-face mortar beds, with the head or end joints filled solidly with mortar for a distance from the face of the unit not less than the thickness of the longitudinal face. This type of construction can also be reinforced. Bonding where the wall thickness consists of two or more hollow units (Figure 4.4) placed side by side, the stretcher unit must be bonded at vertical intervals, which does not exceed 34 inches (860 mm).

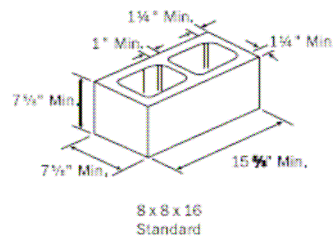
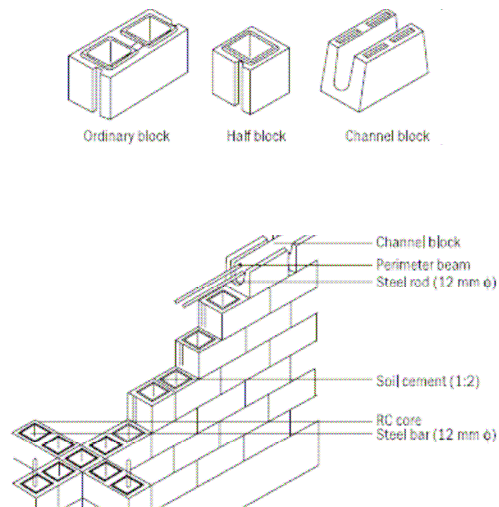

**Fig. 4.4- Hollow / reinforced unit masonry**

This bonding is accomplished by lapping a block at least 4 inches (100 mm) over the unit below or by lapping them at vertical intervals, which do not exceed 17 inches (432 mm), with units that are at least 50% greater in thickness than the units below. They can also be bonded together with corrosion-resistant metal ties as in the cavity walls. Ties in alternate courses should be staggered with 18 inches (460 mm) as the maximum

vertical distance between ties, and 36 inches (90 mm) as the maximum horizontal distance. When this material is not reinforced, the maximum thickness to height ratio is 1:18 with a minimum thickness of eight inches (200 mm).

2. *Some Options for walls:* Some other options for material reduction in walls are 230-mm thick wall in lower floors (load bearing) in place of 330mm brick walls, 180mm thick wall in place of 230mm brick walls, 115mm thick recessed walls in place of 230mm brick walls, 150/200mm stone block masonry in place of random rubble Ashlar masonry etc.
3. *Interlocking concrete blocks or Lock blocks-* The concrete blocks measuring  $298 \times 149 \times 200$  mm have raised rims surrounding two hollow cores on the upper surface, and corresponding recesses on the lower surfaces to receive the projecting rims of the blocks below. The blocks also have narrow vertical recesses and a central hole which, when assembled, form continuous, vertically aligned holes over the full height of the walls. Various types are shown in Figure 4.5.



**Fig. 4.5: Interlocking concrete blocks or Lock blocks**

When cement grout is poured into them, the blocks become permanently locked together. Wherever necessary at the corners, in cross walls or around openings, the large hollow cores, which are always vertically aligned, can be filled with reinforcement and concrete, allowing for building multi-storeys and earthquake resistance. Special blocks like channel blocks are also used to make reinforced concrete beams and triangular blocks for sloping roofs.

4. *Composite ferro-cement system* -This is simple method of construction with ferro-cement, which is actually

made of rich mortar reinforced with chicken and welded wire mesh. This type of construction reduces the wall thickness and thus increase the carpet area. Precast ferro-cement units in a trough shape are integrated with RCC columns. Ferro-cement units serve as a permanent skin unit and as a diagonal strut between columns. The inside cladding can be done with mud blocks or any locally viable material. The details of the system are given in following Figure 4.6. The advantages of the ferro-cement wall over traditional techniques are:

- Self weight is only about 10% of that of a five-inch (125 mm) thick brick wall
- It can be used as an external wall to resist the soaking of facades by rainwater.
- It can be effectively used as a partition wall.
- It saves space.
- Plastering is not required and even whitewashing can be avoided.
- Construction procedure is very simple, quick and less skilled labour is required.
- Heavy equipment for centering and shuttering work or sophisticated workmanship is not required.
- Cheaper than that of a five-inch (125 mm) thick brick
- Savings up to 40%.

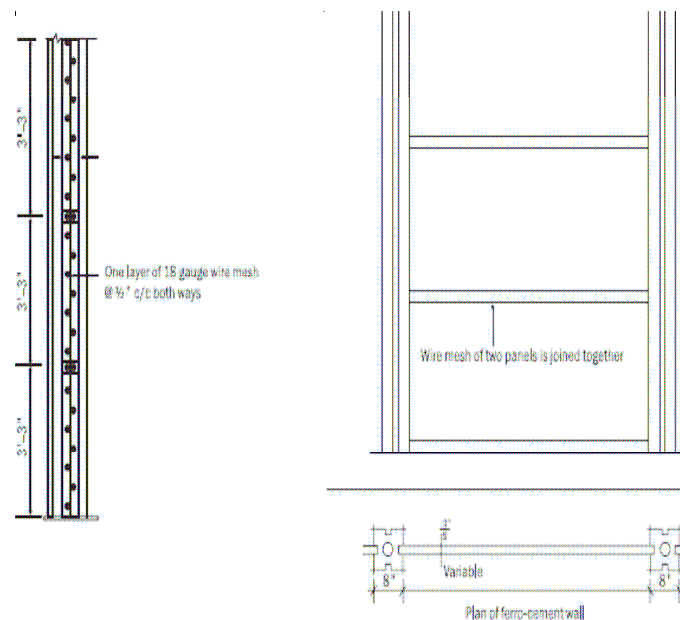

**Fig 4.6: Composite Ferro cement system**

This method is particularly suitable in areas where transport facilities are not available and in hilly areas and also suitable for seismic areas.

5. Rattrap bond in place of English / Flemish bond- The rat-trap bond (Fig.4.7) is an alternative brick bonding system to the English and Flemish bond. This system of bonding saves 25% of the total number of bricks and 40% of mortar. The bricks are placed on the edge in a 1:6 ratio of cement and mortar. After the first layer of bricks has been laid, a gap is left between the bricks within the interior of the wall in the remaining courses. This means that compared to a 230-mm thick solid brick wall, the amount of bricks required to build the wall is reduced by 25% and consequently the amount of cement mortar needed is also reduced.

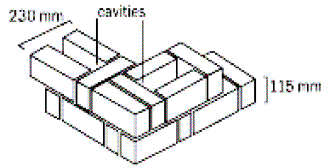

**Fig. 4.7 Rattrap bond**

6. Reinforced/hollow brick masonry- Reinforced/hollow brick masonry is used as structural members for floors, roofs, and walls, and as filler blocks to replace concrete in the tensile zone. The overall dimensions available are  $25 \times 27 \times 10.3$  cm with various configurations of rectangular hollows in it (Figure 4.8). These blocks are also designed separately as bond beams, joist members as well as filler blocks. The reinforcement is placed in the hollows and concreting is done over the brick. The maximum thickness to height ratio is 1:25, with the minimum thickness being six inches (150 mm). Hollow unit masonry is a type of wall construction that consists of hollow masonry units set in mortar as they are laid in the wall. All units are laid with full-face mortar beds, with the head or end joints filled solidly with mortar. The distance from the face of the unit should not be less than the thickness of the longitudinal face. This type of construction can also be reinforced.

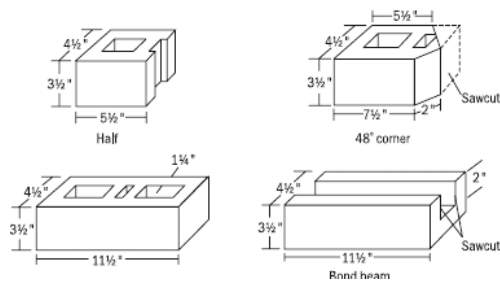

**Fig. 4.8: Reinforced bricks**



7. Hollow unit masonry- All units are laid with full-face mortar beds, with the head or end joints filled solidly with mortar for a distance in from the face of the unit not less than the thickness of the longitudinal face. This type of construction can also be reinforced (Figure 4.9a). They can also be bonded together with corrosion-resistant metal ties as in cavity walls. Ties in alternate courses should be staggered with the maximum vertical distance between ties being 18 inches (460 mm) (Figure 4.9b), while the maximum horizontal distance being 36 inches (915 mm). The floor/roof assembly is a joist and filler block type of construction with cast-in-situ deck concrete over it. To prefabricate the joist member, the top panels of the units are placed in a row one after the other, with a one cm thick 1:3 cement and sand mortar joint on a pre-casting platform to the desired length. The reinforcement is placed within and then filled with concrete of the desired strength.

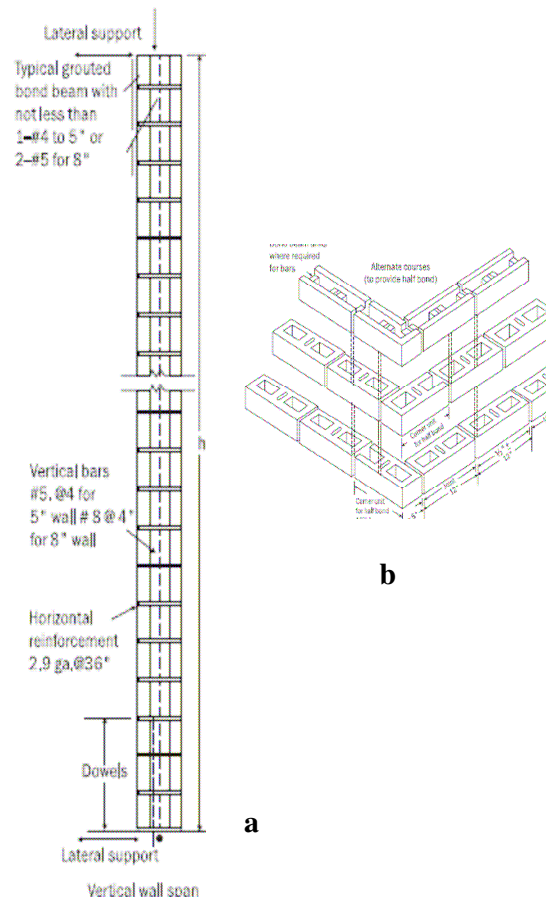

Figure 4.9: Hollow unit masonry

#### 4.3.1.2 Roofing

The conventional material used for roofing is RCC, as it is suitable for longer spans. The constituents of RCC, i.e, cement, sand, aggregate and steel all are energy intensive materials and high-embodied energy content. This section of the chapter gives alternatives is given as a substitute of the conventional materials.

##### *Alternate Materials for roofing*

1. Use of lightweight synthetic aggregate- The example is Fly ash based aggregate, which is suitable for manufacture of brick, blocks, and is good substitute for clinker and natural aggregates.
2. Pre-cast/aerated cellular concrete walling blocks and roofing slabs- These are manufactured by the aerated cellular concrete manufacturing process. When used in multi- storied structures, they reduce the weight, resulting in a more economical design. They have high rating to fire resistance and provide better insulation.

##### *Alternate techniques for roofing*

Construction in concrete put high cost on environment and as it has become a very common practice to use RCC for construction of frames, some alternatives must be used to minimize its use. These are :

1. Zipbloc system- This system developed in India, utilizes a single precast element, a hourdi-type hollow block  $530 \times 250 \times 140$  mm for walls and roofs.

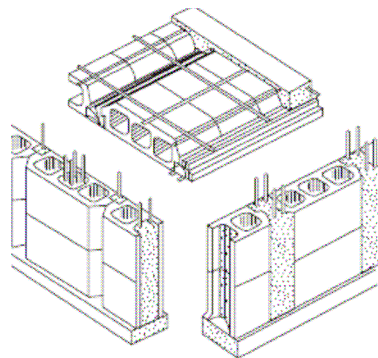

**Figure 4.10. Zip block system**

2. *Pre-stressed slab elements*- This roofing system was developed at the Structural Engineering Research Centre in Chennai. The hollow blocks used are ‘Hourdi’ or similar blocks, and may be placed in one or more rows. Concrete ribs of at least a four-centimetre width

run around the periphery of the row of blocks forming the slab. The prestressing wires are located in these ribs. For units longer than two metres, intermediate ribs with nominal reinforcement are provided in the traverse direction, at spacing that does not exceed two metres. The hollow clay blocks, which have grooves on their surfaces, remain exposed at the top and bottom of the precast element. In situ concrete screed is laid on the top and plastering is done on the underside. The advantage over traditional systems is that the slab elements are about 25% lighter than conventional RCC slabs.

3. *Extruded structural clay joist and filler unit floor/roof-* This roofing system was developed by CBRI (Central Building Research Institute), Roorkee, India. The overall dimensions of the unit are  $165 \times 150 \times 190$  mm as shown in Figure 4.11a. It has three rectangular cavities, which account for 37% of the total volume, and the outer faces have grooves for better bonding of mortar and concrete.

**Prefabrication of joists :** This is done by laying the fired clay units end to end on a flat surface, in a row of the desired length, with the wider base below, and joined with a 1:3 cement and sand mortar. Two wooden planks are placed on either side and held by clamps as shown in Figure 4.11b.

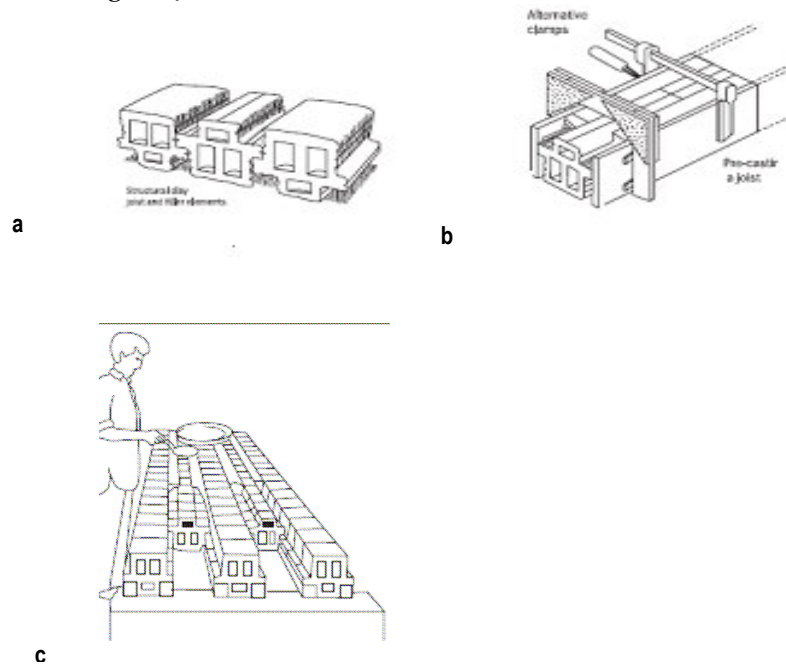
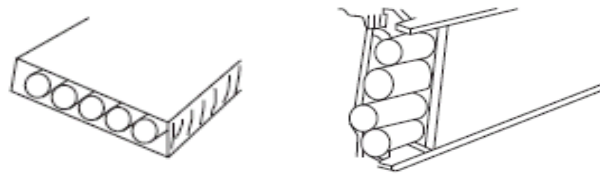

**Figure 4.11 Extruded cultural clay-joist and filter unit floor/roof**

The gap between clay units and planks is filled with concrete, in which the reinforcing rods are embedded,

ensuring good cover from all sides. The joists is manually laid in parallel lines as shown in Figure 4.11c, at distances of 300 mm c/c. The structural clay units, with their wider base below, are laid between the joists as filler units, ensuring that the joints in the joist member and filler units are broken (using half length units at the ends). The joints and gaps are filled with mortar, reinforcement, and concrete. The completed slab is kept wet for 14 days before finishing the floor or roof surface.

4. Hollow floor slabs – This is one more option for material reduction. The overall dimensions of the unit are 3500 × 600 × 120 mm. In this method the steel end-pieces with four openings define a trapezium-shaped cross section of the floor slab, so that when finally assembled, the V-shaped gaps between the slabs can be easily filled with concrete. Reinforcement is laid and four GI pipes are pushed lengthwise (Figure 4.12) through the holes in the end. The concrete is poured and compacted simultaneously to ensure that no air pockets are developed around the pipes. The concrete is cast very dry so that it does not collapse when the pipes are removed. The pipes are later pulled out with an electrical winch as shown in Figure.



**Figure 4.12. Hollow Floor slabs**

5. Precast ferro-cement folded plate-roofing element-  
 Folded plates with a trapezoidal cross-section either in the form of a 'hat' or in the form of a trough section give high rigidity and ensure safety. Such a trough section can be conveniently made of ferro-cement. Roofs made of such trough sections can be constructed by simply assembling such precast FCFP (ferro-cement folded plate) elements side by side on supports (sectional details are given in Figure 4.13), which may be of wall or beam with no in-filling. When required it can be shifted and re-erected as desired. The span length of FCFP element up to 12 feet 6 inches (3810 mm) is adopted for the sake of convenience in handling/hoisting and placing without any mechanical aid. Design of a precast FCFP element (with no diaphragm) may be done as an

inverted T-beam replacing a trough section. The details of FCFP elements are a six-inch (150 mm) base, eight-inch (200mm) depth and thickness of a half to three-quarters of an inch (12-18 mm). Tension reinforcement as per the design requirement is provided and transverse reinforcement is also to be provided in the shape of the profile of the trough section. Skeletal reinforcement of two layers of 24-gauge GI wire mesh at the rate of a half-inch (13mm) c/c with a one-third inch (10mm) cover on either side.

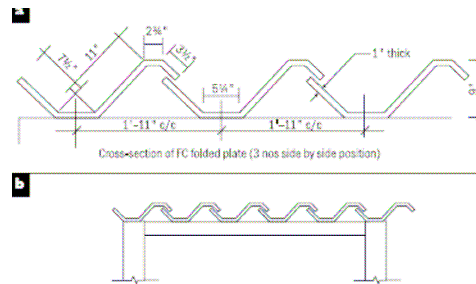

**Figure 4.13. Folded plate Roof**

6. Some other techniques for roofing are
  - Brick panel with joists
  - L-panel sloping roofing
  - Prestressed RCC planks over RCC joists
  - Ferrocement shell roofing
  - Filler Slab roofing
  - Waffle roofing
  - RCC channel units
  - Funicular shell roofing
  - Brick funicular shell roofing
  - Precast blocks over inverted T-beams in place of RCC
  - Tiles over RCC rafters in place of Tiles over timber rafters
  - Micro-concrete roofing tiles in place of Clay tile roofing, AC sheet roofing
  - Fibre Reinforced Polymer Plastics instead of PVC and Foam PVC, Polycarbonates, acrylics & plastics
  - Micro Concrete Roofing Tiles and/or Bamboo Matt Corrugated Roofing Sheet

#### 4.3.1.3 Openings :

The options for openings are given for each individual component, i.e., lintel, frame and panels.

*Alternate materials and Technologies for Lintels :*

The openings consists of lintels, frames and panels. Following options have been given in replacement of conventional PCC lintels.

1. Use of Precast-thin-lintels
2. Ferrocement-sunshades-cum-lintel
3. Brick-on-edge-lintels
4. Corbelling-for-lintels
5. Brick arch for lintels in place of RCC lintel
6. Ferro cement and Pre cast R.C.C. lintel (IS9893)

*Alternate materials for frames of doors and windows*

1. Timber used must be renewable timber from plantations with species having not more than 10 year cycle or timber from a government certified forest / plantation or timber from salvaged wood.
2. Steel with a verified recycled content- The recycled content varies based on the type of furnace used for processing and ranges from 30% (in a BOF [basic oxygen furnace]) to 100% (in an electric arc furnace). Plates, sheets, and tubes are usually manufactured using the BOF. Steel regardless of coating treatments and alloy can be recovered and easily recycled.
3. Aluminium with a verified recycled content- Using recycled aluminium reduces the total energy requirements by 90%–95%. However, only 15%–20% of the aluminium is usually recovered, as it is bound with other materials and is difficult to separate.
4. Scrap components- Salvaged steel and aluminium beam and bar sections made from the recovered scrap for nonstructural uses. Building components such as antique iron and brass fixtures for lighting, decoration, and doorframes can also be reused.
5. Resin or oxychloride cement- bonded, saw dust based door and window frames  
These are made from forest and industrial wastes such as sawdust and wood chips with suitable bonded alternatives and are good substitutes for wood products.

*Alternate technologies for frames of door and windows:*

1. Some combinations- Ferrocement and Precast R.C.C. Frames. (as per IS6523)/ Frameless Doors (IS15345) and/or Bamboo Reinforced Concrete Frames or by hollow recycled steel channels (IS1038,7452) and Recycled Aluminium Channels (IS1948) and Components.
2. Precast RCC doors and window frames- These are cheaper, stronger, fire-resistant, and termite resistant, sustain temperature and humidity variations, and are

effective substitutes to timber/wood. Different frame sizes can be made in adjustable wooden moulds, ensuring at least a 10-mm concrete cover in the finished element. Concrete of grade C15 is used. Provision for fitting grills and fixing of boltholes is also made in the proper position in the frame during casting. Precast door/window frames can be made with ordinary concrete (1:2:4). Precast frames may be used for any conventional cross sections. RC frames for doors/windows are designed and cast separately as horizontal and vertical members to prevent damage/breakage at the time of handling and transportation.

#### *Alternate materials for panels*

The conventional material for panel are plywood, glass and aluminium shutters. Following options have been given for panels :

1. Ferro-cement shutters- These shutters are one-third in cost if compared with even second-grade timber. They can be manufactured on a small-scale level for mass application, and can be painted like timber shutters.
2. Natural fibre-reinforced polymer composite door panels- They are made from plastic components, are cheaper, but look elegant and can compete with wood products.
3. PVC doors and windows- PVC doors, window frame profiles, shutters, and partition panels are made from polymeric building materials using an extruded structural foam polymer made from PVC/ polystyrene and result in a revolutionary synthetic wood. This wood is amenable to carpentry operations, cheaper, provides better thermal and sound insulation, and is non-combustible and maintenance free compared to wood-based products.
4. Medium-density fibre board- This can be used for doors and windows, panelling, ceiling, flooring, partitioning, and built-in furniture.
5. Rice husk board- Doors, partitions, false ceiling boards/ panel, etc. made from rice husk are superior in quality and lower in price compared to products made from wood-based board and are also good substitutes for wood which is a scarce material.
6. Gypsum-based boards- Ceiling tiles, panel blocks, and door and window shutters are manufactured from calcined gypsum obtained by processing photogypsum—an industrial waste of fertilizer plants. Mineral gypsum can also be utilized with suitable processing. Glass fibre or natural fibre-reinforced gypsum panels can also be made. These panels are strong, lightweight, fire-resistant, and provide thermal insulation.

7. **Bamboo Boards:** Bamboo board can be produced after processing split bamboo with machines and glue. These boards can be used for almost all purposes where timber are now used.
8. **Bamboo Mat boards:** Bamboo sliced into slivers and woven, are hot pressed to produce bamboo mat board, which is superior to plywood in strength and life period.
9. **Bamboo Ply boards:** Bamboo mats and slivers are hot pressed to produce bamboo ply board. Bamboo ply board is very strong and as it can be made water resistant, it has applications for construction boards etc.
10. **Bamboo strip boards:** Round bamboo is made flattened either by using special techniques or by applying heat, which is then hot pressed with glue. Bamboo strip boards are used for floors of truck body, railway carriages and container. Unbroken breadth larger than available timber can be achieved with bamboo strip board.
11. **Bamboo particleboards:** Bamboo particleboard, which is bamboo in combination with other cementing materials are also developed and are useful for finishes.

#### *Technologies for panels*

1. **Masonry bond combinations for jali work (achievable in rat trap bond)-** Jali work can be alternatively done using simple masonry bonds such as the rattrap bond. Area such as duct and niches can be covered up using this technique. A high aesthetic value and simplicity of workmanship makes this alternative a preferred choice. Walls and partitions made using this type of bond can also serve as insulating members owing to the cavity formed within. This cavity can be filled with the in-fill type insulation. Being a simple modification of a wall construction, the cost incurred is the same as that of walling units. Moreover, cost of lintels, opening frames and precast or fabricated jalis is completely eliminated.
2. **Energy-efficient windows-** It has been found that the PVC-based window frames provide more energy efficient windows. PVC being a poor heat conductor offers better thermal insulation as compared to aluminium or steel. The design of these windows is such that suitable gaskets in the frames remove the air gap between the window and the wall. These gaskets also reduce noise considerably.
3. **Some other options for Shutters-** Ferro cement door shutters, Use of MDF Board (IS12406), Rubber wood (LSL, LVL), poplar wood, red-mud polymer composite. Use of any of the following individually or in combination can be done for construction of shutters.
  - Red Mud based Composite door shutters,
  - Laminated Hollow Composite Shutters,



- Fibre Reinforced Polymer Board,
- Coir Composite Board (Medium Density IS 15491),
- Bamboo Mat Board ( IS 13958),
- Bamboo mat Veneer Composite (IS 14588),
- Bagasse Board,
- Finger Jointed Plantation Board,
- Recycled Laminated Tube Board
- Aluminium Foil+ Paper+ Plastic Composite Board.

#### 4.3.2 Options for Superstructure

Structural frame of building comprises of footing, columns, beams and lintels, over which the envelope of building is supported. These members take total weight of the building envelopes. Load over structural members is a combination of dead load and live load. In multi-storeyed buildings the dead load of building is more than the live load, so to reduce this load, lightweight materials and some other techniques are required. Some alternatives are given here.

##### *Alternate Materials for superstructure*

1. Ferro cement- The composite Ferro cement system is simple to construct and is made of Ferro cement—a rich mortar reinforced with chicken or/and welded wire mesh. These reduce the wall thickness and allow a larger carpet area. Pre-cast Ferro cement units have a trough shape and are integrated with RCC columns. They serve as a permanent skin unit and as a diagonal strut between columns. The inside cladding can be done with mud blocks or any locally viable material. Ferro cement is suitable for seismic areas.
2. Metals- A variety of metals are used in buildings, but the major building material used structurally is steel. Steel has a high-embodied energy and recyclable content, as well as scrap value. Aluminium forms the second most common material used for roofing sheets, window frames, and cladding systems, which has the highest recyclable content. Other metals such as zinc and lead, which also have recyclable content, are used for roof covering, zinc for galvanizing, and copper for electric cables and so on. Stainless steel and brass products are alloy products that are recyclable, if carefully separated by type. The actual embodied energy costs of the metal products used in building depend on the energy utilized in fabrication and on the waste generated.
3. Use of fly ash and/or blast furnace slag concrete -The amount of cement used in concrete can be reduced by replacing a portion of the cement with coal fly ash (waste material from coal burning power plants) and/or GGBF (ground-granulated blast furnace) slag in conventional mixes. They can be used to replace about 15%–35% of the total cement used and replace up to 70% when used in the

construction of massive walls, dams, road bases, etc. The level of GGBF slag should usually range from 25% to 50%, which constitutes the percentage of fly ash or slag used in concrete. Fly ash provides an excellent finish; however, some types of fly ash often contain high concentrations of natural radioisotopes. The proportions and residual impact of radioactivity should be evaluated and conform to technical standards.

4. Recycled aggregates Recycled aggregates- Crushed concrete, brick, glass, or other masonry waste can also be used in conventional mixes.
5. Lightweight concrete- Aluminium powder when added to lime reacts and form hydrogen bubbles, and a lightweight cementitious material (high strength to weight ratio and an insulation value of R-10 in a 20.32-cm thick wall) is formed which could be used in conventional mixes.

#### *Alternate Techniques for Superstructure*

With the combination of the materials given above the structural system of the building can be altered. Another criterion for material reduction is applicable to formwork and an alternative is suggested below.

Slip - Form- The technique serves a number of forms in concreting of high-rise buildings The basic elements of the formwork are the two sides made of timber planks, plywood boards with adequate bracing, vertical posts 50–70 cm apart held together on top and below with transverse ties of wood or rope, wooden spacers to keep the sides apart at the desired distance, and an end board to close off the open side of the formwork. The length of the formwork can vary between 150 cm and 300 cm, and the height between 50 cm and 100 cm. Formwork is normally moved horizontally after each section is completed. The details for climbing formwork are shown in Figure 4.14 (a and b).

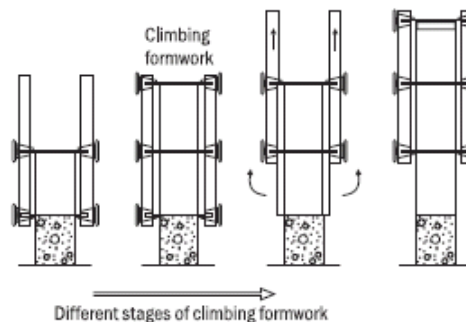

**Figure 4.14 (a): Section showing slip form for columns**

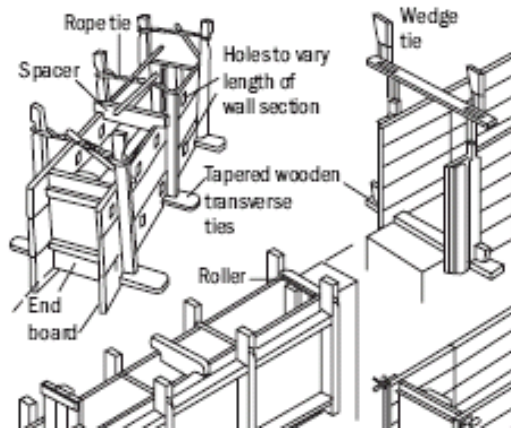

**Figure 4.14 (b): Slip form for beams**

#### 4.3.3 Alternatives for Finishes

1. Fly ash / industrial waste / pulverized debris blocks in BPC and/or lime-pozzolana concrete paving blocks (as per IS10359) to be used for all outdoor paving (as per IS7245).
2. Bedding sand for pavement and outdoor hard surfaces has to be from pulverized debris.
3. Terrazzo floor for terraces and semi covered areas (IS2114) .
4. Ceramic tiles (non-vitrified)(IS 13712)/ Mosaic Tiles/ Terrazzo Flooring (IS2114)/ Cement Tiles (IS1237, 3801)/ Phospho-Gypsum Tiles (IS12679)/ Bamboo Board Flooring, individually or in combination for interior spaces.

#### 4.3.4 Alternatives for roads and open spaces

This part of housing units consists of compound walls, grills, roads, sidewalks, parking lots, drains, curbs, landscaped areas, street furniture, tree covers, flowerbeds etc., although these are not the part of building, but a very necessary part of housing.

1. Permeable paving- Permeable (porous) paving should be used to control surface water runoff by allowing storm water to infiltrate the soil and return to the ground water. Permeable paving includes methods for using porous materials in locations that would otherwise be covered with impermeable materials (parking areas, walkways, and walkways and patio areas). These materials include:
  - Permeable pavers- Paving stones placed in an interlocking fashion over pedestrian surfaces (such as walkways and patios).
  - Gravel/crusher fines- Loose aggregate material used to cover pedestrian surfaces.
  - Open cell pavers- Concrete or plastic grids with voids that are filled with a reinforced vegetative turf or an aggregate material (sand, gravel, crusher fines). These are applicable to limited- vehicle-use areas.

- Porous asphalt (bituminous concrete)- A porous asphalt layer constructed with “open- graded” aggregate (small fines removed), which leaves voids between the large particles unfilled by smaller fine. An open graded stone base holds water until it filters through into the underlying soil. This will be applicable to general-vehicle-use areas.
  - Porous Concrete- A concrete mix without the fine aggregate, and with special additives for strength. Permeable paving is not intended to replace standard impervious paving, but to limit the use of impermeable paving to heavy traffic areas. The availability of recycled content, salvaged materials, and locally manufactured products depends on the specific techniques implemented.
2. Use of grass pavers- Use of grass pavers on the road, parking and pedestrian areas is a solution to reduce the heat island effect. The proposed grass pavers not only help in reducing heat island effect but also minimize storm water runoff and are beneficial for localized aquifer recharge. Grass pavers are perforated material that sits on gravel bed, positioned under the grass surface, they distribute loads from pedestrian and vehicular traffic to the base course below.
  3. Use of Bamboo in Road construction- Bamboo has been used for road reinforcements in Orissa, which has proved its credibility.
  4. Use of bamboo fence instead of steel grills- Use of steel in fencing, grills, tree covers, and benches and even in streetlights can be easily replaced by bamboo. Bamboo is a versatile material, very fast growing variety of trees and can be grown anywhere.

Reference :

Sustainable Building Design Manual, Volume 2,TERI

### 5.0 Introduction

Urbanization and industrialization have resulted in increasing amounts of municipal, industrial, and health care wastes in the country. Waste management in construction industry is very important as it consumes and generates huge quantities of solid waste. According to the materials used and type of construction, the age of building varies from 25 to 100 years. During its whole life span, and even after its use, buildings are the biggest producers of waste, including wastewater and solid waste. Construction waste is bulky and heavy and is mostly unsuitable for disposal by thermal or biological process such as incineration or composting.

Solid wastes from construction sector can be categorized into two phases i.e. during construction & during operation. The construction phase waste will comprise of excavated & demolition material while operational phase waste may comprise of domestic, commercial, biomedical & industrial hazardous wastes, depending upon the type of the project. The different type of wastes need to be handled as per their needs and regulatory requirements. It is not possible to dispose off all type of wastes onto the land and has to be dealt with depending upon their type and characteristics. The growing population in the country and requirement of land for other uses have reduced the availability of land for waste disposal. Re-utilization or recycling is an important strategy for management of such waste.

Building construction leads to generation of sand, gravel, concrete, stone, bricks, wood, metal, glass, polythene sheets plastic, paper etc. as waste. Management of waste during construction and demolition of buildings is a great challenge for planners and urban managers in India.

Central Pollution Control Board has estimated current quantum of solid waste generation in India to the tune of 48 million tons per annum, out of which 25% of waste accounts for construction industry. Management of such high quantum of waste puts enormous pressure on solid waste management system.

Wastes produced by building construction industry are given in table 5.1

Table 5.1: Wastes produced by building construction industry

S. no.	Constituent	Quantity of waste generated (tonnes per anum)
1	Soil, sand and Gravel	4.20 to 5.14
2.	Bricks and Masonry	3.60 to 4.40
3.	Concrete	2.40 to 3.67
4.	Metals	0.60 to 0.73
5.	Bitumen	0.25 to 0.30
6.	Wood	0.25 to 0.30
7	Others	0.10 to 0.15

Source: <http://www.tifac.org.in/offer/tlbo/rep/TMS150.htm>

This data reveals the potential for collection and recycling of waste generated from the construction sites. Management in orderly manner is important to improve the recovery of resources from the waste.

## 5.1 Scope

The scope of this chapter covers the management of waste generated at various stages of building construction and operation. Waste generation by buildings is started, even before its construction. The stages of waste generation are, during preparation of site, during construction and during its use. During these stages, the type of wastes, which are generated, can be classified into four categories.

1. Construction or demolition waste, i.e., massive and inert waste
2. Municipal waste, i.e., biodegradable and recyclable waste
3. Hazardous waste,
4. E-waste

In this chapter the guidelines for management have been framed according to these waste types.

## 5.2 Concerns

Various operations during the construction and demolition leads to the varied compositions in the total solid waste stream and affects the site.

### 5.2.1 Topsoil erosion

Debris, waste plastic pieces, and demolition waste laid over the site destroy topsoil. After this, the land remains unfertile for any kind of vegetation. Light materials like polythene bags; plastics can lead to choking of the drains. Timber pieces generated from beams, window frames, doors, partitions and other fittings, which are treated with chemicals, have adverse effect on environment.

### 5.2.2 Emissions from waste

Loading and unloading operations are often carried out in open areas on the site which results in suspension of light materials due to winds. In addition, spillages due to manual and uncontrolled methods can result in losses as well as adverse impacts on the local soil and groundwater. In addition, there is danger of contamination with various hazardous wastes. The dangers of disposal of these wastes might not be immediately obvious, but improper disposal of these wastes can pollute the environment and pose a threat to human health. Along with the demolition activities, the removal of vegetation, levelling of the site also adds to dust and noise pollution. The suspended soil particles and vegetative matter are rich in organic content and can be used in an efficient manner. Use of asbestos in building has a major impact on human health. When asbestos is disturbed or damaged, the fibers are released into the air and represent a potential risk to human health through inhalation. The fibers measure  $>5\mu\text{m}$  long and  $<3\mu\text{m}$  wide, and can penetrate the lungs. Therefore, the main health consequences of exposure to asbestos fibers are associated with the respiratory system<sup>21</sup>.

### 6.2.3 Insufficient collection and segregation

In general, there is tendency to dump the wastes without segregation on the same site. This results in mixing of recyclable, biodegradable and inert wastes, which in turn would lead to partial reduction and consequently bad odour and air-pollution. The soil near waste storage surface is also polluted. Cities of India are yet to develop an efficient system for collection and disposal of solid waste. Table 5.2 presents the data of solid waste management efficiency for major cities of India.

Table 5.2: Garbage Management in Some Cities

City	Garbage Generated (tonne per day)	Garbage Cleared (tonne per day)	Clearing Efficiency (%)
Delhi	3880	2420	62.37
Calcutta	3500	3150	90.00
Bombay	5800	5000	86.20
Bangalore	2130	1800	84.50
Madras	2675	2140	80.00
Lucknow	1500	1000	66.66
Patna	1000	300	30.00
Ahmedabad	1500	1200	80.00
Surat	1250	1000	80.00

Source: [www.indiastat.com](http://www.indiastat.com)

<sup>21</sup> <http://www.voelckerconsultants.co.uk/asbestos/asbestos%20uses.htm>

This table shows that none of these cities has 100 per cent solution for cleaning of the waste. Even the capital city of India is yet unable to clear more than one third of the solid waste generated, i.e., 37.63 per cent in the city.

#### *5.2.4 Lack of onsite treatment*

Generally the onsite treatment of waste is not done. Various methods for reduction and recycling of waste is rarely practiced. Similarly primary treatment of construction waste, i.e., grinding or crushing etc., are also rarely practiced.

#### *Difficult quantification*

It has been very difficult to establish statistics with any degree of confidence because the waste is deposited in a range of places. In addition, the construction waste is often not recorded as a separate waste stream, or it is incorrectly recorded. Generation and composition of construction and demolition waste is very site specific and dependent on issues such as design, location and the previous use of the site. As such, the waste stream over a period can be extremely variable.

### 5.3 Mitigation options

#### 5.3.1 Good practices in construction management

Some good practices in construction facilitate waste reduction, easy collection and segregation as given below.

1. The explosive for blasting and excavation should be stored in a standard container. Hazardous materials must not be stored near surface waters and should be stored near plastic sheeting to prevent leaks and spills. The handling of explosives should be strictly according to the guidelines as prescribed by the Department of Explosives.
2. Delivery of material on site must be done over a durable, impervious and level surface, so that first batch of material does not mix with the site surface. Availability of covered storage should be assured. Mobile and covered storage boxes with easy drawing and filling mechanism can be used, which can be used over a number of sites.
3. Demolished brick masonry and concrete is a good material for filling. Steel from RCC must be carefully segregated and rest of the material should be crushed on site only. Crushed masonry and concrete is even good for manufacture of synthetic aggregate.
4. The recyclable items like metal, plastic should be sent to recyclable industry, and rest of this scrap should be stored in a covered area.
5. Dry processes of construction are effective for reduction of water requirements and even the waste generation.



- Use of Interlocking bricks, pre-cast roofing and wall panels etc. will be suitable for this purpose.
6. Materials, which are durable and do not require frequent maintenance, should be used. Exposed brickwork in hot and dry climate with Class I bricks requires minimum maintenance. Instead of using stone masonry, stone cladding is a better way to minimize the maintenance.
  7. Wherever materials (aggregates, sand, etc.) are more likely to generate fine airborne particles during operations, nominal wetting by water could be practiced. Workers / labour should be given proper air masks and helmets.
  8. Skilled labour and good workmanship is must for judicial utilization of materials and minimizing the waste.
  9. Construction is more of management. Proper estimate of material is a very first measure to minimize the undue wastage.
  10. Contaminated runoff from storage should be captured in ditches or ponds with an oil trap at the outlet. Contaminated plastic sheeting should be packed and disposed off site.
  11. Communities nearby the blasting site should be consulted before deciding blasting timings / durations and they should be informed / evacuated as required with the knowledge of the district collector' office .
  12. Bitumen emulsion should be used wherever feasible. Contractors should be encouraged to heat with kerosene, diesel or gas to gradually substitute fuel wood. Fuel wood usage for heating should be limited to unsound log i.e. dead and fallen trees.
  13. Bitumen should not be applied during strong winds to avoid danger of forest fire. Bitumen emulsion should not be used in rains. No bitumen must be allowed to flow into the side drain. The bitumen drums should be stored in a designated place and not be scattered along the roadside.
  14. Rubbish, debris and bitumen wastes remaining after blacktop works should be cleaned and disposed off in a safe place.
  15. Materials wasted on site should be reused at the same place. For example, use of excavated earth in landscaping, or use of waste pieces of floor tiles in floor of porch or outdoor spaces, or use of remaining pieces of glass from window panes into ventilators, skylights and boundary wall, or reuse of ply and other timber pieces into furniture etc.

(Source : 1 Ecohousing mainstreaming project, science and Technology Park, Pune  
2 Queensland Government (EPA))

These practices suggest the measures for reduction of waste. However, each type of waste needs special attention and specific kind of management, as the wastes from different activities poses different characteristics. The part of waste management, which comes under the domain of builder, is the good building and site design for facilitation of better management of waste, waste management for construction sites and considerations for hazardous and e-waste management in overall process of work. The sections of this chapter deal with four types of waste, i.e., the construction and demolition waste, municipal waste, hazardous waste and e-waste.

## 5.4 Construction and demolition Waste management

The construction and demolition waste includes debris, concrete (often recycled and reused at the site), steel and other metals, pallets, packaging and paper products, fluorescent tubes, wood beams, joists, studs, baseboards, cabinets and cupboards, railings, brick, doors and casings, interior windows, bathroom fixtures, light fixtures, ceiling grid and tile, furnishings, replant trees, shrubs.

### 5.4.1 Waste recycling Plan

Waste and recycling plans should be developed for construction and demolition projects, prior to beginning construction activity. The plans should identify wastes to be generated, and designate handling, recycling and disposal method to be followed.

### 5.4.2 Handling

Handling of waste material requires special precautions such as personal protective equipment and special procedures to prevent the injury. Developers must operate safe methods for waste collection, storage, and disposal operations in a manner to protect the health and safety of personnel, minimize environmental impact and promote material recovery and recycling.

### 5.4.3 Demolition

Orderly deconstruction is the proper measure for reuse of the demolished matter. In contrast to demolition, where buildings are knocked down and materials are either land filled or recycled, deconstruction involves carefully taking apart portions of buildings or removing their contents with the primary goal being reuse. It can be as simple as stripping out cabinetry, fixtures, and windows, or manually taking apart the building frame <sup>22</sup>.

---

<sup>22</sup> <http://www.ciwmb.ca.gov/condemo/>

A detailed estimate of the valuable materials, which are likely to be obtained during demolition process, is required before the demolition work starts. An evaluation should be conducted to determine if hand deconstruction and salvage is an appropriate and cost effective technique for the project.

#### 5.4.4 Waste Segregation

Gross segregation of construction and demolition wastes into roadwork materials, structural building material, salvaged building parts and site clearance wastes is necessary. Additional segregation is required to facilitate reuse/ recycling.

#### 5.4.5 Storage

Adequate provision shall be made for storage of solid waste and for easy access to the dustbins;

- for labours from source to the place of storage, and
- from the place of storage to a collection point specified by the waste collection authority and/or contractor

Three colours of wheeled bins: - dark grey for inert waste, green for wood and ply waste and blue for hazardous waste can be used.

A minimum of 4% of the total site area should be allocated for storage and pre treatment of the waste. This storage area should be covered and the pollutants from the waste should not affect the surrounding.

#### 5.4.6 Access to and from bin storage areas

Wheeled bins should be made access with ramps. To ensure this vehicle access, paths should be paved and at least 1.2 metres wide with a maximum gradient of 1 in 10. The surface of the path shall be smooth, continuous and hardwearing. Ramped kerbs shall be provided where the path meets the highway, and bins shall not have to pass across designated parking spaces. Where collection vehicles have to enter developments, there should be sufficient space on paved roads with turning circles for easy circulation. This ensures the refuse vehicles to enter the vicinity of the site without being prevented from doing so by cars parked close to the entrance. Vehicles should never have to reverse onto or from a highway to make a collection. Roadways used by refuse vehicles must be designed to withstand a laden weight of not less than 28 tonnes.

### 5.5 Guidelines for municipal waste management

The plan should involve the provision of collection and disposal of wastes on site. Planning of a construction project should have due consideration for waste management. Builders are required to keep space reserved for waste storage, collection and treatment in site planning and architectural designs.

### 5.5.1 Collection

Waste, generated by residential buildings is generally from kitchen, paper and dusting. Waste generation can be broadly classified under three categories.

1. Waste generated by building during its maintenance- These waste can further be classified into daily wastes and long term wastes. Dust deposition is very common phenomenon in hot dry climatic zones. Daily some amount of dust is deposited over the floor and furniture surfaces. The long term waste include broken parts of components of building, e.g., glass pieces, electric fixtures like fused bulbs, tube lights, batteries, rotten parts of door window frames, used carpets, and damaged furniture.
2. Waste generated by landscape areas- These wastes include litter, garden trimmings, tree cuttings, mowing etc.
3. Waste generated by users- Domestic wastes food leftovers, vegetable peels, plastic, house sweepings, clothes, ash, etc. commercial waste generally comprises of paper, cardboard, plastic, wastes like batteries, bulbs, tube lights etc.

Three-bin system is a good option for segregation at household level. Storage facilities shall be created and established by taking into account quantities of waste generation in a given area and the population densities. A storage facility shall be so placed that it is accessible to users, within a radius of 25 meter from the source. Local authorities should provide different coloured bins for different categories of waste.

Some of the good practices have been practiced in smaller cities of India. Figure 5.1 and figure 5.2 shows the community participation in Vellore, Tamilnadu



Fig 5.1 Primary collection using bicycles



Fig 5.2 Facilitating source Segregation

### *Quantification of Wastes*

Household level- The collection at the source means the provision of waste collection at household level. This will lead to

waste minimization at the source itself. If the waste is disposed off in separate bins according to its quality, it will lead to a better way to manage it. The capacity of dustbins should be calculated by assuming the following.

- The use period of a building is about 50 year.
- Annual per capita increase in waste generation is 1.33 %<sup>23</sup> .
- Collection period from household is 2 days, and from storage area dustbins is 2 days.

The average quantity and composition of waste in India varies from state to state, and even city to city. Quantities of waste generated in metro cities and composition have been given in Table 5.3 and Table 5.4. Based over this data of the waste generated in metropolitan cities and the general composition of Municipal solid waste. The average size of the space required can be calculated as per the criterion given in the table (Table 5.4). The space requirements in the sites of larger construction are dependent over the quantity of waste generated. Separation and collection of the waste is the responsibility of the local urban bodies. Design of site and the building should facilitate the easy and convenient collection of waste. The wastes from the buildings should be easy to salvage if it is applicable or to send it to recycling industries. This is possible when the disposal from users has been done in separate bins. The capacity of bins can be calculated based on general composition of solid waste, and per capita waste generated by the major cities. The cities, which do not come into these, can be classified under Class I and Class II cities. The capacity of household bins can be calculated accordingly. The average per capita per day waste production of Class I cities in India is 0.4 kg, and Class II cities 0.2 kg .

Table 5.3 : Quantities of municipal and solid wastes, generation in metro cities

City	Municipal Solid Waste (TPD)	Per Capita Waste (Kg/day)
Ahmedabad	1683	0.585
Bangalore	2000	0.484
Bhopal	546	0.514
Bombay	5355	0.436
Calcutta	3692	0.383
Coimbatore	350	0.429
Delhi	4000	0.475
Hyderabad	1566	0.382
Indore	350	0.321
Jaipur	580	0.398
Kanpur	1200	0.640
Kochi	347	0.518

<sup>23</sup> Ref : Solid Waste management in India, TERI

City	Municipal Solid Waste (TPD)	Per Capita Waste (Kg/day)
Lucknow	1010	0.623
Ludhiana	400	0.384
Madras	3124	0.657
Madurai	370	0.392
Nagpur	443	0.273
Patna	330	0.360
Pune	700	0.312
Surat	900	0.600
Vadodara	400	0.389
Varanasi	412	0.400
Visakhapatnam	300	0.400

Abbre. : TPD : Tonne per day.

Source : Management of Municipal Solid Waste, Central Pollution Control Board, MOEF

Table 5.4 Composition of Municipal Solid Waste

Description	Percent by Weight
Vegetable, Leaves	40.15
Grass	3.80
Paper	0.81
Plastic	0.62
Glass/Ceramics	0.44
Metal	0.64
Stones/Ashes	41.81
Miscellaneous	11.73

Source : Management of Municipal Solid Waste, CPCB,MOEF.

Table 5.5 : Space required for waste storage

City	Per capita waste (kg/day)	Space required in lit. for a group of 20 families in the year 2006	Space required in lit. for a group of 20 families in year 2016
Ahmedabad	0.584	104.0	123.4
Bangalore	0.484	86.2	102.3
Bhopal	0.514	91.5	108.6
Bombay	0.436	77.6	92.1
Calcutta	0.383	68.2	80.9
Coimbatore	0.429	76.4	90.6
Delhi	0.475	84.6	100.4
Hyderabad	0.382	68.0	80.7
Indore	0.321	57.1	67.8
Jaipur	0.398	70.8	84.1
Kanpur	0.64	113.9	135.2
Kochi	0.518	92.2	109.4
Lucknow	0.623	110.9	131.6
Ludhiana	0.384	68.4	81.1

City	Per capita waste (kg/day)	Space required in lit. for a group of 20 families in the year 2006	Space required in lit. for a group of 20 families in year 2016
Madras	0.657	116.9	138.8
Madurai	0.392	69.8	82.8
Nagpur	0.273	48.6	57.7
Patna	0.36	64.1	76.1
Pune	0.312	55.5	65.9
Surat	0.6	106.8	126.8
Vadodara	0.389	69.2	82.2
Varanasi	0.4	71.2	84.5
Visakhapatnam	0.4	71.2	84.5

Source: Derived from Table 5.3 and Table 5.4

Similar to the water supply and sanitation system, developer has to assure the availability and sufficiency of local municipal body to collect the waste from the proposed site, as the entire treatment may not be done at the site. Existing landfill or dumping grounds must have capacity to accommodate the waste generated by the proposed site.

### 5.5.2 Storage

Adequate provision shall be made for storage of solid waste.

Adequate means of access shall be provided

- For people in the building to the place of storage
- From the place of storage to a collection point specified by the waste collection authority and/or contractor

Three colours of wheeled bins: - dark grey for non-recyclable waste, green for kitchen food/ compostable garden waste and blue for paper (generally used for flats, schools, offices etc). In addition, boxes must be provided for the collection of other recyclable materials; a green box is used for paper and a black box is used for cans and plastic collections. Individual properties should be allocated a 20-litter bin although for single-family occupancy.

Boxes should have lids. Flats and multi-storeyed buildings should have bulk dustbin type container, with a general guide of one 1100 litre bin being adequate for every 60 units, for smaller blocks The one to five ratio outlined above could be increased or decreased according to the number or properties with greater or less than two bedrooms per unit. The ratio of approx one paper bin to three residual waste bins is only a guide. Waste and Cleansing Section can advise on individual cases.

### 5.5.3 Bin area design and layout

The diagram (Figure 5.3) shows a suggested possible layout for 1100 litter bin and is only to illustrate the practical set out. A minimum clearance of 150mm is required around all sides of

the bins. Design and choice of construction materials for the bin area will depend upon the individual site. The bins should be placed side by side so that residents do not have to squeeze past to access other bins.

All bin storage areas should have: -

- Adequate lighting – natural and / or artificial;
- Good natural ventilation if completely enclosed e.g. high and low level air bricks;
- A smooth, easily cleanable floor e.g. paving or concrete float finished;
- The floor laid to a fall with suitable drainage;
- A suitable enclosure e.g. wooden fencing, brick or bamboo walls: The diagram below shows a typical wall construction.

In addition, bin storage areas for flats and Multi-storeyed buildings should have:-

- A notice showing which properties are entitled to deposit refuse;
- Suitable “bump strips” provided internally on doors and walls to help prevent damage from loaded bins; and
- Double doors with a clear opening of at least 1500mm and a facility to hold doors open during collection.

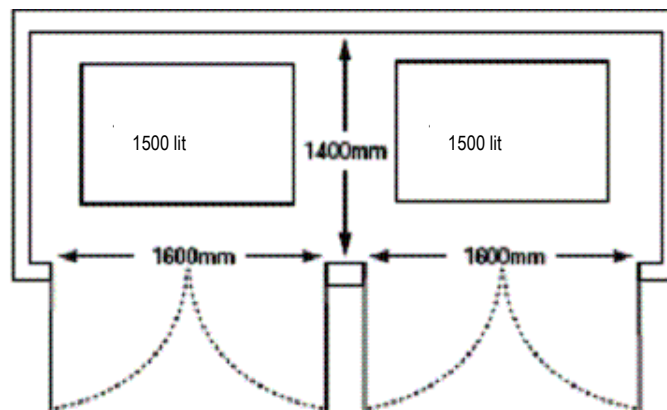

Figure 5.3 : Bin Layout





**Figure 5.4 : An example of Bin Area Storage**

#### 5.5.4 Resource recovery or recycling

Explore the possibility of recycling items that cannot be reused. After storage, the next step in waste management is recycling. The households and users of the new development should be instructed to avoid disposing paper and cardboard wastes along with other organic waste such as vegetable and food waste items. Recycling of these items through the local authorities engaged in these activities should be facilitated. Subsequently provision can be made at the time of design and construction of onsite treatment of waste.

##### *5.5.4.1 Onsite treatment of waste*

Provision for primary treatment over the site is part of site planning, and site plan must include a space for primary treatment of waste. Site plan must include space for biological processing of the vegetable wastes and leafy matter. The biodegradable wastes shall be processed by composting, vermicomposting, anaerobic digestion or any other appropriate biological processing for stabilization of waste.

*Biological processing-* This technique is most appropriate for organic and high-moisture wastes and includes two main processing mechanisms: composting and anaerobic digestion / biomethanation. Composting and anaerobic digestion are techniques that involve the conversion of biodegradable wastes into useful products. This results in the generation of useful resources. Manure or both manure and energy in the form of high-calorific-value fuel

*Compost Facilities-* composting facilities can be established in developments including the communal gardens space in multi-occupation premises for treatment of organic waste as on-site treatment is recognized as the most sustainable method. This should include sites where management contracts are in place and these should use the space for onsite composting of garden

waste. Gardens should be laid out in such a way, that sufficient space has been allowed for home composting.

In the composting process, heterotrophic microorganisms act on the organic matter in the waste. Because of the action of enzymes, the organic compounds are first converted into simpler intermediates like alcohol or organic acids, and later into simple compounds like sugars. Further conversion results in humic acid and available plant nutrients in the form of soluble inorganic minerals like nitrates, sulphates, and phosphates. The steps involved in composting process are shown in figure 5.5.

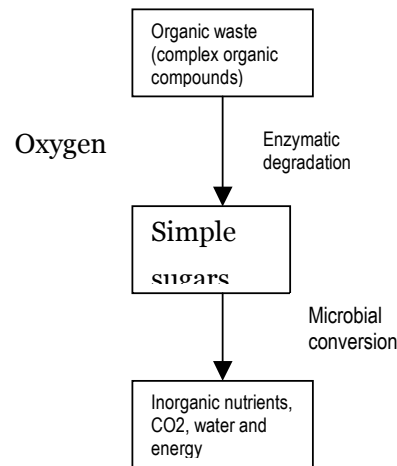

**Figure 5.5 : Steps involved in composting**

Vermicomposting- This is a process where food material and kitchen waste, including vegetable and fruit peels, and papers, can be converted into compost through the natural action of worms. An aerobic condition is created due to exposure of the organic waste to air. Many Asian countries are adopting this process for waste disposal. Although there are thousands of species of earthworm, *Eisenia foetida* and *Eisenia andrei* are widely used for decomposition of organic waste. Certain biochemical changes in the earthworm's intestine result in the excretion of cocoons and undigested food known as vermicastings, which make excellent manure due to the presence of various rich nutrients such as vitamins and enzymes, nitrates, phosphates, and potash. The enzymes produced also facilitate the degradation of various biomolecules present in solid waste into simple compounds for utilization by microorganisms. The innovative collection systems with built-in bins for waste segregation and promotion of home composting in designated areas are being adopted developed countries. (Figure 5.6).



**Figure 5.6 Household Composting Programme**

*Chamber Method* : This method of preparing compost was developed and popularised by Dr. Rekha Saxena of Society for Environment and Development. This is suitable in cities for management of household municipal waste. In this method 8 chambers were constructed above ground in a row (Figure 4). The segregated biodegradable waste was filled in the first chamber for a week. Simultaneously, appropriate quantity of cow-dung slurry was sprinkled over the waste each day, to enhance bio-degradation. After one week the waste collected in the first chamber was transferred manually to the second chamber and the emptied first chamber was ready for fresh waste. Following this process in 8 weeks all the chambers were filled and the waste in the 8th chamber became compost. Under hot tropical climates, the evaporation from waste becomes it dry quickly. Hence water should be sprinkled in each chamber, on the waste to keep it moist so that bio-degradation proceeds smoothly. From here after drying and sieving the compost was ready to use. The size of the chambers depend on the quantity of waste generated and can be increased or decreased. For a block consisting of 500 houses, the land required is approximately 4 m x 9m.

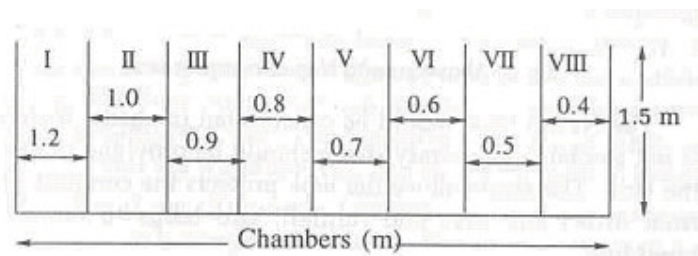

**Figure 5.7 : Chamber method**

Anaerobic digestion - This is a process suitable for food material and kitchen waste, including vegetable and fruit peels. Anaerobic digestion involves the decomposition of organic compounds by microorganisms in absence of oxygen to produce biogas, which is a mixture of methane and carbon dioxide. The optimum temperature for the anaerobic digestion process is

37°C with a pH of 7. In addition to waste treatment, the process of anaerobic degradation is advantageous because of the generation of clean fuel that can be used for various thermal applications and for power generation. The digested sludge can also be used as manure.

*TEAM process for disposal of organic waste* : The TEAM (TERI's enhanced acidification and methanation) technology is a source of fuel for thermal applications, especially cooking in the form of biogas by acting on the Organic solid waste. The system has a series of acidification and methanation bioreactors. In the acidification reactor, the waste bed is kept submerged in water. Organic acids formed as a result of waste degradation lead to the formation of leachate.

Once a high Concentration of organic is extracted in the leachate, which occurs in a retention time of six days, anaerobic degradation of the leachate occurs resulting in biogas. The phase separation provides suitable environment to the micro organisms in acidification and methanation stages, thus enhancing the activity.

The residue inside the acidification reactor is dried in the sun and then used as manure. The microbial consortia present in the anaerobic reactor destroys 90% of the COD, and forms biogas that comprises 70%–75% methane (a high calorific value fuel), carbon dioxide, nitrogen, traces of hydrogen sulphide, and moisture.

The technology will be of great application to municipal corporations and sectors that generate organic waste in large amounts. The biogas produced through this process can be piped and put in use as domestic fuel, and also be used for thermal application.

## 5.6 Hazardous Waste Management

The buildings produce hazardous wastes also. Leftover products from households and offices that contain corrosive, toxic, ignitable, or reactive ingredients are considered "hazardous waste". Products, such as paints, cleaners, oils, batteries, and pesticides that contain potentially hazardous ingredients require special care when you dispose of them. Improper disposal of household hazardous wastes can include pouring them down the drain, on the ground, into storm sewers, or in some cases putting them out with the trash.

Hazardous wastes from construction and demolition activities are centering oil, formwork oil, tar and tar products (bitumen, felt, waterproofing compounds, etc.), wood dust from treated wood, lead containing products, chemical admixtures, sealants, adhesive solvents, Explosives and related products and equipment used in excavation, acrylics, and silica, etc. Many of these when come into direct contact with skin, can cause health hazards. Apart from this, there are many other hazardous wastes; The expected hazardous products, which

need to be disposed off separately is listed below . The dustbins for these wastes should be made of durable materials like metal or even masonry if the projects spans for more than a year.

#### List of Hazardous wastes from construction projects

- Asbestos products<sup>24</sup> – insulation, tiles etc
- Fuels and Heating oils and other volatile / flammable liquids such as coolants, grease etc.
- Centering oil, formwork oil
- Tar and Tar products (bitumen, felt, water proofing compounds<sup>25</sup> etc.)
- Wood Dust
- Lead containing products
- Chemicals<sup>26</sup> , admixtures, sealants, adhesives solvents etc.
- Paints<sup>27</sup> , pigments, dyes and primers<sup>28</sup>
- Carbon black<sup>29</sup>
- Pesticides
- Tarpaulin
- Explosives and related products and equipment used in excavations
- Product packaging (cement bags, cartons, containers, plastic covers etc.)
- Plastics, Acrylics, Silica, PVC
- Fluorescent Lamps Intact and Crushed, Halogen Lamps, Arc Lamps, UV Lamps, High Pressure Sodium Lamps, , Neon Lamps, Incandescent Lamps.
- Mercury Containing Lamps and Tubes, Mercury Vapour Lamps, Mercury Containing Devices – Mercury switches, relays, regulators, thermostats, thermometers, manometers and debris containing mercury<sup>30</sup>
- All types of Batteries
- Electronic Ballasts, PCBs, Transformers, capacitors, switchgear, Lead Cable, Oil filled / gel filled cables
- Electronic Waste– computer products, circuit boards, CRTs, electronic parts, solder dross, weld waste.

---

<sup>24</sup> Asbestos safe Work practices for handling  
[http://www.woksafebc.com/publications/health\\_and\\_safety\\_information/by-topic/assets/pdf/asbestos.pdf](http://www.woksafebc.com/publications/health_and_safety_information/by-topic/assets/pdf/asbestos.pdf)

<sup>25</sup> Dictionary of toxins (<http://www.budgetartmaterials.com/diofto.html>)

<sup>26</sup> Human resources development Canada, occupational safety and health Hand's Off  
(<http://worksafesask.ca/files/hrdc/handsen.htm>)

<sup>27</sup> Paint, Preparation and Existing Paint Safety  
(<http://www.seemydesign.com/livingroom/considerthis/safety/paint.html>)

<sup>28</sup> Dictionary of toxins (<http://www.budgetmaterials.com/diofto.htm>)

<sup>29</sup> Genes, Ethics and Environment – the Ramazzini institute of Occupational and environmental Health Research (<http://www.ramazziniusa.org/sept02/humanecology.htm>)

<sup>30</sup> Medical waste pollution prevention : Keeping mercury out of the wastewater stream  
(<http://www.p2pays.org/ref/01/00790.htm>)

Due to the characteristics, the wastes generated from the healthcare establishments are also hazardous in nature. Biomedical wastes have to be dealt with as per the Biomedical Wastes (Handling & Management) Rules, 2000.

Following guidelines can be followed for handling these.

#### 5.6.1 Collection and storage of hazardous wastes during Pre construction and Post construction

- Lead based paints and other hazardous materials may be removed from the structure prior to deconstruction or demolition activities to minimize special handling and disposal requirements for the construction and demolition waste. These activities must be conducted by qualified personnel using appropriate health and safety procedures in accordance with the regulatory requirements.
- Isolated storage for hazardous wastes released from the whole site should be provided on site.
- Source segregation of similar wastes is highly recommended.
- Installation of fire extinguisher is mandatory near storage of hazardous wastes.

#### 5.6.2 Treatment

Thermal processes of treatment are recommended for hazardous wastes. This method of processing includes direct or indirect burning of waste material, resulting in heat generation through technique such as incineration or plasma gasification. Incineration is more suitable for hazardous waste and requires burning of the waste material at a high temperature of 1000 oC in presence of air.

#### 5.6.3 Disposal

There are some type of wastes which need to be disposed off in the secured landfills. The SLFs should be designed as per the guidelines prescribed by the Central Pollution Control Board. Depending upon the situation, the SLF has to be Single or double liner along with leachate collection & Removal system. The ash generated from the incineration Need to be disposed of in the SLF.

### 5.7 E-waste management

E-waste is one of the fastest growing waste streams around the world today, fuelled by the exponential growth of electronic equipments, especially personal computers and their rapid rate obsolescence. Present estimate shows that, more than 1.38 million PCs are already obsolete in India in both business sector

as well as individual households; and this number is expected to increase further. In India, E-wastes recycling is done mainly in unorganized sector which is emerging as a threat to the environment and health. These wastes contain both precious metals and toxic substances, which if handled properly can result in resource recovery.

#### 5.7.1 Collection and storage

Various types of electrical and electronic wastes generated in the building, which includes PC in case of offices and homes, Xerox machine components from office and shops, should be collected separately for transportation to the authorized recyclers approved by the state/Central pollution control boards. There should also be provision for storage of these wastes in the building before transportation.

#### 5.7.2 Processing of e-waste

The e-waste collected should be processed in authorized recycling unit. The processing steps include

1. Dismantling to isolate the various components containing reusable materials and metals
2. Extraction of metals from individual component through efficient and environment friendly technologies
3. Disposal of waste generated during the processing as per the regulations

### Reference

1. Hazardous Wastes (Management and Handling) Rules, 1989. Department of Environment, Forests and Wildlife, MINISTRY OF ENVIRONMENT AND FORESTS
2. The e-Waste Guide by Indo-German-Swiss Partnership for e-waste.
3. www.indiastat.com, Compendium of Environment Statistics, 2001, Ministry of Statistics, and Programme Implementation, Govt. of India.
4. Asbestos Hazards Handbook - Chapter 4, © 1995 London Hazards Centre, Interchange Studios, Hampstead Town Hall Centre, 213 Haverstock Hill, London NW3 4QP, UK
5. Construction and Demolition Waste management and resource use opportunities July 2002, Queensland Government, Environmental Protection Agency
6. Solid Waste and Emergency, Response (5305W), Washington, DC 20460, EPA530-F-04-008, www.epa.gov/osw
7. Handling and Disposal of Hazardous Materials at Construction Site, 1989, under the provision of the Environment (Protection) Act 1986, by Ministry of environment and forest





## CHAPTER 6 Energy conservation

### 6.1 Introduction

One of the primary requirements of a building is that it should have optimum energy performance and yet would provide the desirable thermal and visual comfort. The three fundamental strategies adopted to optimise energy performance in a building can be broadly classified as:

1. Incorporate solar passive techniques in a building design and enhanced building material specifications to minimise load on conventional systems (heating, cooling, ventilation and lighting)
2. Design energy-efficient lighting and HVAC systems (heating, ventilation and air-conditioning)
3. Use renewable energy systems (solar photovoltaic systems/ solar water heating systems) to meet a part of building load

The primary function of a building is to provide comfortable indoor environment. Traditional buildings of earlier times had built in architectural features that took maximum advantage of climate and its surrounding, which was reflected in the planning and design of the buildings. Modern buildings on the other hand require help of electromechanical devices, which consume enormous amount of energy to provide indoor comfort to the occupants. A growing worldwide concern for the conservation of energy has reawakened interest in ecologically sustainable materials, design strategies that respond to the outdoor climate to achieve comfort conditions inside with minimal dependence upon electromechanical devices. A climate sensitive design approach helps achieve thermal and visual comfort with less dependence upon artificial systems, which results in energy saving with environmental benefits.

This method of achieving thermal and visual comfort with minimum or no use of artificial energy is termed as Solar Passive Architecture.

#### 6.1.2 Scope

This chapter introduces various design concepts, low energy strategies and energy efficient techniques and technologies that could be adopted in various climate zones of India. Simple solar passive techniques such as landscaping, optimum building orientation, arrangement and shape of buildings, effective surface to volume ration, proper location and size of opening, glazing type, shading of windows and judicious selection of building materials are described in this chapter with reference to different climate zones of our country. The chapter covers

the recommendation of the energy conservation building code and the National building code 2005 on energy conservation.

### 6.1.3 Issues of concern

1. In the hot climatic zones of the country, the major concern to achieve comfortable conditions inside buildings, to resist heat gain and promote heat loss through the selection of building materials and design features.
2. In the cold climatic zones of the country, the major concern is to achieve comfortable conditions inside the building, to resist heat losses and promote heat gain.
3. The composite zones of the country, the concern is to resist heat gain in summers and resist heat loss in winters.

### 6.1.4 Recommendations and guidelines for solar passive architecture

The country has been divided into five major climatic zones, the basis of classification is provided in the Table 6.1. The five climatic zones are:

1. Hot and dry
2. Warm and humid
3. Composite
4. Temperate
5. Cold

Table 6.1 Climate zone and their characteristics

Sl. No.	Climate zone	Mean monthly maximum temperature (°C)	Mean monthly relative humidity percentage
i)	Hot-dry	Above 30	Below 55
ii)	Warm-humid	Above 30 Above 25	Above 55 Above 75
iii)	Temperature	Between 25–30	Below 75
iv)	Cold	Below 25	All values
v)	Composite	-	

Source : National Building code, 2005, Part 8

A climate zone that does not have any season for more than six months is classified as composite zone.

#### 6.1.4.1 Building design components

**Building form :** Building form can affect solar access and wind exposure as well as the rate of heat loss or heat gain through the external envelope. Built form and environment share the most complementary relationship in a sustainable design process. The built form in terms of its built mass proportions, density and size, surface to volume ratio and zoning of the built form on site should be modulated as per the wind direction and solar

orientation. A compact building form gains less heat during the day time and loses less heat at night time. The compactness of the building is measured using a ratio of surface area to volume.

$$\text{Compactness} = S/V,$$

where, S = Surface area and V = Compactness

**Orientation :** The amount of solar radiation falling on surfaces of different orientation varies considerably depending on the view or exposure to the sun. Orientation of building façade is an important parameter of solar passive building design. In tropical climates, northward orientation has a very brief period of exposure to solar radiation: early morning and late afternoons on clear summer days. East and west receive maximum solar radiation during the summer months. Southward orientations are exposed to solar radiation during the winter months, which can be potentially used during the cold periods. Orientation also plays an important role with respect to wind direction, especially in the hot and humid climate zones of the country.

#### *6.1.4. 2 Building envelope*

**Opaque surfaces :** Conductivity (K) is defined as the rate of heat flow through a unit of area of unit thickness of the material, by unit temperature difference between the two sides. The unit is W/mK (watt per meter-degree Kelvin). The conductivity value varies from 0.03 W/mK for insulators to 400 W/mK for metals. The lower the conductivity, the better the material is as an insulator. Density is an indicator of conductivity – normally the higher the density, higher will be the K- value. However, this does not hold true for insulation materials. Denser insulation tends to be porous and contains a lot of air, thus keep the conductivity very low (0.026 W/mK).

*Resistance of a surface ( R) = thickness / K – value.*

*Transmittance (U-value) is defined as  $i/R$ .*

The unit is W/m<sup>2</sup>K. Usually, the lower the U-value of the material, the better is the resistance of the material to transfer heat.

**Thermal insulation :** Thermal insulation plays an important role in reducing the U value for the wall section. Insulation is always placed on the hotter side of the surface. In case of summer cooling strategies, insulation is placed on the external side, while in the case of heating the building; insulation should be placed on the internal side. A disadvantage with insulation is that it can prevent the building form to cool down at night.

**Roof :** Roof receives a significant amount of solar radiation; therefore the roof structure plays an important role in providing comfort levels inside the building. In hot climatic zones sometimes the roof is covered by inverted earth pots with a

layer of earth above them. The earth and air inside the pots provide good insulation for resisting heat gains.

**Walls :** Walls constitute a major part of the building envelope and receive a large amount of direct solar radiation. Depending upon the climatic zone and requirement for the building for heating or cooling, wall thickness and composition should be decided. Wall should conform to Table 6.3 ( from ECBC 2006)

**Thermal storage / Thermal Capacity :** Thermal capacity is the measure of the amount of energy required to raise the temperature of a layer of material, it is the product of density multiplied by specific heat and volume of construction layer. The main effect of heat storage within the building structure is to moderate the fluctuation in the indoor temperature profile. The most important aspect to be considered along with the U-value of the building section is thermal storage.

**Solar heat gain factor :** The rate of heat flow through the construction due to radiation is expressed as a percentage of the incident solar radiation is known as solar heat gain factor.

$$SHF (\%) = \frac{\text{transmitted solar energy}}{\text{incident solar energy}} \times 100$$

This is an important criterion for selecting material for areas with intense solar radiation. Roof is one of the major heat gain sources in hot tropical regions. In such climate zones the surface finish should be of high reflective quality, such as light coloured china mosaic tiles.

**Fenestration (Openings) :** Window design forms an important aspect of passive building design. Openings are provided for the purpose of heat gain, ventilation and daylight. Appropriate design of window size, glazing and shading devices help to keep the sun and wind out or allow them inside depending upon the climatic zone and building typology.

Vertical fenestration shall comply with the recommended U-values as well as the maximum solar heat gain factor or Solar heat gain coefficient (SHGC) requirements as given in the Table 6.4 (Source: Energy Conservation Building Code, 2006). In case of windows, the solar heat gain includes directly transmitted solar heat and absorbed solar radiation, which is then reradiated, conducted or convected into the space. The solar heat gain coefficient requirement can be achieved by the selection of glass or selection of glass in combination with shading devices.

**Shading devices :** Shading devices can reduce solar gains through windows. Shading devices that provide significant shading and are permanent in nature could help in reducing the solar heat gain factor (SHGC) through the windows. An

adjusted SHGC, accounting for overhangs and or side fins, is calculated by multiplying the SHGC of the unshaded fenestration product times a multiplication (M) factor. Refer section 6.2.3 to optimise the size of shading devices.

#### *6.1.4.3 Climate zones, comfort requirement and passive design features*

##### 1. Hot and dry climatic zone :

- The main objective is to resist heat gain and promote heat loss. Strategies such as low surface by volume ratio (S/V), increased thermal resistance, increased thermal capacity (time lag), introduction of buffer spaces, decreasing the air exchange during the day time, integration of shading devices and increased surface reflectivity would enable to reduce heat gains inside the building.

Design features which shall enable developers achieve the above defined strategies are: right orientation and shape of the building, selection of the building envelope, integration of design features such as balconies, lobbies, verandas, overhangs, external shading devices, and integration of landscape design and trees around the buildings.

- The second objective in hot and dry regions is to promote heat loss. This could be achieved through ventilation strategies, increased ventilation rates during night time, increasing the humidity levels.

The above defined strategies could be achieved in the building design through appropriate window and exhaust design, integration of courtyards, wind towers in the planning of the building and the humidity levels could be increased through integrating water bodies, evaporative cooling and plantation of trees.

##### 2. Warm and humid region

The passive strategies and design features to achieve comfort is similar to hot and dry climatic zones. The only difference is the requirement to decrease humidity levels and continuous high air exchange rate, ventilation throughout the day is required. To adequately cross ventilate the occupied areas of a house, doors and windows should be provided on both windward and leeward sides of the building. Open planning and wide free spaces between buildings, courtyard planning between buildings would help achieve good ventilation. Ventilation of roof construction would further enhance heat loss through the building structure.

Thus the requirements to be satisfied by the design and construction of a building in warm and wet climate are:

provision of continuous and efficient ventilation, protection from the sun, rain and insects, prevention of internal temperature to rise during day through right building envelope selection and ventilation strategies. In certain months where comfort conditions are impossible, dehumidifiers and desiccant cooling would be desired.

### 3. Moderate regions

- Similar to hot, dry and warm and humid climatic zones, the main objective of the building design is to resist heat gain and promote heat loss. Strategies such as low surface to volume ratio (S/V), increased thermal resistance and increased thermal capacity (time lag), optimised shading and increased surface reflectivity of the external surfaces would help reduce heat gain inside buildings. Design features which enable the developers achieve the above defined strategies are: right orientation and shape of the building, insulation on the roof, east and west orientations, glass surfaces on the east and west orientations should be protected by optimised overhang designs, louvers and trees. External surfaces should be finished in light or pale colours, roof to be finished in glazed china mosaic tiles.
- The second objective is to promote heat loss, which could be achieved through ventilation of appliances and increased air exchange rates. Design features such as correct window design, optimum spacing between building blocks, courtyard planning would enable developers achieve passive strategies into the building design.

### 4. Cold regions

- The main objective of passive building designs in cold regions is to resist heat loss and promote heat gain. Low surface to volume ratio, increased thermal resistance, increased thermal capacity (time lag), increased buffer zones, decrease in air exchange rate and increased surface absorptivity are some of the design strategies that shall enable building designers and developers to resist heat losses from the building. Physical design features that shall enable developers achieve the desired strategies are: right orientation and shape of the building, use of trees to act as wind barriers, use of double glazed windows with weather stripping that shall reduce infiltration of outside air, insulation on the roof and external walls, thick walls to increase thermal capacitance and the external

finish of walls should be dark in colour to increase surface absorptivity.

- The second objective in cold climatic zones is to promote heat gain, which is achieved through maximum exposure of external surfaces to solar radiation, therefore reduce shading over windows. Heat gains from appliances could be utilised to increase internal air temperature. Heat inside the building could also be trapped through incorporation of sun spaces, green houses and trombe walls in the building design.

## 5. Composite region

Composite climate region, the building design should resist heat gain in summers and resist heat loss in winters. And the building should promote heat loss in summer and monsoon months.

Passive strategies and building design features which the developers should consider while designing buildings in the composite climate zones are: low surface to volume ratio, which is obtained through optimised building shape and form, with respect to correct orientation. Increase thermal resistance and thermal capacity which is achieved through insulating roof, walls and designing thick walls. Increase buffer zones to protect the building mass from direct exposure to solar radiation. This is achieved through incorporating verandas and balconies in the design. Decrease outside air exchange rate during day time while increase air exchange rate during night time. Increase shading, by protecting glazed surfaces through overhangs, louvers and trees. Increase external surface reflectivity through selecting light or pale colour finish of the building envelope and finish the roof via glazed china mosaic tiles. In the summer months, increase the humidity, which could be obtained through plantation of trees and water bodies for evaporative cooling. During the monsoon months, if comfort inside the building is not achievable, it is recommended to incorporate dehumidifiers or desiccant cooling in the building.

### *6.1.4.4 Advanced solar passive techniques*

Passive heating : When the temperature outside is lower than inside, heat flows away from a building through its external envelope and by air exchange. The rate of heat loss is determined by building geometry and constructional properties, and by the temperature difference between the inside and outside.

In well-insulated buildings, heat is lost mostly when ventilation by fresh air takes place. Careful consideration should be given to the following:

1. An airtight construction with controllable means of ventilation to minimize unwanted infiltration of outdoor air while providing an adequate supply of fresh air
2. Heat recovery from the outgoing indoor air as a means of reducing the heat deficit imposed by ventilation in the cool period.

Passive solar heating is the spontaneous warming effect resulting from the absorption of solar radiation. The temperature rise this induces leads to heat flow from the affected surface to other surfaces and indoor air, as well as to heat storage within the building structure. Heat storage modulates the excess and deficit in solar gain over the daily cycle, and is a critical design consideration.

The scope for passive solar heating increases with the temperature difference that needs to be bridged between the inside and the outside. However, while maximizing the admission of solar heat into the building, one should keep in mind that this at times may lead to over-heating.

Passive solar heating relies on one or more of the following:

- Windows, clerestories, and skylights; these expose occupied spaces to the sun
- Glazed walls and roofs; these collect and store solar energy without exposing occupied spaces to the sun directly
- Free-running transitional spaces such as conservatories and glazed atria.

*Direct gain method:* Direct gain is a passive heating technique used in cold climates. It is the most common, simple, cheap and effective approach for heating the interiors of a building. Sunlight is permitted into the habitable spaces through an opening to directly strike and heat the floor, walls or other internal objects, which, in turn, heat the air within the room.

Glazed windows are located to face the south (in the northern hemisphere) to receive maximum sunlight in winter. To reduce heat losses during the night these windows are often double-glazed and have insulating curtains.

During the day, the area of the building directly exposed to sunlight tends to over-heat and hence high thermal mass is provided as storage for the heat in the form of bare massive walls or floors to arrest the increase in room temperature.

During the night when night temperature falls, heat stored in the mass is released into the interiors. However care should be taken to see that carpets or curtains do not cover the floor or walls as this prevents heat exchange.

An appropriately designed overhang may be provided to avoid undesired over-heating. In addition to windows, direct gain may be achieved by openings such as clerestories, skylights, greenhouses or glass curtain walls.



Some examples of thermal storage materials are concrete, bricks, stone, and water. The high thermal mass is usually located in the internal or external walls, floors or other built-in structures that receive sun directly.

*Indirect gain* : In this strategy, a thermal storage wall is placed between the glazing and habitable space. This prevents solar radiation from directly entering the living space. It is absorbed by the storage and then indirectly transferred to the habitable space.

*Trombe wall* : A trombe wall is a thick solid wall with vents at its lower and upper ends. This wall is placed directly behind the glazing with an air gap in between. The vents act as inlets of warm air into the room and as outlets for flushing out cool air from the room.

The trombe wall is usually painted black or a dark colour to increase its heat absorptive capacity. The air in the space between the glazing and wall gets heated and enters the habitable room through the upper vents. A natural convection air current is set up when the cool air in the room takes its place through the lower vents.

A part of the heat absorbed by the wall is transferred to the room by conduction and radiation as well. Usually the thickness of the mass wall is between 200 and 450 mm, the air gap is 50–150 mm and the total area of vents is about 1% of the wall area. Water can also be used as a thermal storage material similar to the trombe wall. A water wall can be made up of drums of water stacked up behind the glazing. The external surface needs to be painted black whereas the internal can be any colour. Since storage in the wall is a convective body of mass, heat transfer is more rapid as compared to a masonry wall. Tin cans, bottles, tubes, bins or barrels can also be used to provide different heat exchange surfaces to the storage mass ratio.

*Solar chimneys* : This system is a kind of modified trombe wall that is incorporated into the roof. A solar chimney is essentially a collector panel with minimum thermal inertia on the south face (in the northern hemisphere) of the building. It absorbs incident solar radiation and heats up the air in the air space.

The collector needs to be well insulated to prevent heat loss to the outside. Hot air forces itself into the living space and warms it. Cooler air takes its place and the convection loop repeats itself.

*Sunspaces/solaria* : A sunspace is an integration of direct gain and thermal storage concepts. Solar radiation admitted into the sunspace heats up the air which, by convection and conduction through the mass wall reaches the habitable space. It essentially

consists of a greenhouse constructed on the south side of the building with a thick mass wall linking the two.

**Passive cooling :** Passive cooling systems rely on natural heat sinks to remove heat from a building. They derive cooling directly from evaporation, convection radiation without using any intermediate electrical devices. All passive cooling strategies rely on daily changes in temperature and relative humidity. The applicability of each system depends upon the prevailing climatic conditions.

Relatively simple techniques that could be adopted to provide natural cooling in the building have been elaborated earlier.

These are:

1. Reduction of solar and connective heat import by:
  - orientation of the building
  - shading by adjoining buildings
  - landscaping
  - window-shading devices
  - surface texture and colour
2. Reduction of heat transmission in the building by
  - thermal insulation
  - air cavities

The above-mentioned design strategies reduce heat gains to internal spaces.

This section briefly elaborates passive techniques that aid heat loss from a building by convection, radiation, evaporation or by utilizing the storage capacity of surrounding spaces e.g. earth berming. The passive cooling techniques described are

- Evaporative cooling
- Radiative cooling
- Ground cooling
- Ventilation

**Evaporative cooling : Principle:** Evaporation occurs whenever the vapour pressure of water is higher than the partial pressure of water vapour in the adjacent atmosphere. The phase change of water from liquid to vapour is accompanied by the absorption of a large quantity of sensible heat from the air that lowers the dry bulb temperature of the air while the moisture content of the air is increased.

The evaporative cooling with increase in moisture content of the air is called direct evaporative cooling and when there is no increase of moisture content it is called indirect cooling.

Evaporative cooling lowers indoor air temperatures by evaporating water. It is partially effective in hot, dry climates where the atmospheric humidity is low. In evaporative cooling, the sensible heat of air-cools the living space of the building. The presence of a water body such as pond, lake, or sea near the building or even a fountain in a courtyard can provide a cooling

effect. The most commonly used system is a desert cooler, which comprises water, evaporative pads, a fan and a pump.

Indirect evaporative cooling systems : Roof sprays: External cooling through humidification can be achieved by keeping the surfaces of roofs moist using sprays or a lawn sprinkler. The surface temperature can be reduced significantly, but large amounts of water are used.

Roof pond: A water body covering the roof functions similarly to a soil cover, it minimizes the diurnal temperature range. It is a technically demanding and expensive solution.

Radiative cooling : Principle: Any object emits energy by electromagnetic radiation. If two elements at different temperatures are facing one another, a net radiant heat loss from the hotter element will occur till equilibrium is reached. Any buildings, which see the sky, exchange heat with it. In order to have an appreciable net heat flux between two bodies, the temperature difference should be significant (typically at least 7 °C).

Factors affecting radiative cooling are as follows:

- Temperature difference between the sky and surface. ( $T_{\text{sky}} - T_{\text{surface}}$ )
- Emissivity of the surface
- Emmissivity of sky ( $E = 1$  for clear sky)
- Depends on the sky condition
- Radiative coefficient (function wind velocity)

*Radiative cooling strategies :*

Nocturnal cooling: Night sky cooling can use very low-energy passive systems and can be very effectively used for office buildings, institution, residential buildings.

The heat storage by the envelope can be removed with nocturnal cooling so that the envelope is ready to store the day heat gain.

Roof pond: Movable insulation : A roof pond system with movable insulation is a perfect example of radiative cooling.

In summer : the roof pond is covered with insulation with a surface finish of low absorbtivity. During the daytime, this minimizes the solar radiation impact on the roof, as the water in the pond holds the heat gain and further increase the time lag. During the night the insulation is removed and the heat stored in the daytime is exchanged with the night sky.

In winter: The operation of the movable insulation is reversed to allow heat gain in daytime and reduce heat loss during the night.

Courtyards : Due to incident solar radiation in courtyards, the air gets warmer and rises. Cool air from ground level flows through louvered openings of rooms producing an air flow. At night, the warm roof surface gets cooled by convection and radiation. If that exchange reduces the roof's surface temperature to the wet bulb temperature of air, condensation of atmospheric moisture takes place on roof and that gain due to condensation limits further cooling.

If the roof surfaces slope towards the internal courtyard, the cooled air sinks into the court and enters the living space through low-level openings and leaves through higher level openings.

Temperature depressions of 4 to 7 °C below the ambient can be obtained during clear night-sky conditions.

Limitations : When the courtyard is allowed to receive intense solar radiation, much heat is conducted and radiated into the building.

Intense solar radiation in courtyard also produces immense glare.

Ground cooling : Principle: Throughout the year the earth's temperature below a depth of 2.5 metres remains more or less constant thus offering an important sink for the dissipation of a building's excess heat. Heat dissipation to the ground can be achieved by conduction or by convection.

Ground cooling strategies :

Earth berm structure : Underground structures in contact with the earth are benefited by the huge thermal mass of the adjacent ground and are thus not affected by hot days or chilly nights.

Factors affecting earth berm structures are

- Ground water table
- Daylighting
- Structural stability
- Ventilation

Geothermal cooling or earth-air tunnel systems :

Principle: These work on the principle of conduction and convection. The earth has very stable thermal properties. It has been scientifically proven and validated that temperature at a depth of above 4 m below ground is equal to the annual average temperature of a particular place. This means that on summer days when the outside temperature in some places goes up to 45 °C or goes down to 4 °C in the winter, the temperature at a depth of 4 m depth is constant and equal to the annual average temperature of that place.

Hot summer air is passed through a buried pipe and as it passes through there is an exchange of heat between the air and the

surrounding earth. Hence, during the summer, the air gets cooled up and during the winter it gets heated up. This air is circulated to the living spaces where it takes up the humidity and cools the structure by convection. It works in a similar manner during the winter, picking up the earth's heat and releasing it to the structure.

Factors to be considered in the system design are:

- Depth of the buried pipe below the ground
- Diameter of the pipe
- Material of the pipe
- Length of the pipe
- Wind speed (minimum of 2 m/s)
- Temperature difference between air temperature and ground temperature.

Ventilation :

The ventilation of indoor spaces provides a means to control indoor air quality and achieve thermal comfort. Air movement can provide appropriate air velocities for thermal comfort, even when the temperature and humidity are not the most appropriate.

Where outdoor air conditions allow it, natural conditions may prove to be a way to reduce internal cooling load. Natural ventilation may result from air penetration through a variety of unintentional openings in the building envelope, but it also occurs as a result of manual control of a building's openings (like doors and windows). In both cases, air is driven in and out of the building as a result of pressure difference across the openings, which are due to the combined action of wind and buoyancy-driven forces.

The term natural ventilation is used to describe ventilation processes caused by naturally produced pressure differences due to wind and the stack effect. Natural ventilation is achieved by 'infiltration' and/or by allowing air to flow in and out of a building by openings doors and windows. The term 'infiltration' is used to describe the random flow of air through leakage paths in the building's envelope. The presence of cracks and a variety of unintentional openings, their sizes and distribution determine the leakage characteristics of a building and its potential for air infiltration. The distribution of air leakage paths in a building determines the magnitude of wind-and stack-driven infiltration and the nature of airflow patterns inside the building.

The ventilation of a building can have a significant effect on energy consumption and a thorough assessment of natural as against mechanical ventilation should be made as the decision could significantly affect the energy efficiency of a building.

Ventilation is carried out by one of these two methods:

Stack effect :

Air movement due to the stack effect occurs when temperature differences between a zone and the environment adjacent to it, be it another zone or the exterior, cause light warm air to rise and flow out of the warm zone, while cooler air flows in. The stack effect occurs in tall buildings, particularly in places with vertical passages such as stairwells, elevators, and shafts.

The chimney effect occurs when a density differential is created because of a temperature difference between the interior and the exterior of a building. A higher building temperature causes reduction in the density of air within it and causes it to rise. If there is an opening at a higher level, the hot air exits through it and is replaced by cooler air infiltrating the building through a lower opening. The efficiency of ventilation depends on the temperature difference between the inside and outside, the size of inlets and outlets and height difference between the entry and exit openings. The magnitude of airflow associated with the stack effect and infiltration grows with the temperature difference.

*Wind-induced pressure differences*

Positive pressure is created on the side of the building that faces the wind (windward side) whereas suction regions are formed on the opposite sides (leeward sides) and on the other sidewalls. This results in a negative pressure inside the building, which is sufficient to introduce large flows through the building openings. In general, an inflow of air is induced on the windward side and an outflow on the leeward side.

The action of external wind on the walls of the building may be used to effect ventilation inside.

Wind pressure on a building depends on wind direction, wind speed, and the shape of the building and location of its openings. The size of the inlet and outlet affect internal wind speed and direction in the following manner:

1. Small inlets and large outlets will result in high maximum speed but poor distribution, with large areas of the room experiencing low wind speeds.
2. Large inlets and small outlets will result in lower maximum speeds but better distribution of air movement throughout the room, with only a small area having low speeds.
3. Internal wind speed does not increase significantly when window size is increased beyond 40% of wall area.

Location of openings for ventilation : The proper location of openings is of primary importance in obtaining natural and efficient ventilation.

The following observations have been recorded in wind tunnel studies:

1. Changing the location of the outlet does not affect the airflow pattern in the building.

2. Changing the location of the inlet affects air-flow pattern in the building in the following manner:

Direction of airflow and speed are both dependent on the location of the inlet. Bringing the opening closer to the floor or the ceiling will accordingly divert the flow. It is usually desirable to place the inlet between 1 m and 2 m from the floor to direct airflow towards the heads of the occupants.

3. Overhangs or awnings increase the air velocity through windows below them-  
Roof-level vertical fins may be added to the side of the windows to increase air speed.
4. The configuration of sashes may significantly affect flow of air through opening-

Sashes opening on vertical or horizontal pivots allow reflection and control of air current direction.

A continuous flow of air will be ensured if there are no significant barriers (like walls or internal partitions) between entry and exit openings.

In cross-ventilation, the airflow depends directly on the difference in pressure at the openings. The main parameters influencing airflow levels are:

- Inlet and outlet surfaces of the openings
- Wind velocity and direction
- Temperature difference between the indoor and outdoor environments
- The relative positions of the openings
- The relative wind shadowing of the building

These parameters can be combined in almost infinite ways and therefore it is virtually impossible to classify and present in a simple way results of all possible configurations. However, it is possible to study the impacts of some decisive architectural design parameters under certain urban and climatic conditions.

#### Night ventilation

Daytime ventilation introduces fresh outdoor air, which is necessary in order to maintain acceptable indoor air quality. In addition to these amounts of outdoor air, ventilation can also provide appropriate means for passive cooling, once the outdoor air is at a lower temperature.

Alternatively, ventilation can also continue into the night time, with positive results on reducing the cooling load of the building. During the night, outdoor temperatures are lower than indoor ones. Consequently, it is possible to ventilate the building by allowing the outdoor air to enter the spaces and remove the stored heat that has been trapped during the day. The air movement increases the heat dissipation from the building materials and the warmer air is then exhausted into the low temperature atmospheric heat sink. This process continues during the night and, as a result, the indoor air temperature and mass of the building are at lower levels when the temperature-

increase cycle starts again the following day. Consequently, in the morning, occupants enter a cooler environment, which means that even in air-conditioned buildings, one could have substantial energy savings from the reduced operation of the mechanical system.

Night ventilation of a high mass structure can lower internal temperatures by 7 °C in a hot-dry climate. Even though this temperature is still higher than the comfort range, the difference can be overcome with the use of cross ventilation and ceiling fans. Similarly in hot, humid climates the temperature drop due to night ventilation is 3 °C but can be aided by good cross-ventilation.

### *Ventilation strategies*

#### Chimneys

Chimney or stacks can be used to provide high-level ventilation outlet devices. They work mainly through the stack effect, allowing the warm air at high level in rooms to escape to outside.

Although windows and other openings are key components that induce natural ventilation, there are some additional means of enhancing air movement (e.g wind towers and solar chimneys). Wind towers use the kinetic energy and wind, which is properly channelled into a building to generate air movement within a space. Solar chimneys are constructions used to promote air movement throughout a building using solar gains.

#### Wind towers

Wind towers are generally used in hot and dry climates for cooling. Wind towers operate in many ways depending on the time of day and wind availability. Wind towers work on the principle of changing air density in and around the tower.

During daytime, hot ambient air comes into contact with the cool, top part of the tower and gets cooled. Cool, dense air sinks through the tower and into living spaces (through vents and openings). Increased wind velocity improves the performance of wind towers. During the night the reverse takes place. Cool air comes in contact with the warm inner surface of the tower. This air in turn gets warmed up, rises and is exhausted through openings. The pressure difference thus created pulls the cool night air through the doors and windows into the building.

Due to small storage capacities, sensible cooling may stop after several hours of operation on hot summer days. In order to improve the efficiency of its operation, evaporating cooling is used in conjunction with sensible cooling. Wind towers can bring about a difference of 10–15 °C in arid climates. Wind towers can be combined with ground cooling to give better performance and have been used effectively in several buildings in the Middle East and West Asia.



It may be noted that wind towers are used only for summer cooling. Proper care should be taken to close the vents and openings during the winter.

Building envelope recommendations as per ECBC 2006  
The building envelope for all air conditioned buildings and air conditioned spaces have to comply with prescriptive requirements of Energy conservation building code or with the requirements of the Building envelope trade off option (The building envelope complies with the code if the building envelope performance factor (EPF) of the proposed design is less than the standard design, where the standard design exactly complies with the criteria in 4.1. The envelope trade-off equation is found in Appendix 13 of ECBC (Download from [beeindia@nic.in](mailto:beeindia@nic.in))

## 6.2 Prescriptive requirements

### 6.2.1 Roofs

Roofs shall comply with either the maximum assembly U-factor or the minimum insulation R-value in Table 6.2. R-value is for the insulation alone and does not include building materials or air films. The roof insulation shall not be located on a suspended ceiling with removable ceiling panels.

Table 6.2 Roof assembly U-factor and insulation R-value requirements\*

Climate Zone	24-Hour use buildings Hospitals, Hotels, Call Centers etc.		Daytime use buildings Other Building Types	
	Maximum U-factor of the overall assembly (W/m <sup>2</sup> -°C)	Minimum R-value of insulation alone (m <sup>2</sup> -°C/W)	Maximum U-factor of the overall assembly (W/m <sup>2</sup> -°C)	Minimum R-value of insulation alone (m <sup>2</sup> -°C/W)
Composite	U-0.261	R-3.5	U-0.409	R-2.1
Hot and Dry	U-0.261	R-3.5	U-0.409	R-2.1
Warm and Humid	U-0.261	R-3.5	U-0.409	R-2.1
Moderate	U-0.409	R-2.1	U-0.409	R-2.1
Cold	U-0.261	R-3.5	U-0.409	R-2.1

\*See Appendix 12.3 for typical complying roof constructions

### 6.2.2 Opaque walls

Opaque walls shall comply with either the maximum assembly U-factor or the minimum insulation R-value in Table 6.3. R-value is for the insulation alone and does not include building materials or air films.

Table 6.3: Opaque wall assembly U-factor and insulation R-value requirements

Climate Zone	Hospitals, Hotels, Call Centers (24-Hour)		Other Building Types (Daytime)	
	Maximum U-factor of the overall assembly (W/m2-°C)	Minimum R-value of insulation alone (m2-°C/W)	Maximum U-factor of the overall assembly (W/m2-°C)	Minimum R-value of insulation alone (m2-°C/W)
Composite	U-0.352	R-2.35	U-0.352	R-2.35
Hot and Dry	U-0.369	R-2.20	U-0.352	R-2.35
Warm and Humid	U-0.352	R-2.35	U-0.352	R-2.35
Moderate	U-0.431	R-1.80	U-0.397	R-2.00
Cold	U-0.369	R-2.20	U-0.352	R-2.35

See Appendix 12.4 for typical complying wall constructions

Exception: Until December 31, 2007, the wall assembly U-factor is allowed to be U-0.440 maximum or insulation R-2.10 minimum

### 6.2.3 Vertical fenestration

Vertical fenestration shall comply with the maximum area weighted U-factor and maximum area weighted SHGC requirements of Table 6.4. Vertical fenestration area is limited to a maximum of 40% of the gross wall area for the prescriptive requirement.

Table 6.4: Vertical fenestration U-factor and SHGC requirements

Climate	Maximum U-factor (W/m2-°C)	Maximum SHGC
Composite	3.177	0.25
Hot and Dry	3.177	0.25
Warm and Humid	3.177	0.25
Moderate	6.922	0.40
Cold	4.085	0.51

Exception to Table 6.2.3: Overhangs and/or side fins may be applied in determining the SHGC for the proposed design. An adjusted SHGC, accounting for overhangs and/or sidefins, is calculated by multiplying the SHGC of the unshaded fenestration product times a multiplication (M) factor. If this exception is applied, a separate M Factor shall be determined for each orientation and unique shading condition.

The M factor could be determined by the Projection Factor (PF), which is the ratio of the overhang projection (P) divided by the sum of the height of the fenestration and the distance from the top of the fenestration to the bottom of the farthest point of the external projection in consistent units (H). Thus,  $PF = P/H$

For example: Window on South orientation,

H	=	1200mm,
P	=	900mm
Glass selected has SHGC	=	0.46
PF	=	0.46M
M	=	0.52

Adjusted SHGC = M\*SHGC of glass = 0.52\*0.46 = 0.24

Table 6.5: SHGC "M" factor adjustments for overhangs and fins

Overhang "M" Factors for 4 Projection Factors						Vertical Fin "M" Factors for 4 Projection Factors				Overhang+Fin "M" Factors for 4 Projection Factors			
Project Location	Orientation	0.25–	0.50–	0.75–	1.00	0.25–	0.50–	0.75–	1.00	0.25–	0.50–	0.75	1.00
North	N	.88	.80	.76	.73	.74	.67	.58	.52	.64	.51	.39	.31
latitude 15° or greater	E/W	.79	.65	.56	.50	.80	.72	.65	.60	.60	.39	.24	.16
Less than 15° North latitude	S	.79	.64	.52	.43	.79	.69	.60	.56	.60	.33	.10	.02
	N	.83	.74	.69	.66	.73	.65	.57	.50	.59	.44	.32	.23
	E/W	.80	.67	.59	.53	.80	.72	.63	.58	.61	.41	.26	.16
	S	.78	.62	.55	.50	.74	.65	.57	.50	.53	.30	.12	.04

Exception to SHGC Requirements in Table 6.2.3 :Vertical Fenestration areas located more than 2.2 m (7 ft) above the level of the floor are exempt from the SHGC requirement in Table 6.4, if the following conditions are complied with:

1. Total Effective Aperture: The total Effective Aperture for the elevation is less than 0.25, including all fenestration areas greater than 1.0 m (3 ft) above the floor level; and,
2. An interior light shelf is provided at the bottom of this fenestration area, with an interior projection factor (PF) not less than:
  - i. 1.0 for E-W, SE, SW, NE, and NW orientations
  - ii. 0.5 for S orientation, and
  - iii. 0.35 for N orientation when latitude is < 23 degrees.

**6.2.3.1 Minimum Visible Transmission (VT) of Glazing for Vertical Fenestration**

To permit the use of available day lighting in place of electric lighting, glazing products used in offices, banks, libraries, classrooms with predominant daytime usage, must have the minimum visual transmittance (VT), defined as function of WWR, where Effective Aperture >0.1, equal to or greater than the Minimum VT requirements of Table 6.6. The table also indicates recommended VT ranges for daylight applications in such spaces.

Table 6.6: Minimum VT requirements

WWR	Minimum VT
0–0.3	0.27
0.31–0.4	0.20
0.41–0.5	0.16
0.51–0.6	0.13
0.61–0.7	0.11

### 6.2.4 Skylights

Skylights shall comply with the maximum U-factor and maximum SHGC requirements of Table 6.7 Skylight area is limited to a maximum of 5% of the gross roof area for the prescriptive requirement.

Table 6.7: Skylight U-factor and SHGC Requirements

Climate	Maximum U-factor		Maximum SHGC	
	With curb	w/o curb	0-2% SRR	2.1–5% SRR
Composite	11.24	7.717	0.40	0.25
Hot and Dry	11.24	7.717	0.40	0.25
Warm and Humid	11.24	7.717	0.40	0.25
Moderate	11.24	7.717	0.61	0.4
Cold	11.24	7.717	0.61	0.4

SRR = Skylight roof ratio which is the ratio of the total skylight area of the roof, measured to the outside of the frame, to the gross exterior roof.

### 6.3 Building envelope trade-off option

The building envelope complies with the code if the building envelope performance factor (EPF) of the proposed design is less than the standard design, where the standard design exactly complies with the criteria in § 4.3. The envelope trade-off equation is as below:

#### Appendix E – Building Envelope Trade off Method

##### Equation

The envelope performance factor shall be calculated using the following equations.

where ,

$$\begin{aligned}
 EPF_{Total} &= EPF_{Roof} + EPF_{Wall} + EPF_{Fenest} \\
 EPF_{Roof} &= c_{Roof} \sum_{s=1}^n U_s A_s \\
 EPF_{Wall} &= c_{Wall,Mass} \sum_{s=1}^n U_s A_s + c_{Wall,Other} \sum_{s=1}^n U_s A_s \\
 EPF_{Fenest} &= c_{1Fenest,North} \sum_{w=1}^n SHGC_w M_w A_w + c_{2Fenest,North} \sum_{w=1}^n U_w A_w + \\
 & c_{1Fenest,NonNorth} \sum_{w=1}^n SHGC_w M_w A_w + c_{2Fenest,NonNorth} \sum_{w=1}^n U_w A_w + \\
 & c_{1Fenest,Skylight} \sum_{s=1}^n SHGC_s A_s + c_{2Fenest,Skylight} \sum_{s=1}^n U_s A_s
 \end{aligned}$$

$EPF_{Roof}$  – Envelope performance factor for roofs. Other subscripts include walls and fenestration.  
 $A_s, A_w$  – The area of a specific envelope component referenced by the subscript "s" or for windows the subscript "w".  
 $SHGC_w$  – The solar heat gain coefficient for windows (w).  
 $SHGC_s$  refers to skylights.  
 $M_w$  – A multiplier for the window SHGC that depends on the projection factor of an overhang or sidefin.  
 $U_s$  – The U-factor for the envelope component referenced by the subscript "s".  
 $c_{Roof}$  – A coefficient for the "Roof" class of construction. Values of "c" are taken from Table 6.7 through Table 6.11 for each class of construction.

Table 6.8: Envelope performance factor coefficients – Composite climate

	Daytime occupancy		24-Hour Occupancy	
	U-factor	SHGC	U-factor	SHGC
Mass walls	6.01	--	13.85	
Curtain walls, Other	15.72	--	20.48	
Roofs	11.93		24.67	
North windows	-1.75	40.65	-4.56	58.15
Non-North windows	-1.25	54.51	0.68	86.57
Skylights	-96.35	311.71	-294.66	918.77

Table 6.9: Envelope performance factor coefficients – Hot dry climate

	Daytime Occupancy	24-Hour Occupancy

	U-factor	SHGC	U-factor	SHGC
Mass Walls	5.48	-	15.01	-
Curtain Walls, Other	6.38	-	22.06	-
Roofs	11.14	-	25.98	-
North Windows	-2.40	36.57	-1.49	56.09
Non-North Windows	-1.86	46.79	1.187	81.79
Skylights	-96.27	309.33	- 295.81	923.01

Table 6.10: Envelope Performance Factor Coefficients – Hot Humid Climate

	Daytime Occupancy		24-Hour Occupancy	
	U-factor	SHG C	U-factor	SHGC
Mass Walls	6.42	-	9.60	-
Curtain Walls, Other	14.77	-	19.71	-
Roofs	9.86	-	14.11	-
North Windows	-1.58	34.9 5	-7.29	64.19
Non-North Windows	-1.00	43.0 9	-6.48	76.83
Skylights	-96.11	305. 45	-295.45	893.55

Table 6.11: Envelope Performance Factor Coefficients – Moderate Climate

	Daytime Occupancy		24-Hour Occupancy	
	U-factor	SHGC	U-factor	SHGC
Mass Walls	2.017	-	3.11	-
Curtain Walls, Other	2.72	-	4.11	-
Roofs	5.46	-	5.86	-
North Windows	-3.10	29.66	-11.95	62.14
Non-North Windows	-2.98	34.86	-11.62	68.45
Skylights	-96.21	298.82	- 294.12	876.70

Table 6.12: Envelope Performance Factor Coefficients – Cold Climate

	Daytime		24-Hour	
	Occupancy		Occupancy	
	U-factor	SHGC	U-factor	SHGC
Mass Walls	5.19	-	5.19	-
Curtain Walls, Other	6.76	-	6.76	-
Roofs	5.69	-	5.67	-
North Windows	1.55	9.13	1.55	9.13
Non-North Windows	-1.13	16.32	-1.13	16.32
Skylights	-93.44	283.18	-93.44	283.18

#### Overhang and side fin coefficients

The “M” multiplication factor can also be calculated using equation below. If the equation is used, a separate calculation shall be made for each orientation and unique shading condition.

Equation:  $M = a \cdot PF^2 + b \cdot PF + 1$

#### Budget building definition

1. The following rules shall be used to define the budget building.
2. The budget building shall have the same building floor area, gross wall area and gross roof area as the proposed design. If the building has both 24-hour and daytime occupancies, the distribution between these shall be the same as the proposed design.  
The U-factor of each envelope component shall be equal to the criteria from Table 6.2 for each class of construction.
3. The vertical fenestration area shall be equal to the proposed design or 40% of the gross exterior wall area, which ever is less. The skylight area shall be equal to the proposed design or 5% of the gross exterior roof area, which ever is less.
4. The SHGC of each window or skylight component shall be equal to the criteria from 6.2

## 6.4 Lighting

India generates about 101 630 MW (megawatts) of electricity (as of 2001). Of this, approximately 17% is consumed in the commercial/public sector and about 10% in the domestic sector. Lighting constitutes a key component of energy consumption in buildings. Typically in a fully air conditioned office building in India, lighting constitutes about 20% of total energy consumption. According to TERI’s estimates, in India , about 15% of the total electricity generated is used for lighting in various sectors. However, with advent of new technological solutions and knowledge on harnessing natural sources of

energy, energy consumption in lighting can be significantly reduced.

Good lighting aims at illuminating the task effectively and the general surroundings appropriately. Good lighting design enhances architecture but energy-efficient lighting design enhances both the design and the performance of building. Energy-efficient lighting design focuses on methods and materials that improve both quality and efficiency of lighting. A good lighting design should be able to provide desired quantity and quality of light at minimum energy consumption

An energy efficient approach to design for energy efficient lighting aims to cover the following aspects.

- Illuminance level for specified task
- Use of efficient lighting equipment e.g. lamps, luminaries and control gears
- Use of appropriate controls.
- Explore possibilities of daylight integration
- Ensure effective maintenance

Additionally the following parameters are also critical to a good lighting design:

- Room surface brightness
- Glare reduction
- Uniform light distribution
- Good lamp coloration

#### 6.4.1 Design for specified illumination level as recommended by the National building code 2005

The basic intent in an efficient lighting design to achieve the desired illumination level and light quality at minimum energy use. For the purpose of achieving the desired objectives, the following procedure should be followed to ensure efficient lighting

Illumination level for specified task should be maintained at all times as recommended by National building code 2005.

The National Building Code recommends a range of illumination levels for a activity as circumstances may be significantly different for different interiors used for the same application or for different conditions for the same kind of activity. Each range consists of three successive steps of recommended scale of illuminance. For working interiors, the middle value of each range represents the recommended service illuminance that should be used unless one or more of the factors mentioned below apply.

The higher value of the range should be used when:

- Unusually low reflectance or contrasts are present in the task;
- Errors are costly to rectify
- Visual work is critical
- Accuracy or high productivity is of great importance; and



- The visual capacity of the worker makes it necessary.

The lower value of the range may be used when:

- Reflectance or contrast are unusually high;
- Speed and accuracy is not important; and
- The task is executed only occasionally.

Where a visual task is required to be carried out through an interior, general illumination level meeting the recommended value on the working plane is necessary; where the precise height and location of the task are not known or cannot be easily specified, the recommended value is that on horizontal 850 mm above floor level.

*Note: For an industrial task, working plane for the purpose of general illumination levels is that on a work place which is generally 750 mm above the floor level. For certain purposes, such as viewing the objects of arts, the illumination levels recommended are for the vertical plane at which the art pieces are placed.*

Where the task is localised, the recommended value is that for the task only; it need not, and sometimes should not, be the general level of illumination used throughout the interior. Some processes, such as industrial inspection process, call for lighting of specialized design, in which case the level of illumination is only one of the several factors to be taken into account.

Table 6.13: Recommended Values of illuminance for some common activities as recommended by National Building Code 2005

Sl. No.	Type of interior or activity	Range of service illuminance in Lux	Quality class of direct glare limitation	Remarks
1	Commerce			
1.1	Offices			
1.1.1	General Offices	300-500-700	1	
1.1.2	Deep plan general offices	500-750-1000	1	
1.1.3	Computer work stations	300-500-750	1	
1.1.4	Conference rooms, executive offices	300-500-750	1	
1.1.5	Computer and data preparation rooms	300-500-750	1	

Sl. No.	Type of interior or activity	Range of service illuminance in Lux	Quality class of direct glare limitation	Remarks
1.1.6	Filing rooms	200-300-500	1	
1.2	Drawing offices			
1.2.1	General	300-500-750	1	
1.2.2.	Drawing boards	500-750-1000	1	
1.2.3	Computer aided design and drafting	-	-	Special lighting is required
1.2.4	Print rooms	200-300-500	1	
1.3	Banks and building societies			
1.3.1	Counter office area	300-500-750	1	
1.3.2	Public area	200-300-500	1	
2	Retailing			
2.1	Small shops with counters	300-500-750	1	The service illuminance should be provided on the horizontal plane of the counter. Where wall displays are used, a similar illuminance on the wall is desirable.
2.2	Small service shops with Island Displays	300-500-750	1	
2.3	Super markets, Hyper Markets			
2.3.1	General	300-500-750	2	
2.3.2	Checkout	300-500-750	2	
2.3.3	Showroom for large objects, for example, cars, furnitures.	300-500-750	1	
2.3.4	Shopping precincts and arcades	100-150-200	2	
3	Places of Public Assembly			
3.1	Public rooms, village halls, worship halls	200-300-500	1	
3.2	Concert Halls, Cinemas and Theaters			
3.2.1	Foyer	150-200-300	-	

Sl. No.	Type of interior or activity	Range of service illuminance in Lux	Quality class of direct glare limitation	Remarks
3.2.2	Booking Office	200-300-500	-	Local or localized lighting may be appropriate
3.2.3	Auditorium	50-100-150	-	Dimming facilities will be necessary. Special lighting of the aisles is desirable.
3.2.4	Dressing rooms	200-300-500	-	Special mirror lighting for make up may be required.
3.2.5	Projection room	100-150-200	-	
3.3	Churches			
3.3.1	Body of church	100-150-200	2	
3.3.2	Pulpit, lectern	200-300-500	2	Use local lighting
3.3.3	Choir stalls	200-300-500	2	Local lighting may be appropriate.
3.3.4	Alter, communion table, chancel	100-150-200	2	Additional lighting to provide emphasis is desirable
3.3.5	Vestries	100-150-200	2	
3.3.6	Organ	200-300-500	-	
3.4	Hospitals			
3.4.1	Anaesthetic rooms			
3.4.1.1	General	200-300-500	-	
3.4.1.2	Local	750-1000-1500	-	
3.4.2	Consulting area			
3.4.2.1	General	200-300-500	-	
3.4.2.2	Examination	750-1000-1500	-	
3.4.3	Corridors			
3.4.3.1	General	100-150-200	-	
3.4.4	Ward corridors			
3.4.4.1	Day, screened from bays	150-200-300	-	
3.4.4.2	Day, open to natural light	150-200-300 (Total)	-	
3.4.4.3	Morning/Evening	100-150-200	-	
3.4.4.4	Night	5-10	-	
3.4.5	Cubicles			
3.4.5.1	General	200-300-500	-	
3.4.5.2	Treatment	750-1000-1500	-	
3.4.6	Examination			

Sl. No.	Type of interior or activity	Range of service illuminance in Lux	Quality class of direct glare limitation	Remarks
3.4.6.1	General	200-300-500		
3.4.6.2	Local inspection	750-1000-1500		
3.4.7	Intensive therapy			
3.4.7.1	Bed head	30-50		
3.4.7.2	Circulation between bed ends	50-100-150		
3.4.7.3	Observation	200-300-500	-	
3.4.7.4	Local Observation	750-100-1500		
3.4.7.5	Staff base (day)	200-300-500		
3.4.7.6	Staff base (night)	30		
3.4.8	Laboratories			
3.4.8.1	General	200-300-500	-	
3.4.8.2	Examination	300-500-750	-	
3.4.9	Nurse's station			
3.4.9.1	Morning/day/evening	200-300-500	-	
3.4.9.2	Night desks	30	-	
3.4.9.3	Night, medical trolleys	50-100-150	-	
3.4.10	Operating Theatres			
3.4.10.1	General	300-500-750		
3.4.10.2	Local	10000 to 50000	-	Special operating lights are used
3.4.11	Pathology departments			
3.4.11.1	General	200-300-500		
3.4.11.2	Examination	300-500-750		
3.4.11.3	Pharmacies	200-300-500		
3.4.11.4	Reception/enquiry	200-300-500		
3.4.11.5	Recovery rooms	200-300-500		
3.4.12	Ward-circulation			
3.4.12.1	Day	50-100-150		
3.4.12.2	Morning / Evening	50-100-150		
3.4.12.3	Night	3-5		
3.4.13	Ward-bed head			

Sl. No.	Type of interior or activity	Range of service illuminance in Lux	Quality class of direct glare limitation	Remarks
3.4.13.1	Morning/ Evening	30-50		
3.4.13.2	Reading	100-150-200		
3.4.14	Night			
3.4.14.1	Adult	0.1-1		
3.4.14.2	Pediatric	1		
3.4.14.3	Psychiatric	1-5		
3.4.14.4	Watch	5		
3.4.15	X-Ray areas			
3.4.15.1	General	150-200-300		
3.4.15.2	Diagnostic	150-200-300		
3.4.15.3	Operative	200-300-500		
3.4.15.4	Process dark room	50		
3.4.16	Surgeries			
3.4.16.1	General	150-200-300		
3.4.16.2	Waiting rooms	100-150-200		
3.4.17	Dental Surgeries			
3.4.17.1	Chair	Special lighting		
3.4.17.2	Laboratories	300-500-750	-	
3.4.18	Consulting Rooms			
3.4.18.1	General	200-300-500		
3.4.18.2	Desk	300-500-750	-	
3.4.18.3	Examination Couch	300-500-750	-	
3.4.18.4	Ophthalmic Walls and near-vision charts	300-500-750	-	
3.5	Hotels			
3.5.1	Entrance Halls	50-100-150		
3.5.2	Reception, cashier's and porter's desk	200-300-500	-	Localised lighting may be appropriate
3.5.3	Bars, Coffee base, dining rooms, grill rooms, restaurants, lounges	50-200		The lighting should be designed to create an appropriate atmosphere.
3.5.4	Cloak Rooms, baggage rooms	50-100-150	3	

Sl. No.	Type of interior or activity	Range of service illuminance in Lux	Quality class of direct glare limitation	Remarks
3.5.5	Bed Rooms	30-50-100	-	Supplementary local lighting at the bed head, writing table should be provided.
3.5.6	Bathroom	50-100-150	-	Supplementary local lighting near the mirror is desirable
3.5.7	Food preparation and stores, cellars, lifts and corridors	-	-	See 'General Building Areas'
3.6	Libraries			
3.6.1	Lending Library			
3.6.1.1	General	200-300-500	1	
3.6.1.2	Counters	300-500-750	1	Localised lighting may be appropriate
3.6.1.3	Bookshelves	100-150-200	2	The service illuminance should be provided on the vertical face at the bottom of the bookstack.
3.6.1.4	Reading Rooms	200-300-500	1	
3.6.1.5	Reading Tables	200-300-500	1	Localised lighting may be appropriate
3.6.2	Catalogues			
3.6.2.1	Card	100-150-200	2	
3.6.2.2	Microfiche/ Visual display units	100-150-200	2	
3.6.3	Reference Libraries			
3.6.3.1	General	200-300-500	1	
3.6.3.2	Counters	300-500-750	1	Localised lighting may be appropriate
3.6.3.3	Bookshelves	100-150-200	2	The service illuminance should be provided on a vertical surface at the foot of the bookshelves.
3.6.3.4	Study tables, carrels	300-500-750	1	
3.6.3.5	Map room	200-300-500	1	
3.6.4	Display and exhibition areas			

Sl. No.	Type of interior or activity	Range of service illuminance in Lux	Quality class of direct glare limitation	Remarks
3.6.4.1	Exhibits insensitive to lights	200-300-500	-	
3.6.4.2	Exhibit sensitive to light, for example, pictures, prints, rare books in archives	50 to 150	-	
3.6.5	Library Workrooms			
3.6.5.1	Book repair and book binding	300-500-750	2	
3.6.5.2	Catalogue and sorting	300-500-750	2	
3.6.5.3	Remote book stores	100-150-200	3	
3.7	Museums and Art Galleries			
3.7.1	Exhibits insensitive to light	200-300-500	-	
3.7.2	Light sensitive exhibits for example, oil and temper paints, undyed leather, bone, ivory, wood etc.	150	-	This is the maximum illuminance to be provided on the principal plane of the exhibit.
3.7.3	Extremely light sensitive exhibits, for example, oil and temper paints, undyed leather, bone, ivory, wood, etc.	50	-	This is the maximum illuminance to be provided on the principal plane of the object.
3.8	Sports Facilities			

Sl. No.	Type of interior or activity	Range of service illuminance in Lux	Quality class of direct glare limitation	Remarks
	Multi purpose sports halls	300-750	-	The lighting system should be sufficiently flexible to provide lighting suitable for the variety of sports and activities that take place in sports halls. Higher illuminance of 1000-2000 lux would be required for television coverage.
4	Education			
4.1	Assembly Halls			
4.1.1.	General	200-300-500	3	
4.1.2.	Platform and stage	-	-	Special lighting to provide emphasise and to facilitate the use of the platform/stage is desirable.
4.2	Teaching spaces			
	General	200-300-500	1	
4.3	Lecture Theatres			
4.3.1	General	200-300-500	1	
4.3.2	Demonstration benches	300-500-750	1	Localised lighting may be appropriate
4.4	Seminar rooms	300-500-750	1	Localized lighting may be appropriate
4.5	Art rooms	300-500-750	1	
4.6	Needlework Rooms	300-500-750	1	
4.7	Laboratories	300-500-750	1	
4.8	Libraries	200-300-500	1	
4.9	Music Rooms	200-300-500	1	
4.10	Sports Halls	200-300-500	1	
4.11	Workshops	200-300-500	1	
5	General Building Areas			
5.1	Entrance			
5.1.1	Entrance halls, lobbies, waiting rooms	150-200-300	2	
5.1.2	Enquiry desks	300-500-750	2	Localised lighting may be appropriate.
5.1.3	Gatehouses	150-200-300	2	



Sl. No.	Type of interior or activity	Range of service illuminance in Lux	Quality class of direct glare limitation	Remarks
5.2	Circulation areas			
5.2.1	Lifts	50-100-150	-	
5.2.2	Corridors, passageways, stairs	50-100-150	2	
5.2.3	Escalators, travelators	100-150-200		
5.3	Medical and First aid centers			
5.3.1	Consulting rooms, treatment rooms	300-500-750	2	
5.3.2	Rest rooms	100-150-200	1	
5.3.3	Medical stores	100-150-200	1	
5.4	Staff Rooms			
5.4.1	Changing, locker and cleaners rooms, cloakrooms, lavatories	50-100-150	-	
5.4.2	Rest rooms	100-150-200	1	
5.5	Staff Restaurants			
5.5.1	Canteens, cafeterias, dining rooms, mess rooms	150-200-300	2	
5.5.2	Servery, vegetable preparation, washing-up area	200-300-500	2	
5.5.3	Food Preparation and cooking	300-500-750	2	
5.5.4	Food stores, cellars	100-150-200	2	
5.6	Communication s			
5.6.1.	Switchboard rooms	200-300-500	2	

Sl. No.	Type of interior or activity	Range of service illuminance in Lux	Quality class of direct glare limitation	Remarks
5.6.2	Telephone apparatus rooms	100-150-200	2	
5.6.3	Telex room, post room	300-500-750	2	
5.6.4	Reprographic room	200-300-500	2	
5.7	Building Services			
5.7.1	Boiler houses			
5.7.1.1	General	50-100-150	3	
5.7.1.2	Boiler Front	100-150-200	3	
5.7.1.3	Boiler Control Room	200-300-500	2	Localized lighting of the control display and the control desk may be appropriate
5.7.1.4.	Control rooms	200-300-500	2	Localized lighting of the control display and the control desk may be appropriate
5.7.1.5	Mechanical Plant room	100-150-200	2	
5.7.1.6	Electrical power supply and distribution rooms	100-150-200	2	
5.7.1.7	Store rooms	50-100-150	3	
5.8	Car Parks			
5.8.1	Covered Car Parks			
5.8.1.1	Floors	5-20	-	
5.8.1.2	Ramps and Corners	30	-	
5.8.1.3	Entrances and exits	50-100-150	-	
5.8.1.4	Control booths	150-200-300	-	
5.8.1.5	Outdoor Car Parks	5-20	-	

*The lighting design should conform to following recommendations of the Draft Energy Conservation Building Code 2006 drafted by the Bureau of Energy Efficiency, GoI.*

Follow the mandatory and prescriptive requirements of the energy conservation building code as detailed below:

### *General*

Lighting systems and equipment shall comply with the provisions of Energy conservation building Code as outlined below:

The lighting requirements in this section shall apply to:

- (a) Interior spaces of buildings,
- (b) Exterior building features, including facades, illuminated roofs, architectural features, entrances, exits, loading docks, and illuminated canopies, and,
- (c) Exterior building grounds lighting that is provided through the building's electrical service.

Exceptions to above:

- (a) Emergency lighting that is automatically off during normal building operation and is powered by battery, generator, or other alternate power source; and,
- (b) Lighting in dwelling units except for dwelling units where the developer is providing lighting fixtures inside the units (however, common area lighting of residential complexes fall under purview of the code)

### 6.4.2 Interior lighting power

The installed interior lighting power for a building shall not exceed the interior lighting power allowance determined in accordance with either Table 6.14 or 6.15.

#### **Exceptions:**

The following lighting equipment and applications shall not be considered when determining the interior lighting power allowance, nor shall the wattage for such lighting be included in the installed interior lighting power. However, any such lighting shall not be exempt unless it is an addition to general lighting and is controlled by an independent control device.

- Display or accent lighting that is an essential element for the function performed in galleries, museums, and monuments,
- Lighting that is integral to equipment or instrumentation and is installed by its manufacturer,
- Lighting specifically designed for medical or dental procedures and lighting integral to medical equipment,
- Lighting integral to food warming and food preparation equipment,
- Lighting for plant growth or maintenance,
- Lighting in spaces specifically designed for use by the visually impaired,
- Lighting in retail display windows, provided the display area is enclosed by ceiling height partitions,
- Lighting in interior spaces that have been specifically designated as a registered interior historic landmark,
- Lighting that is an integral part of advertising or directional signage,
- Exit signs,
- Lighting that is for sale or lighting educational demonstration systems,
- Lighting for theatrical purposes, including performance, stage, and film or video production
- Athletic playing areas with permanent facilities for television broadcasting.

### *Building area method*

Determination of interior lighting power allowance (watts) by the building area method shall be in accordance with the following:

- a. Determine the allowed lighting power density from Table 6.15 for each appropriate building area type.

- b. Calculate the gross lighted floor area for each building area type.
- c. The interior lighting power allowance is the sum of the products of the gross lighted floor area of each building area times the allowed lighting power density for that building area types.

Table 6.14 Interior lighting power – building area method

Building Area Type	LPD (W/m <sup>2</sup> )	Building Area Type	LPD (W/m <sup>2</sup> )
Automotive Facility	9.7	Multifamily	7.5
Convention Center	12.9	Museum	11.8
Court House	12.9	Office	10.8
Dining: Bar		Parking Garage	
Lounge/Leisure	14.0		3.2
Dining:		Penitentiary	
Cafeteria/Fast Food	15.1		10.8
Dining: Family		Performing Arts	
	17.2	Theater	17.2
Dormitory		Police/Fire	
	10.8	Station	10.8
Exercise Center	10.8	Post Office	11.8
Gymnasium	11.8	Religious Building	14.0
Healthcare-Clinic	10.8	Retail	16.1
Hospital/Health		School/University	
Care	12.9		12.9
Hotel	10.8	Sports Arena	11.8
Library	14.0	Town Hall	11.8
Manufacturing		Transportation	
Facility	14.0		10.8
Motel	10.8	Warehouse	8.6
Motion Picture		Workshop	
Theater	12.9		15.1

In cases where both a general building area type and a specific building area type are listed, the specific building area type shall apply.

Or,

#### Space Function Method

Determination of interior lighting power allowance (watts) by the space function method shall be in accordance with the following:

- a. Determine the appropriate building type from Table 6.16 and the allowed lighting power density.
- b. For each space enclosed by partitions 80% or greater than ceiling height, determine the gross interior floor area by measuring to the center of the partition wall. Include the floor area of balconies or other projections. Retail spaces do not have to comply with the 80% partition height requirements.

- c. The interior lighting power allowance is the sum of the lighting power allowances for all spaces. The lighting power allowance for a space is the product of the gross lighted floor area of the space times the allowed lighting power density for that space.

Table 6.15 Interior lighting power – space function method

Space Function	LPD (W/m <sup>2</sup> )	Space Function	LPD (W/m <sup>2</sup> )
Office-enclosed	11.8	Library	
Office-open plan	11.8	Card File & Cataloging	11.8
Conference/Meeting/Multipurpose	14.0	Stacks	18.3
Classroom/Lecture/Training	15.1	Reading Area	12.9
Lobby	14.0	Hospital	
For Hotel	11.8	Emergency	29.1
For Performing Arts Theater	35.5	Recovery	8.6
For Motion Picture Theater	11.8	Nurse Station	10.8
Audience/Seating Area	9.7	Exam Treatment	16.1
For Gymnasium	4.3	Pharmacy	12.9
For Exercise Center	3.2	Patient Room	7.5
For Convention Center	7.5	Operating Room	23.7
For Religious Buildings	18.3	Nursery	6.5
For Sports Arena	4.3	Medical Supply	15.1
For Performing Arts Theater	28.0	Physical Therapy	9.7
For Motion Picture Theater	12.9	Radiology	4.3
For Transportation	5.4	Laundry – Washing	6.5
Atrium-first three floors	6.5	Automotive – Service Repair	7.5
Atrium-each additional floor	2.2	Manufacturing	
Lounge/Recreation	12.9	Low Bay (<8m ceiling)	12.9
For Hospital	8.6	High Bay (>8m ceiling)	18.3
Dining Area	9.7	Detailed	
For Hotel	14.0	Manufacturing	22.6
For Motel	12.9	Equipment Room	12.9
For Bar Lounge/Leisure Dining	15.1	Control Room	5.4
For Family Dining	22.6	Hotel/Motel Guest Rooms	11.8
Food Preparation	12.9	Dormitory – Living Quarters	11.8
Laboratory	15.1	Museum	
Restrooms	9.7	General Exhibition	10.8
Dressing/Locker/Fitting Room	6.5	Restoration	18.3
Corridor/Transition	5.4	Bank Office – Banking	
For Hospital	10.8	Activity Area	16.1
For Manufacturing Facility	5.4	Religions Buildings	
		Worship-pulpit, choir	25.8
		Fellowship Hall	9.7

Space Function	LPD (W/m <sup>2</sup> )	Space Function	LPD (W/m <sup>2</sup> )
Stairs-active	6.5	Retail	
Active Storage	8.6	Sales Area	18.3
For Hospital	9.7	Mall Concourse	18.3
Inactive Storage	3.2	Sports Arena	
For Museum	8.6	Ring Sports Area	29.1
Electrical/Mechanical	16.1	Court Sports Area	24.8
Workshop	20.5	Indoor Field Area	15.1
Sleeping Quarters	3.2	Warehouse	
Convention Center – Exhibit Space	14.0	Fine Material Storage	
			15.1
		Medium/Bulky	
		Material Storage	9.7
		Parking Garage –	
		Garage Area	2.2
		Transportation	
		Airport – Concourse	6.5
		Air/Train/Bus –	
		Baggage Area	10.8
		Terminal – Ticket	
		Counter	16.1

### *Installed interior lighting power*

The installed interior lighting power calculated for compliance with 6.3 shall include all power used by the luminaires, including lamps, ballasts, current regulators, and control.

Exception to 6.6.3: If two or more independently operating lighting systems in a space are controlled to prevent simultaneous user operation, the installed interior lighting power shall be based solely on the lighting system with the highest power devices except as specifically exempted in 7.1.

### Luminaire wattage

Luminaire wattage incorporated into the installed interior lighting power shall be determined in accordance with the following:

- a. The wattage of incandescent luminaires with medium base sockets and not containing permanently installed ballasts shall be the maximum labeled wattage of the luminaires.
- b. The wattage of luminaires containing permanently installed ballasts shall be the operating input wattage of the specified lamp/ballast combination based on values from manufacturers' catalogs or values from independent testing laboratory reports.
- c. The wattage of all other miscellaneous luminaire types not described in (a) or (b) shall be the specified wattage of the luminaires.

- d. The wattage of lighting track, plug-in busway, and flexible-lighting systems that allow the addition and/or relocation of luminaires without altering the wiring of the system shall be the larger of the specified wattage of the luminaires included in the system or 135 W/m (45 W/ft). Systems with integral overload protection, such as fuses or circuit breakers, shall be rated at 100% of the maximum rated load of the limiting device.

#### 6.4.3 Exterior lighting power

For building exterior lighting applications specified in Table 6.16, the connected lighting power shall not exceed the specified lighting power limits specified for each of these applications. Exterior lighting for all other applications (except those included in the Exceptions to Table 6.16) shall comply with the requirements of 6.7

Table 6.16 Exterior Building Lighting Power

Exterior Lighting Applications	Power Limits
Building entrance (with canopy)	13 W/m <sup>2</sup> (1.3 W/ft <sup>2</sup> ) of canopied area
Building entrance (without canopy)	90 W/lin m (30 W/lin f) of door width
Building exit	60 W/lin m (20 W/lin f) of door width
Building facades	2 W/m <sup>2</sup> (0.2 W/ft <sup>2</sup> ) of vertical facade area

Exceptions 6.4.3: Lighting used for the following exterior applications is exempt when equipped with an independent control device:

- (a) Specialized signal, directional, and marker lighting associated with transportation;
- (b) Lighting used to highlight features of public monuments and registered historic landmark structures or buildings;
- (c) Lighting that is integral to advertising signage; or
- (d) Lighting that is specifically designated as required by a health or life safety statute, ordinance, or regulation.

#### *Energy efficient lighting: some basic steps*

The light power densities as recommended by the ECBC are the maximum recommended standards. It is strongly recommended to design lighting schemes with LPD values lower than as specified by the ECBC, yet achieving the NBC specified lighting levels. The following section provides select information on lighting equipment which would be useful for designers.

Energy conservation in lighting can be achieved

- by use of efficient lamps, luminaries and control devices
- by reducing wastage
- by ensuring proper utilization of daylight and control glare from windows
- by maintaining lighter finishes of ceiling, walls and furnishings,

- by implementing periodic schedule for cleaning of luminaries and group replacement of lamps at suitable intervals.

Choice of light sources with higher luminous efficacy and luminaries with appropriate light distribution is the most effective means of energy saving in lighting. The major considerations in selection of the lamps and luminaires are the following.

- Illuminance level for the task
- CRI of the light source
- Arrangement of the lamp, including mounting height
- Lamp type (lumen output), size (watt), and likely lifespan (hours)
- Type of luminaire, including mirror optics

Luminous efficacy of some of the lamps used in lighting of buildings are given in Table 6.17 along with average life in burning hours, Colour Rendering Index and Colour Temperature (ref NBC2005).

Table no. 6.17 Luminous efficacy of lamps

Sl. No.	Light Source	Efficacy Lm/W	Average Life h	CRI	CCT
i)	Incandescent lamps GLS 25 W – 1000 W	8-18	1000	100	2800
ii)	Tungsten halogen incandescent lamps Mains – voltage types : 60 W – 2000 W low-voltage types with reflector have low wattages	10% higher than comparable GLS Lamps	2000	100	2800-3200
iii)	Fluorescent Lamps (FTL)				
	a) Standard Lamps				
	38 mm (T12) 20W-65W				
	26 mm (T8) 18W-58W				
	Cool daylight	61	5000	72	6500
	Warm White	67	5000	57	3500



Sl. No.	Light Source	Efficacy Lm/W	Average Life h	CRI	CCT
b)	Tri-Phosper lamps 38 mm (T12) 20 W – 65 W 26 mm (T8) 18 W- 58 W	880-104	12000- 18000	85-95	2700-6500
iv)	Compact Fluorescent Lamps (CFL) 5 W-25 W	40-80	8000	Similar to FTL	
v)	High Pressure Mercury vapour lamps 80 W- 400 w	36-60	5000	45	4000
vi)	Blended – Light Lamps	11-26	5000	61	3600
vii)	High Pressure sodium Vapour Lamps 50 W – 1000 W	69 – 130	10000 – 15000	23	2000
viii)	Metal halide lamps 35 w – 2000 W	69 –83	10000	68-92	3000-5000

#### Notes

1. The table includes lamps and wattages currently in use in buildings in India.
2. Luminous efficacy varies with the wattage of the lamp.
3. Average life values are from available Indian Standards. Where Indian Standards is not available, values given are only indicative.
4. CRI and CCT values are only indicative.
5. For exact values, it is advisable to contact manufacturers.

#### *Luminaire efficiency*

The efficiency of a luminaire is the percentage of lamp lumens produced that exit the fixture. Use of louvers improve visual comfort, reduce glare but reduces efficiency. It is thus important to determine the best compromise between efficiency and visual comfort probability while choosing luminaires. A lighting simulation is necessary to determine the type of luminaire and lamp combination for a specific application.

Efficient luminaire also plays an important role for energy conservation in lighting. The choice of a luminaire should be such that it is efficient not only initially but also throughout its life. Following luminaires are recommended by the NBC 2005 for different locations:

- For offices semi-direct of luminaires are recommended so that both the work plane illumination and surround luminance can be effectively enhanced.

- For corridors and staircases direct type of luminaries with wide spread of light distribution are recommended.
- In residential buildings, bare fluorescent tubes are recommended. Wherever the incandescent lamps are employed, they should be provided with white enameled conical reflectors at an inclination of about 45° from vertical.

### *Ballasts*

All discharge lamps, including fluorescents, require a ballast for proper operation. Typical ballast losses are taken as approximately 15% of the lamp wattage. It is important to include calculation of ballast losses when comparing consumption and savings for different kinds of lamps. New electronic or solid state ballasts, now available in market, save approximately 20–30% in energy consumption over standard ballasts.

### 6.4.4 Lighting controls

Reducing the connected load of the lighting system represents partly the potential for maximizing energy savings. Lighting controls play a major role in reducing energy consumption by avoiding wastages. There are numerous choices available today from simple light switches to fully automated systems. Automatic controls switch off or dim the lights based on the time, occupancy, illumination requirements, or a combination of all three.

Following are the recommendations of the ECBC on provision for lighting control in buildings

#### Automatic Lighting Shutoff

Interior lighting systems in buildings larger than 500 m<sup>2</sup> (5,000 ft<sup>2</sup>) shall be equipped with an automatic control device. Within these buildings, all office areas less than 30 m<sup>2</sup> (300 ft<sup>2</sup>) enclosed by walls or ceiling-height partitions, all meeting and conference rooms, all school classrooms, and all storage spaces shall be equipped with occupancy sensors. For other spaces, this automatic control device shall function on either

- a. A scheduled basis at specific programmed times. An independent program schedule shall be provided for areas of no more than 2,500 m<sup>2</sup> (25,000 ft<sup>2</sup>) and not more than one floor; or,
- b. Occupancy sensors that shall turn the lighting off within 30 minutes of an occupant leaving the space. Light fixtures controlled by occupancy sensors shall have a wallmounted, manual switch capable of turning off lights when the space is occupied. Exception to 6.4.4.: Lighting systems designed for 24-hour use.

### Space Control

Each space enclosed by ceiling-height partitions shall have at least one control device to independently control the general lighting within the space. Each control device shall be activated either manually by an occupant or automatically by sensing an occupant. Each control device shall

- a. Control a maximum of 250 m<sup>2</sup> (2,500 ft<sup>2</sup>) for a space less than or equal to 1,000 m<sup>2</sup> (10,000 ft<sup>2</sup>), and a maximum of 1,000 m<sup>2</sup> (10,000 ft<sup>2</sup>) for a space greater than 1,000 m<sup>2</sup> (10,000 ft<sup>2</sup>).
- b. Be capable of overriding the shutoff control required no more than 2 hours, and
- c. Be readily accessible and located so the occupant can see the control.

Exception to 6.4.4 The required control device may be remotely installed if required for reasons of safety or security. A remotely located device shall have a pilot light indicator as part of or next to the control device and shall be clearly labeled to identify the controlled lighting.

### Control in Daylighted Areas

Luminaires in daylighted areas greater than 25 m<sup>2</sup> (250 ft<sup>2</sup>) shall be equipped with either a manual or automatic control device that:

- a. Is capable of reducing the light output of the luminaires in the daylit areas by at least 50%, and
- b. Controls only the luminaires located entirely within the daylit area.

### Exterior Lighting Control

Lighting for all exterior applications not exempted in 6.4 shall be controlled by a photosensor or astronomical time switch that is capable of automatically turning off the exterior lighting when daylight is available or the lighting is not required.

### Additional Control

The following lighting applications shall be equipped with a control device to control such lighting independently of general lighting:

- a. Display/Accent Lighting. Display or accent lighting greater than 300 m<sup>2</sup> (3,000 ft<sup>2</sup>) area shall have a separate control device.
- b. Case Lighting. Lighting in cases used for display purposes greater than 300 m<sup>2</sup> (3,000 ft<sup>2</sup>) area shall be equipped with a separate control device.
- c. Hotel and Motel Guest Room Lighting. Hotel and motel guest rooms and guest suites shall have a master control device at the main room entry that controls all permanently installed luminaires and switched receptacles.

- d. Task Lighting. Supplemental task lighting including permanently installed under shelf or under cabinet lighting shall have a control device integral to the luminaires or be controlled by a wall-mounted control device .
- e. Nonvisual Lighting. Lighting for nonvisual applications, such as plant growth and food-warming, shall be equipped with a separate control device.
- f. Demonstration Lighting. Lighting equipment that is for sale or for demonstrations in lighting education shall be equipped with a separate control device accessible only to authorized personnel.

#### Exit Signs

Internally - illuminated exit signs shall not exceed 5 W per face.

#### Exterior Building Grounds Lighting

Lighting for exterior building grounds luminaires which operate at greater than 100 W shall contain lamps having a minimum efficacy of 60 lm/W unless the luminaire is controlled by a motion sensor or exempt under 7.1

#### Common types of controls

##### *Timers*

These represent the most basic type of automation, and are very popular for outdoor applications. Timers can be simple (responding to one setting all year round) or sophisticated enough to contain several settings that go into effect over time.

##### *Occupancy sensors*

These devices – also known as ‘motion detectors’ – turn lights off and on in response to human presence. Once sensitivity and coverage area is established, sensors are selected from two predominant technology types.

1. Passive infrared sensors – These detect the motion or heat between vertical and horizontal detection zones. This technology requires a direct line of sight and is more sensitive to lateral motion, but it requires layer motion as distance from the sensor increases. The coverage pattern and field of view can also be precisely controlled. It typically finds its best application in smaller spaces with a direct line of sight, such as restrooms.
2. Ultrasonic sensors – These detect movement by sensing disturbances in high-frequency ultrasonic patterns. Because this technology emits ultrasonic waves that are reflected around the room surfaces, it does not require a direct line of sight. It is more sensitive to motion towards and away from the sensor and its sensitivity

decreases relative to its distances from the sensor. It also does not have a definable coverage pattern or field of view. These characteristics make it suitable for use in layer-enclosed areas that may have cabinets, shelving, partitions, or other obstructions. If necessary, these technologies can also be combined into one product to improve detection and reduce the likelihood of triggering a false on or off mode.

#### *Photocells*

These measure the amount of natural light available and suitable for both indoor and outdoor applications. When available light falls below a specified level, a control unit switches the lights on (or adjusts a driver to provide more light). Photocells can be programmed so that lights do not flip on and off on partially cloudy days.

#### *Energy management systems*

Sometimes known as building automation systems, these computer-driven systems also control lighting. An EMS (energy management system) is most effectively employed in the initial construction of a building, not as a retrofit application. By using a variety of control units tied to a centralized system, the building monitors its lighting system itself. However, settings can usually be overridden manually.

## 6.5 Daylight integration in buildings

Architectural form, from ancient history to modern times has always responded to daylight, the primary source of natural light from the sun. Daylight that enters a window can come from several sources: direct sunlight, clear (blue) sky, clouds, and reflections from the ground and nearby buildings.

It becomes important to distinguish between sunlight, intense direct beams of light from the sun, and daylight, which is the more gentle, useful and diffuse light. Daylighting has a major effect on the appearance of space and also has energy efficiency implications. It becomes important particularly in day-use buildings.

Thus window design is very critical to daylight integration in a buildings. A proper planning and window design along with daylight integration of artificial lights with help of daylinked controls can save 80-100% of lighting energy use during daytime. The following section gives window design guidelines to enable daylighting of interior spaces.

#### *Window design guidelines*

Windows are very important component of building envelope, which in addition to providing connection to exterior, bring in heat and light. The incoming solar radiation through windows provides natural lighting and heat gain to a space, thus impacting energy usage of the space. The main purpose of a

building and its window is to provide thermal and visual comfort to the occupants and if this comfort can be achieved while lower energy use, so much the better. Windows contribute significantly to energy use for space conditioning or natural lighting.

Glazing, framing and shading devices (internal and external) are primary components of a window having significant impact on energy use as well as on cost in buildings. Glazing usually forms the largest component that affects energy usage and cost. It is advisable to cut off solar gains before it reaches window (in cooling dominated climates) to maximize energy savings. On the other hand in heating dominated climates solar gain is welcome, but associated glare, overheating and UV degradation has to be dealt with at design stage.

*Recommendation for a “good” window design can be summarized as follows:*

Minimize east and west exposure in cooling dominated climates –it is difficult to provide protection on east and west façade. South orientation is most preferred for heating dominated climate. For cooling dominated climates, south should be adequately protected from direct solar gain by shading devices. North facing windows should be maximized for cooling dominated climate. Heat gain from north windows is minimum, and north windows offer significant daylight integration opportunities. In heating dominated climates, it is important to reduce heat losses through north windows by providing air tight windows and use of glazing with low U-factor.

It is advisable to keep natural shading and not to cut down shading trees prior to construction. Experience shows that the best exterior shade for east or west facing windows is a tall tree full with leaves. Deciduous trees are an effective shading device for south facing windows in climatic zones with substantial winter/summer temperature difference (composite climate). It is far better, for heat prevention to block sunlight before it reaches window, thereby dissipating the absorbed heat outside where it can be carried away by air currents.

If exterior shades are unwanted, use of light coloured interior blinds could be considered. However, opening and closing of blinds as per changing outdoor condition needs to be followed to take advantage of daylighting when desirable. The next step would be select glazing system for the window based on its functional, aesthetic and energy aspects.

*Glazing selection guidelines*

Glazing properties and their significance:

Glazing should be selected after careful evaluation of its properties, costs, applicability, energy saving potential and architectural requirements. The critical parameters which should be reviewed while selecting glazing are as follows:

Selection process

*Choose between dual-pane and single-pane glazing.*

Choice of single vs. double glazing is governed by first costs, and the energy saving potential. Although higher in first cost, dual-pane insulating glazing typically improves comfort in perimeter zones, reduces mechanical cooling loads and improves acoustic performance. Double glazed windows with solar control coatings have better solar control properties and also allow flexibility for daylight integration. Double glazing with spectrally selective coating further improves its insulating properties. Non air conditioned buildings in which windows are typically left open need not use double glazing. Buildings with both cooling and heating requirement need to weigh out the impact of double glazing on its heating and cooling loads. Use of double glazing would have positive impact on the cooling loads in summer months but may simultaneously increase the heating load in the same building during winter months.

*Choose a spectrally selective glazing.*

Choice of visible light transmittance in glass would depend on visual tasks, window size and glare sensitivity; the larger the windows or the more critical the glare control, the lower the desirable visible transmittance. Select glass with desirable visible transmittance and the lowest possible solar heat gain coefficient in a cooling dominated climate. For a heating dominated climate glass with high SHGC may be chosen. Spectrally selective glazing is typically a high cost option and its application should be governed by careful cost benefit analysis.

*Balance the conflict between glare and useful light.*

If glare is an anticipated problem try to use architectural interventions (deep reveals, shading systems etc) to cut down on glare. then select a glazing visible transmittance that is a compromise between glare and light. A visible transmittance of as low as 25% may still provide adequate daylight.

Glare problem if un anticipated at design stage could lead to incorrect design decisions e.g. Daylight linking of artificial lights may be planned in a day use building as a major component of energy savings. Accordingly, the designer would be selecting spectrally selective glazing with low shading coefficient and high visible light transmission. However in reality it may so happen that due to glare from the windows, one has to keep the internal blinds closed for most part of the day. This would nullify the daylight based savings and in turn increase energy consumption (due to artificial lighting being kept on during daytime and also due additional cooling load from the heat generated by these lights). Hence glare control strategies should be applied prior to final glazing selection.

Dark glass need not necessarily provide good solar control.

Many dark glazings block more light than heat, and therefore only minimally reduce cooling load. Dark glass not only reduces daylight, it also increases occupant discomfort on a sunny day, particularly in single glazed form. The glass absorbs solar energy and heats up, turning it into a virtual furnace for anyone sitting near it. Today, solar control is available in much clearer glazings.

Don't count on glazing alone to reduce heat gain and discomfort. If direct solar beams come into the building, they still create a mechanical cooling load and discomfort for occupants in their path. Exterior shading combined with a good glazing selection is the best window strategy. Interior shading options can also help control solar heat gain.

## 6.6 Solar Photovoltaic Systems (SPV)

Solar Photovoltaic systems enables direct conversion of sunlight into electricity and is viable option for lighting purpose in remote non grid areas. The common SPV lighting systems are: Solar lantern, Fixed type solar home lighting system, and Street lighting system.

## 6.7 Heating, ventilation and air conditioning

### 6.7.1 Heat load estimation

#### 6.7.1.1 Inside design conditions

The inside design conditions of a conditioned space should conform to as indicated in Table 6.18.

Table 6.18: Inside design conditions for some applications

Sl No.	Category	Inside Design Conditions	
		Summer (3)	Winter (4)
(1)	(2)		
i)	Restaurants	DB 23 to 26°C RH 55 to 60%	DB 21 to 23°C RH not less than 40%
ii)	Office buildings	DB 23 to 26°C RH 50 to 60%	DB 21 to 23°C RH not less than 40%
iii)	Radio and television studios	DB 23 to 26°C RH 45 to 55%	DB 21 to 23°C RH 40 to 50%
iv)	Departmental stores	DB 23 to 26°C RH 50 to 60%	DB 21 to 23°C RH not less than 40%
v)	Hotel guest rooms	DB 23 to 26°C RH 50 to 60%	DB 23 to 24°C RH not less than 40%
vi)	Class rooms	DB 23 to 26°C RH 50 to 60%	DB 23 to 24°C RH not less than 40%
vii)	Auditoriums	DB 23 to 26°C RH 50 to 60%	DB 23 to 24°C RH not less than 40%
viii)	Recovery rooms		DB 24 to 26°C RH 45 to 55%
ix)	Patient rooms		DB 24 to 26°C RH 45 to 55%
x)	Operation theatres		DB 17 to 27°C RH 45 to 55%
xi)	Museums and libraries		DB 20 to 22°C RH 40 to 55%
xii)	Telephone terminal rooms		DB 22 to 26°C RH 40 to 50%



Source: Table-2 of Part 8 Building services – section 3 – Air conditioning, heating and mechanical ventilation of National Building Code – 2005

**6.7.1.2** *Outdoor design conditions*

The outdoor design conditions shall be in accordance with the conditions given in Table 6.19.

Table 6.19: Summary for outdoor conditions Source

Table 3 Summary for Outdoor Conditions (Clause 4.4.4)																
Station (1)	Cooling DB/MCWB						Cooling WB/MCDB						Heating DB/MCWB			
	0.4%		1.0%		2.0%		0.4%		1.0%		2.0%		99.6%		99.0%	
	DB (2)	MCWB (3)	DB (4)	MCWB (5)	DB (6)	MCWB (7)	WB (8)	MCDB (9)	WB (10)	MCDB (11)	WB (12)	MCDB (13)	DB (14)	MCWB (15)	DB (16)	MCWB (17)
Ahmedabad	42.3	24.1	41.2	23.5	40.0	24.3	28.7	34.3	28.2	33.6	27.8	33.1	11.5	9.0	12.9	9.8
Akola	43.4	24.0	42.2	23.3	41.0	23.6	27.6	37.8	26.7	34.4	26.1	33.5	12.7	10.3	13.9	10.6
Allahabad	43.7	23.4	42.2	23.5	40.8	22.7	28.8	33.0	28.4	32.8	28.0	32.6	7.9	7.0	9.1	8.3
Amritsar	41.6	23.2	40.3	24.6	38.9	24.4	29.3	34.8	28.8	34.8	28.4	33.4	2.7	2.3	4.0	3.5
Aurangabad	40.3	22.1	39.3	22.9	38.3	21.3	26.3	36.2	25.3	33.1	24.7	31.4	10.6	8.2	12.0	9.1
Bangalore	34.7	19.6	34.0	19.6	33.1	19.2	23.5	28.9	22.9	28.2	22.5	27.7	14.9	13.0	15.7	13.8
Barmer	43.1	24.2	42.0	23.6	41.0	23.3	28.5	37.9	27.8	35.3	27.2	33.3	9.5	5.1	10.7	5.5
Belgaum	36.5	19.4	35.7	19.6	34.7	19.2	24.3	29.2	23.8	29.5	23.4	28.2	13.2	11.3	14.3	12.2
Bhagalpur	42.4	26.8	40.7	27.4	38.9	25.6	30.0	37.1	29.6	36.4	29.2	35.2	11.4	10.3	12.6	12.4
Bhopal	41.7	22.0	40.5	21.7	39.3	21.3	26.0	31.0	25.6	30.3	25.2	29.9	9.8	6.8	11.0	8.0
Bhubaneshwar	38.9	25.5	37.6	26.6	36.3	26.3	29.4	35.2	28.9	33.3	28.5	32.7	14.4	13.1	15.4	14.0
Bikaner	44.8	22.4	43.4	22.4	42.0	23.1	28.5	34.6	27.9	33.1	27.3	34.7	3.8	2.2	5.3	3.1
Chennai	38.4	26.2	37.3	26.7	36.3	26.4	29.1	33.8	28.6	33.2	28.1	31.9	19.5	20.2	18.7	19.3
Chitradurg	36.6	18.8	35.8	19.0	35.0	19.6	23.9	28.9	23.5	28.2	23.2	28.5	15.4	12.5	16.4	13.3
Dehradun	37.8	23.5	36.3	23.9	34.8	22.8	27.0	31.3	26.5	30.1	26.0	29.8	5.9	5.0	6.8	5.8
Dibrugarh	34.0	27.4	33.2	26.8	32.3	26.7	28.3	32.6	27.8	31.8	27.4	31.3	7.5	7.2	8.7	8.4
Gorakhpur	41.4	26.2	40.3	26.0	39.1	26.4	29.9	35.2	29.7	35.5	29.4	34.7	7.9	7.5	9.0	8.4
Guwahati	34.4	26.9	33.4	27.3	32.7	26.8	28.8	32.4	28.3	31.8	27.9	31.5	10.2	9.8	11.3	10.8
Gwalior	43.9	23.0	42.5	22.9	41.3	23.5	27.9	32.9	27.6	32.4	27.3	32.7	4.9	3.8	6.4	5.3
Hissar	44.7	26.5	43.3	25.8	41.7	27.9	30.1	40.2	29.9	39.0	29.4	36.8	5.0	4.2	6.1	5.2
Hyderabad	40.4	22.5	39.2	22.5	38.2	22.4	25.6	33.7	25.2	32.4	24.8	32.0	14.4	12.4	15.5	12.9
Imphal	31.1	23.3	30.2	23.5	29.6	22.9	25.0	29.5	24.6	28.6	24.3	28.3	3.9	3.6	5.0	4.6
Indore	41.1	20.7	40.4	20.6	38.9	21.0	25.7	31.0	25.2	30.0	24.8	29.8	8.2	5.0	9.7	6.5
Jabalpur	42.6	22.7	41.2	23.2	39.8	22.5	26.8	31.8	26.4	32.0	26.0	31.2	7.8	6.7	9.3	7.6
Jagdelpur	39.4	22.3	38.6	22.5	37.4	22.4	26.4	32.4	25.9	31.8	25.4	30.7	8.9	7.9	10.1	8.7
Jaipur	42.8	22.5	41.4	22.6	39.4	22.6	27.4	33.1	27.0	32.1	26.6	31.7	6.4	4.5	8.0	5.8
Jaisalmer	43.7	23.7	42.5	23.1	41.4	23.5	27.7	34.8	27.3	34.5	26.9	34.4	5.0	2.5	6.5	3.7
Jamnagar	37.1	24.4	36.1	25.6	35.3	25.1	29.2	33.0	28.4	32.5	27.9	32.0	10.0	8.6	11.7	10.5
Jodhpur	42.0	23.2	40.8	23.0	39.6	22.7	28.0	35.4	27.4	33.7	26.9	33.8	7.5	4.3	8.7	5.4
Jorhat	34.4	28.2	33.6	27.7	32.9	27.3	28.7	32.7	28.3	32.1	28.0	31.8	9.6	9.0	10.6	10.1
Kolkata	37.2	25.4	36.2	26.1	35.2	26.5	29.5	34.3	29.0	33.4	28.6	32.7	12.0	10.9	13.1	12.9
Kota	43.5	23.0	42.4	22.6	41.2	22.6	27.3	35.2	26.8	33.0	26.5	31.8	9.9	6.7	10.8	7.6
Kurnool	41.6	23.2	40.3	24.6	38.9	24.4	29.3	34.8	28.8	34.8	28.4	33.4	2.7	2.3	4.0	3.5
Lucknow	42.0	24.2	40.8	24.8	39.3	24.5	28.8	33.3	28.4	32.4	28.0	32.2	7.5	6.8	8.4	7.7
Mangalore	33.9	24.4	33.9	24.0	33.4	24.2	27.1	31.0	26.7	31.0	26.4	30.7	19.7	17.0	20.5	18.1
Mumbai	35.3	22.8	34.3	23.3	33.5	24.0	27.9	31.8	27.5	31.3	27.2	31.1	16.5	13.9	17.8	14.8
Nagpur	43.8	23.6	42.6	23.9	41.4	23.6	27.3	31.2	26.6	33.2	26.2	31.9	11.5	9.4	12.8	10.2
Nellore	40.4	27.8	39.0	28.1	37.8	27.2	30.0	37.1	29.4	35.4	28.8	34.0	19.4	18.3	20.2	19.3
New Delhi	41.8	23.6	40.6	23.8	39.4	23.5	28.4	33.3	28.0	33.3	27.6	32.7	6.0	5.2	7.1	6.3
Panjim	34.0	24.8	33.5	25.2	33.0	25.2	27.7	32.3	27.4	31.5	27.0	30.9	19.6	17.8	20.3	18.7
Patna	40.7	23.4	39.5	23.7	38.0	24.7	29.0	33.9	28.6	33.1	28.3	32.6	8.0	7.6	9.2	8.6
Pune	38.4	20.5	37.4	20.4	36.3	20.6	24.8	30.9	24.4	30.6	24.0	29.6	9.2	8.0	10.3	9.2
Raipur	43.6	23.3	42.2	23.3	40.8	23.0	27.1	31.8	26.8	32.0	26.5	31.2	11.3	9.9	12.6	10.4
Rajkot	40.8	23.1	39.9	23.8	38.9	23.4	28.1	33.9	27.6	33.3	27.1	32.3	10.9	6.5	12.2	7.7
Ramagundam	43.4	25.6	42.2	25.1	40.7	25.8	28.3	37.3	27.9	35.6	27.4	34.4	12.5	11.2	13.7	12.5
Ranchi	38.9	22.1	37.7	21.8	36.4	21.5	26.2	31.7	25.6	30.4	25.2	29.2	9.1	7.2	10.4	8.3
Ratnagiri	34.1	22.4	33.4	23.2	32.8	23.6	27.6	31.1	27.3	30.8	27.0	30.2	18.3	14.9	19.2	16.5
Raxaul	38.6	23.1	36.9	24.5	35.5	24.6	28.9	33.0	28.4	32.0	28.1	31.8	7.5	7.3	8.5	8.2
Saharanpur	41.3	23.8	39.6	24.6	38.1	24.0	28.5	33.6	28.1	32.9	27.8	32.5	1.7	1.5	3.0	2.7
Shillong	24.2	19.7	23.5	19.4	22.8	18.9	20.7	23.3	20.3	22.7	19.9	22.2	-1.0	-1.1	0.1	-0.5
Sholapur	41.1	21.6	40.1	21.6	39.1	21.2	26.6	32.6	25.8	32.1	25.1	31.5	16.3	12.4	17.2	12.5
Sundernagar	36.1	19.1	34.6	19.9	33.1	19.4	25.2	30.1	24.8	29.2	24.4	28	1.8	1.3	2.8	2.2
Surat	38.4	22.7	36.9	23.9	35.7	23.4	28.3	32.4	27.9	31.7	27.6	31.4	14.8	12.6	16.2	12.5
Tezpur	34.2	27.4	33.3	26.5	32.5	27.1	28.9	32.8	28.4	31.8	28.0	31.4	10.5	10.0	12.4	10.9
Tiruchirapalli	39.6	24.6	38.7	25.1	37.8	24.9	27.7	34.5	27.2	33.7	26.9	33.3	19.3	18.2	20.1	18.7
Thiruvananthapuram	33.9	26.0	33.4	26.1	32.9	25.9	27.7	32.4	27.4	31.9	27.0	31.0	21.6	20.1	22.2	20.8
Veraval	35.2	23.9	33.8	23.5	32.8	26.6	29.1	32.3	28.7	31.6	28.4	31.1	14.3	10.1	15.6	12.3
Visakhapatnam	36.4	26.5	35.6	27.3	35.0	27.1	29.2	33.8	28.8	33.0	28.4	32.5	15.4	14.9	16.8	16.2

NOTE — Abbreviations used:  
 DBT — Dry-bulb temperature  
 WBT — Wet-bulb temperature  
 MCDB — Mean coincidental dry-bulb temperature  
 MCWB — Mean coincidental wet-bulb temperature.

Source : Table-3 of Part 8 Building services – section 3 – Air conditioning, heating and mechanical ventilation of National Building Code – 2005

- Values of ambient dry-bulb and wet-bulb temperatures against the various annual percentiles represent the value that is exceeded on average by the indicated percentage of the total number of hours.
- The 0.4 %, 1.0% and 2.0% values are exceeded on average 35, 88 and 175 hours in a year.
- The 99.0% percent and 99.6 percent values are defined in the same way but are usually reckoned as the values for which the corresponding temperatures are less than the design conditions for 88hours and 35 hours.
- For normal comfort jobs values in 1% column should be used for cooling loads and 99% column for heating loads.
- For critical applications values in 0.4% column should be used for cooling loads and 99.6% column for heating loads.

#### *6.7.1.3 Minimum outside fresh air*

The fresh air supply is required to maintain good indoor air quality. The minimum fresh air required in a mechanically ventilated or air conditioned spaces should be as recommended in Table 6.20.

Table 6.20: Minimum air requirements for ventilation of all common areas and commercial facilities

Sl No.	Application	Estimated Maximum Occupancy Persons/100 m <sup>2</sup>	Outdoor Air Requirement		Remarks
			l/s/Person	(l/s)/m <sup>2</sup>	
(1)	(2)	(3)	(4)	(5)	(6)
i)	<b>Commercial dry cleaner</b>	30	15		
ii)	<b>Food and Beverage Service</b>				
	Dining rooms	70	10		
	Cafeteria, fast food	100	10		
	Bars, cocktail lounges	100	15		Supplementary smoke removal equipment may be required.
	Kitchen (cooking)	20	8		Make up air for food exhaust may require more ventilating air. The sum of the outdoor air and transfer air of acceptable quality from adjacent spaces shall be sufficient to provide an exhaust rate of not less than 27.5 m <sup>3</sup> /h.m <sup>2</sup> (7.5 l/s.m <sup>2</sup> ).
iii)	<b>Hotels, Motels, Resorts, Dormitories</b>				Independent of room size.
	Bedrooms		15		
	Living rooms			15	
	Baths			18	Installed capacity for intermittent use.
	Lobbies	30	8		
	Conference rooms	50	10		
	Assemble rooms	120	8		
	Dormitory sleeping areas	20	8		See also food and beverage services, merchandising, barber and beauty shops, garages, offices. Some office equipment may require local exhaust.
	Office space	7	10		
	Reception areas	60	8		
	Telecommunication centers and data entry areas	60	10		
	Conference rooms	50	10		
iv)	<b>Public Spaces</b>				
	Corridors and utilities			0.25	
	Public restrooms, l/s/wc or urinal		25		Normally supplied transfer air.
	Locker and dressing rooms			2.5	Local mechanical exhaust with no re-circulation recommended.
	Elevators			5.0	Normally supplied by transfer air.
	Retail stores, sales floors and show room floors				
	Basement and street	30		1.50	
	Upper floors	20		1.00	
	Storage rooms	15		0.75	
	Dressing rooms			1.00	
	Malls and arcades	20		1.00	
	Shipping and receiving	10		0.75	
	Warehouses	5		0.25	
	Smoking lounge	70	30		Normally supplied by transfer air, local mechanical exhaust; exhaust with no re-circulation recommended.
v)	<b>Specialty Shops</b>				
	Barber Shop	25	8		
	Beauty Parlour	25	13		
	Florists	8	8		Ventilation to optimize growth may dictate requirements.
	Clothiers, furniture			1.50	
	Hardware, drugs, fabric	8	8		
	Supermarkets	8	8		
	Pet shops			5.00	
vi)	<b>Sports and Amusement</b>				
	Spectator areas	150	8		When internal combustion engines are operated for maintenance of playing surfaces, increased ventilation rates may be required.
	Game rooms	70	13	2.50	
	Ice arenas (playing areas)				

<b>Table 4 — Concluded</b>					
(1)	(2)	(3)	(4)	(5)	(6)
	Swimming pools (pool and deck area)			2.50	Higher values may be required for humidity control.
	Playing floors (gymnasium)	30	10		
	Ballrooms and discos	100	13		
	Bowling alleys (seating area)	70	13		
vii)	<b>Theatre</b>				
	Ticket booths	60	10		Special ventilation will be needed to eliminate special stage effects (for example, dry ice vapours, mists, etc).
	Lobbies	150	10		
	Auditorium	150	8		
	Stages, studios	70	8		
viii)	<b>Transportation</b>				
	Waiting rooms	100	8		Ventilation within vehicles may require special consideration.
	Platforms	100	8		
	Vehicles	150	8		
ix)	<b>Workrooms</b>				
	Meat processing	10	8		Spaces maintained at low temperature at (-10°F to + 50°F or -23°C to + 10°C) are not covered by these requirements unless the occupancy is continuous. Ventilation from adjoining spaces is permissible. When the occupancy is intermittent, infiltration will normally exceed the ventilation requirement.
	Photo studios	10	8		
	Darkrooms	10	8	2.50	
	Pharmacy	20	8		
	Bank vaults	5	8		2.50 Installed equipment shall incorporate positive exhaust and control (as required) of undesirable contaminants (toxic and otherwise).
	Duplicating, printing				
x)	<b>Education</b>				
	Classrooms	50	8		Special contaminant control systems may be required for processes or functions including laboratory animal occupancy.
	Laboratories	30	10		
	Training shop	30	10		
	Music rooms	50	8		
	Libraries	20	8		
	Locker rooms			2.50	
	Corridors			0.50	
	Auditoriums	150	8		
xi)	<b>Hospital, Nurses and Convalescent Homes</b>				
	Patient rooms	10	13		Special requirements or codes provisions and pressure relationships may determine minimum ventilation rates and filter efficiency.
	Medical procedure	20	8		
	Operating rooms	20	15		
	Procedure Recovery and ICU		20	8	Generating contaminants may require higher rates.
	Autopsy			2.50	Air shall not be re-circulated into other spaces.
	Physical therapy	20	8		
	Correctional Cells	20	10		
	Dining halls	100	8		
	Guard stations	40	8		

<sup>1)</sup> This table prescribes supply rates of acceptable outdoor air required for acceptable indoor air quality. These values have been chosen to dilute human bioeffluents and other contaminants with an adequate margin of safety and to account for health variations among people and varied activity levels.

<sup>2)</sup> Net occupiable space.

Source: Table-4 Part 8 Building Services – Section 3 – Air conditioning, heating and mechanical ventilation of National Building Code – 2005.

## 6.7.2 Green Refrigerant

Refrigerant used in all air-conditioning machines should be CFC free as per India's commitment to Montreal protocol.

## 6.7.3 Minimum equipment efficiencies

### 6.7.3.1 Cooling & heating equipment

All cooling & heating equipment shall meet or exceed the minimum efficiency requirements presented in Tables 6.21 to 6.25 (Source: Draft of energy conservation building code-2006 of Bureau of Energy Efficiency).

Table 6.21: Unitary air conditioning equipment

S No.	Equipment Class	Minimum COP	Minimum IPLV	Test Standard
1	Unitary Air Cooled Air Conditioner $\geq 19$ and $< 40$ kW ( $\geq 5.4$ and $< 11$ tons)	3.08		ARI 210/240
2	Unitary Air Cooled Air Conditioner $\geq 40$ to $< 70$ kW ( $\geq 11$ to $< 20$ tons)	3.08		ARI 340/360
3	Unitary Air Cooled Air Conditioner $\geq 70$ kW ( $\geq 20$ tons)	2.93	2.99	ARI 340/360
4	Unitary Water Cooled Air Conditioner $< 19$ kW ( $< 5.4$ tons)	4.1		ARI 210/240
5	Unitary Water Cooled Air Conditioner $\geq 19$ and $< 40$ kW ( $\geq 5.4$ and $< 11$ tons)	4.1		ARI 210/240
6	Unitary Water Cooled Air Conditioner $\geq < 40$ kW ( $\geq 11$ tons)	3.22	3.02	ARI 210/240

Table 6.22: Chillers

S No.	Equipment Class	Minimum COP	Minimum IPLV	Test Standard
1	Air Cooled Chiller $< 530$ kW ( $< 150$ tons)	2.9	3.16	ARI 550/590-1998
2	Air Cooled Chiller $\geq 530$ kW ( $\geq 150$ tons)	3.05	3.32	ARI 550/590-1998
3	Centrifugal Water Cooled Chiller $< 530$ kW ( $< 150$ tons)	5.8	6.09	ARI 550/590-1998
4	Centrifugal Water Cooled Chiller $\geq 530$ and $< 1050$ kW ( $\geq 150$ and $< 300$ tons)	5.8	6.17	ARI 550/590-1998
5	Centrifugal Water Cooled Chiller $\geq 1050$ kW ( $\geq 300$ tons)	6.3	6.61	ARI 550/590-1998
6	Reciprocating Compressor, Water Cooled Chiller all sizes	4.2	5.05	ARI 550/590-1998
7	Rotary Screw and Scroll Compressor, Water Cooled Chiller $< 530$ kW ( $< 150$ tons)	4.7	5.49	ARI 550/590-1998
8	Rotary Screw and Scroll Compressor, Water Cooled Chiller $\geq 530$ and $< 1050$ kW	5.4	6.17	ARI 550/590-1998

S No.	Equipment Class (≥150 and <300 tons)	Minimum COP	Minimum IPLV	Test Standard
9	Rotary Screw and Scroll Compressor, Water Cooled Chiller ≥ 1050 kW (≥ 300 tons)	5.75	6.43	ARI 550/590-1998

Table 6.23: Heating pumps heating mode

S No.	Equipment type	Size Category (Input)	Subcategory or rating condition	Performance required	Test procedure
1	Air Cooled (Heating Mode)	<19 kW (Cooling Capacity)	Split System	6.8 HSPF (before 1/23/2006) 7.4 HSPF (as of 1/23/2006)	ARI 210/240
			Single Package	6.6 HSPF (before 1/23/2006) 7.4 HSPF (as of 1/23/2006)	
2	Air Cooled (Heating Mode)	≥19 kW and <40 kW (Cooling Capacity)	8°C db/6°C wb Outdoor air	3.2 COP	ARI 340/360
			-8°C db/-9°C wb Outdoor Air	2.2 COP	
		≥40 kW (Cooling Capacity)	8°C db/6°C wb Outdoor air	3.1 COP	
			-8°C db/-9°C wb Outdoor Air	2.0 COP	

Table 6.24: Furnaces

S No.	Equipment type	Size Category (Input)	Subcategory or rating condition	Performance required	Test procedure
1	Warm Air Furnace, Gas-Fired	<66 kW		78% AFUE or 80% Et d	DOE 10 CFR  Part 430 or ANSI Z21.47
		≥66 kW	Maximum Capacity	80% Ec c	ANSA Z21.47
2	Warm Air Furnace, Oil-Fired	<66 kW		78% AFUE or 80% Et d	DOE 10 CFR  Part 430 or ANSI Z21.47
		≥66 kW	Maximum Capacity	81% Et f	UL 727
3	Warm- Air Duct	All Capacities	Maximum Capacity	80% Ec g	ANSI Z83.9

S No.	Equipment type	Size Category (Input)	Subcategory or rating condition	Performance required	Test procedure
	Furnaces, Gas-Fired				
4	Warm Air Unit Heaters, Gas-Fired	All Capacities	Maximum Capacitye	80% Ec g	ANSI Z83.8
5	Warm Air Unit Heaters, Oil-Fired	All Capacities	Maximum Capacitye	80% Ec g	UL 731

Table 6.25: Boilers

S No.	Equipment type	Size Category (Input)	Subcategory or rating condition	Performance required	Test procedure
1	Boilers, Gas-Fired	<88 kW	Hot Water	80% AFUE	DOE 10 CFR Part 430
			Steam	75% AFUE	
		≥88 kW and ≤733 kW	Maximum Capacityd	75% Et b	H.I. Htg Boiler Std.
			Hot Water	80% Ec	
			Steam	80% Ec	
2	Boilers, Oil-Fired	<88 kW		80% AFUE	DOE 10 CFR Part 430
			Maximum Capacityd	78% Et b	H.I. Htg Boiler Std.
		≥88 kW and ≤733 kW	Hot Water	83% Ec	
			Steam	83% Ec	
			Maximum Capacityd	78% Et b	H.I. Htg Boiler Std.
3	Oil-Fired (Residual)	≥88 kW and ≤733 kW	Hot Water	83% Ec	
			Steam	83% Ec	
		>733 kW	83% Ec		

#### 6.7.4 Controls

- All mechanical cooling and heating systems shall be controlled by a timer that:
  - a. Can start and stop the system under different schedules for three different day-types per week,
  - b. Is capable of retaining programming and time setting during a loss of power for a period of at least 10 hours, and
  - c. Includes an accessible manual override that allows temporary operation of the system for up to 2 hours.
  - d. However cooling systems < 28 kW (8 tons) and Heating systems < 7 kW (2 tons) are not included
- All heating and cooling equipment shall be temperature controlled. Where a unit provides both



heating and cooling, controls shall be capable of providing a temperature dead band of 3°C (5°F) within which the supply of heating and cooling energy to the zone is shut off or reduced to a minimum. Where separate heating and cooling equipment serve the same temperature zone, thermostats shall be interlocked to prevent simultaneous heating and cooling.

- All cooling towers and closed circuit fluid coolers shall have either two speed motors, pony motors, or variable speed drives controlling the fans.

#### 6.7.5 Piping & ductwork

- Piping for heating systems with a design operating temperature of 60°C (140°F) or greater shall have at least R-0.70 (R-4) insulation. Piping for heating systems with a design operating temperature less than 60°C (140°F) but greater than 40°C (104°F), piping for cooling systems with a design operating temperature less than 15°C (59°F), and refrigerant suction piping on split systems shall have at least R-0.35 (R-2) insulation. Insulation exposed to weather shall be protected by aluminum sheet metal, painted canvas, or plastic cover. Cellular foam insulation shall be protected as above, or be painted with water retardant paint.
- Ductwork shall be insulated in accordance with requirement of ECBC-2006 of BEE which is also reproduced below in Table 6.27.

Table 6.26: Ductwork Insulation

Required Insulation <sup>a</sup>		
Duct Location	Supply Ducts	Return Ducts
Exterior	R-1.4 (R-8)	R-0.6 (R-3.5)
Ventilated Attic	R-1.4 (R-8)	R-0.6 (R-3.5)
Unventilated Attic without Roof Insulation	R-1.4 (R-8)	R-0.6 (R-3.5)
Unventilated Attic with Roof Insulation	R- 0.6 (R-3.5)	No Requirement
Unconditioned Space <sup>b</sup>	R- 0.6 (R-3.5)	No Requirement
Indirectly Conditioned Space <sup>c</sup>	No Requirement	No Requirement
Buried	R- 0.6 (R-3.5)	No Requirement

<sup>a</sup> Insulation R-value is measured on a horizontal plane in accordance with ASTM C518 at a mean temperature of 24°C (75°F) at the installed thickness

<sup>b</sup> Includes crawlspaces, both ventilated and non-ventilated

<sup>c</sup> Includes return air plenums with or without exposed roofs above.

### 6.7.6 Variable flow hydronic systems

Chilled or hot-water systems shall be designed for variable fluid flow and shall be capable of reducing pump flow rates to no more than the larger of:

- (a) 50% of the design flow rate, or
- (b) The minimum flow required by the equipment manufacturer for proper operation of the chillers or boilers.

Water cooled air-conditioning or heat pump units with a circulation pump motor greater than or equal to 3.7 kW (5 hp) shall have two-way automatic isolation valves on each water cooled air-conditioning or heat pump unit that are interlocked with the compressor to shut off condenser water flow when the compressor is not operating.

Chilled water or condenser water systems that must comply with either of above two and that have pump motors greater than or equal to 3.7 kW (5 hp) shall be controlled by variable speed drives.

## 6.8 Electrical system

### 6.8.1 Transformers

#### Maximum Allowable Power Transformer Losses

Power transformers of the proper ratings and design must be selected to satisfy the minimum acceptable efficiency at their full load rating. In addition, the transformer must be selected such that it minimizes the total of its initial cost in addition to the present value of the cost of its total lost energy while serving its estimated loads during its respective life span. Transformers used in buildings shall be constructed with high quality grain oriented low loss silicon steel and virgin electrolytic grade copper and the manufacturer's certificate to this effect shall be obtained.

Table 6.27: Maximum Allowable Losses of 11, 22 kV Transformers

S No.	Transformer capacity (kVA)	Maximum allowable losses at full load in % of rating in 11kV transformer	Maximum allowable losses at full load in % of rating in 22 kV transformer
1	100	2.5	2.7
2	160	2.3	2.2
3	250	2.1	1.8
4	400	1.5	1.5
5	630	1.4	1.5
6	800	1.4	1.5
7	1000	1.2	1.2

Reference conditions: 100% of nameplate load at temperature of 75o C

## 6.8.2 Energy Efficient Motors

Motors shall comply with the following:

- All permanently wired polyphase motors of 0.375 kW or more serving the building and expected to operate more than 1,500 hours per year and all permanently wired polyphase motors of 50kW or more serving the building and expected to operate more than 500 hours per year shall have a minimum acceptable nominal full load motor efficiency not less than shown in Table 6.28 or the BIS for energy efficient motors.
- Motors of horsepower differing from those listed in the table shall have efficiency greater than that of the next listed kW motor.
- Motor horsepower ratings shall not exceed 200% of the calculated maximum load being served.
- Motor nameplates shall list the nominal full-load motor efficiencies and the full-load power factor.
- Motor users should insist on proper rewinding practices for any rewind motors. If the proper rewinding practices cannot be assured, the damaged motor should be replaced with a new, efficient one rather than suffer the significant efficiency penalty associated with typical rewind practices.
- Certificates shall be obtained and kept on record indicating the motor efficiency. Whenever a motor is rewind, appropriate measures shall be taken so that the core characteristics of the motor is not lost due to thermal and mechanical stress during removal of damaged parts. After rewinding, a new efficiency test shall be performed and a similar record shall be maintained.

Table 6.28 : Minimum acceptable motor efficiencies

S No.	Motor size (kiwi)	2-pole motor efficiency	4-pole motor efficiency
1	1.1 (1.5 hp)	82.2	83.8
2	1.5 (2 hp)	84.1	85
3	2.2 (3 hp)	85.6	86.4
4	3.0 (4 hp)	86.7	87.4
5	4.0 (5.5 hp)	87.6	88.3
6	5.5 (7.5 hp)	88.5	89.2
7	7.5 (10 hp)	89.5	90.1
8	11.0 (15 hp)	90.6	91
9	15.0 (20 hp)	91.3	91.8
10	18.5 (25 hp)	91.8	92.2
11	22.0 (30 hp)	92.2	92.6
12	30.0 (40 hp)	92.9	93.2
13	37.0 (50 hp)	93.3	93.6
14	45.0 (60 hp)	93.7	93.9
15	55.0 (75 hp)	94	94.2
16	75.0 (100 hp)	94.6	94.7

### 6.8.3 Power Factor Correction

All electricity supplies exceeding 100 A, 3 phase shall maintain their power factor between 0.98 lag and unity at the point of connection.

### 6.8.4 Diesel generator Captive Power Plants

The specific fuel consumption (lit/kWh) of diesel generating sets shall not exceed the values given in table below.

Table 6.29 Recommended specific fuel consumption of DG sets

S No.	Electricity generating capacity (kW)	Type of fuel used	Specific fuel consumptions (lit/kWh)
1	200	HSD	0.325
2	292	LDO	0.335
3	400	HSD	0.334
4	480	LDO	0.334
5	800	HSD	0.29
6	880	LDO	0.307
7	920	LDO	0.297

Use turbochargers along with diesel generating sets. With the arrival of modern, high efficiency turbochargers, it is possible to use an exhaust gas driven turbine generator to further increase the engine rated output. This results in lower fuel consumption per kWh and further increases in overall thermal efficiency.

### 6.8.5 Check-Metering and Monitoring

- Buildings whose maximum demand is greater than 250 kVA shall have the electrical distribution system with their energy consumption being check-metered.
- Services exceeding 1000 kVA shall have permanently installed electrical metering to record demand (kVA), energy (kWh), and total power factor. The metering shall also display current (in each phase and the neutral), voltage (between phases and between each phase and neutral), and total harmonic distortion (THD) as a percentage of total current.
- Services not exceeding 1000 kVA but over 65 kVA shall have permanently installed electric metering to record demand (kW), energy (kWh), and total power factor (or kVARh).
- Services not exceeding 65 kVA shall have permanently installed electrical metering to record energy (kWh).

### 6.8.6 Power Distribution Systems

All the power junction boxes and main power distribution board and cable termination points shall be provided with temperature monitoring mechanism comprising of sensors in the enclosed chambers and properly visible temperature indicators outside. Record of temperature during commissioning and subsequently on a daily basis shall be maintained.

The power cabling shall be adequately sized as to maintain the distribution losses not to exceed 1% of the total power usage. Record of design calculation for the losses shall be maintained.

### Reference

1. National Building Code, 2005
2. Energy Conservation Building Code, 2005
3. Guide to Sustainable Building Design, Ministry of Non-conventional Energy sources, Government of India



## Annexure I Mandatory and expected criteria

### Mandatory criteria

#### Sustainable Site Planning

##### *Site Selection*

- Land Use- The land use in the site should be as per Master Plan / Local Development Plan. If the Master plan is not available then UDPFI(Urban Development and Plans Formulation and Implementation) guidelines should be followed.
- Ambient environment quality- The project design shall ensure that the occupants of sites where the environment is already polluted are safeguarded against the adversities. Pre construction air, water and noise quality shall be monitored and it shall be ensured that the ambient environment quality is minimally impacted upon by the proposed construction. The governing standards for air, water and noise are as below:
  - Air quality standards as per IS-5182,
  - Drinking water standards as per IS: 10500-1991
  - Construction water standards as per CPWD Specifications
  - Ambient noise standards as per Central Pollution Control Board (CPCB)
- The proponent shall also take suitable measures to ensure improvement of environmental quality (if the ambient standards are not met) through suitable mitigation measures .
- Infrastructure- There must be a justification and proof of the availability of water, energy, waste disposal and transport network for the sustainability of the project.

##### *Site Analysis and planning*

- Site Planning- Site planning must have consideration for efficient utilization of existing resources, i.e., the sunlight, wind etc. It must be ensured that solar access and wind access to neighbouring developments is minimally impacted upon due to the proposed construction.
- Analysis should be carried out to ensure that there is adequate solar and wind access for the proposed buildings
- Conservation of soil – Fertility of top soil shall be tested to check appropriateness of top soil preservation and re use. This test is mandatory for sites having area more than 1000

hectares. If suitable, preservation and re use of top soil should be done, as per National building code 2005.

- Landscaping- The existing landscape (e.g mature trees) must be preserved to the extent feasible, during construction and during use . Sustainable landscape practices should be adopted to ensure erosion and sedimentation control, storm water management, minimized heat island effects and water conservation. Attempt shall be made to minimally disrupt natural site features e.g landforms, contours etc.
- Health and well being of construction workers- Minimum level of hygiene must be maintained over the site by providing the basic services in terms of safe drinking water supply, sanitation facilities, etc. Construction safety norms as recommended by National building Code shall 2005 be followed.

#### Water Demand Management

##### *Building (Internal) Demand Management*

- Water availability: Water demand for the building (internal use only) shall not exceed limits as defined by the National Building Code 2005.
- Quality of water – The water quality for drinking purposes shall meet standards defined by IS 10500-1991 and water quality for other uses shall meet CPCB standards.
- Fixtures – Low flow/ dual flushing devices should be used for water closets.

##### *Landscape water quality*

- Quality of water – Quality of water for gardening should meet quality standards as per IS 11624-1986

##### *Wastewater*

- Separation of grey and black water- Separation of grey and black water must be done by the use of dual plumbing line for separation of grey and black water .
- Treatment- The treated waste water shall meet with CPCB standards for discharge. The grey and black water must be piped in separate line and there must be 100 per cent treatment of grey water and re use for flushing , gardening etc.

##### *Rainwater harvesting*

- Storm /rain water control and re use is mandatory and the system must be as per Central Ground Water Board (CGWB) and Bureau of Indian Standards (BIS standards) for reuse in various applications.



## Managing Transport, Noise and Air

### *Transportation (Internal) Plan*

#### *Hierarchy of Road*

The road pattern and hierarchy must meet with the standards as recommended by Indian Road Congress (IRC)

#### *Traffic Calming measures*

Traffic calming measures must be taken in all the sensitive zones to reduce noise and air pollution, and to improve safety.

- Safety for vulnerable road users- The traffic system must be made safe for vulnerable road users by providing footpath, bicycle track, foot- over bridges and subways and ramps. Traffic system must be accessible and usable for people with disability.
- Entry and exit design – The entry and exit to the site should be designed with precision so as to ensure that the development does not disturb traffic on adjoining/abutting Street.
- Parking norms- The metropolitan cities in India must follow the Parking policy as defined by latest master plan for Delhi. The other cities should follow the norms given in the NBC, i.e., National Building Code 2005 / UDPFI Guidelines/local building bye laws , whichever is higher.

#### *Site Transportation (During construction/ demolition)*

- Norms for Emission- Construction equipment and heavy duty vehicles must conform to pollution norms as per CPCB. Adequate measures to reduce air and noise pollution during construction should be taken. CPCB norms and standards should be followed in this aspect.

## Waste Management

### *Construction and Demolition Waste*

- Onsite Provisions- There must be adequate space for separate storage of waste on construction site. Along with this, on site pre processing of collected waste through grinding and pulverising must be given adjoining to the storage areas.

### *Municipal Waste*

- Storage facilities- There must be provision for separate collection and segregation of household waste, waste from offices and landscape waste in the form of three-bin system in houses. Community level space for separate dustbins as per land use pattern and class of city should be provided
- Disposal- Suitable waste disposal technique should be planned and implemented.

### *Hazardous Waste*

- Storage facility- There must be a permanent and durable space for collection and disposal of paints, asbestos dust and other hazardous wastes.

### *E-waste*

- Storage facility- E-waste is generated occasionally, so there must be provision for its storage at community or group level. Depending upon the office type, the developer or owner must make a long time contract with the manufacturer of electronic items supplier or the recycling industry for sending the wastes. Architectural design must include the space for storage of e-waste, according to the type of office, and e-product usage.

### Energy conservation

#### *Solar Passive Architecture*

- Strategies- The climatic zones have been defined by the National Building Code 2005. Passive strategies as required in the specific climatic zone should be applied.
- Day lighting- BIS standards for daylighting design should be followed.

#### *Building Envelope requirement*

- Roof design- Roof should meet prescriptive requirement as per Energy Conservation Building Code (download from [www.bee-nic.in](http://www.bee-nic.in)) by using appropriate thermal insulation material to fulfil requirement.
- Walls- Opaque wall should meet prescriptive requirement as per Energy Conservation Building Code, which is mandatory for all air-conditioned spaces. Vertical fenestration should comply with the maximum area weighted U-factor as per Energy Conservation Building Code which is mandatory for all air-conditioned spaces.
- Vertical fenestration - Vertical fenestration should comply with maximum area weighted SHGC requirements to meet prescriptive requirement as per Energy Conservation Building Code by use of appropriate solar control strategies.
- Skylights – Skylights shall comply with the maximum U-factor and maximum SHGC requirements to meet prescriptive requirement as per Energy Conservation Building Code by use of efficient glazing material to reduce heat gain through skylight
- Glazing- For all day use buildings glazing products must have the minimum visual transmittance (VT), defined as function of WWR, where Effective Aperture >0.1, equal to or greater than the Minimum VT requirements and to meet

prescriptive requirement as per Energy Conservation Building Code

#### *Building Lighting Demand Management*

- Lighting load- Lighting load must not exceed the specified light power densities (for the specific building type or space function) as per Energy conservation Building Code . Use of energy efficient lamps, luminaries and electronic ballasts is recommended to achieve the desirable LPDs
- Lighting equipment for common areas - Energy efficient lamps (e.g compact Fluorescent Lamps (CFL) or energy efficient tube lights which use electronic ballasts) should be used for internal, Common Area and Exterior Lighting.
- Day lighting controls- Use of maximum day lighting is mandatory for day use buildings by day linking lights in day lit areas (by use of daylight sensors) to avail energy savings.
- Lighting level- Minimum level of lighting should be maintained as per NBC 2005.

#### *Water heating*

- Service water heating by use of renewable energy sources (e.g solar) should be done as per Energy Conservation building Code

#### *Building HVAC system*

- Ventilation- Minimum ventilation rate in the building for heat load estimation should be maintained as specified by National Building Code2005
- Refrigerant- Refrigerant used in air conditioning machines must be as per India's commitment to Montreal protocol
- Equipments- Cooling & heating equipment must conform to minimum efficiency requirement as per the Energy Conservation Building Code.

#### *Building Electrical System*

- Power loss in transformers- Power loss in transformers should be minimized as per Energy Conservation Building Code by use of transformers constructed with high quality grain oriented silicon steel and virgin electrolytic grade copper
- Electric motors- Electric motors must ensure the standards given by Energy conservation Building Code by use of energy efficient motors.
- Power factor- Power factor must be maintained as per Energy conservation Building Code by use of auto power factor correction relays.
- D.G. Sets- Diesel generating sets must meet the norms of CPCB. Suitable stack heights shall be provided as recommended by the CPCB.

## Expected Criteria for Environmental Grading

<b>(1) Site Planning</b>	-		<b>10</b>
1) Orientation, excavation/filling	-		2
2) Landscape, open spaces and parks	-		3
3) Circulation and parking	-		2
4) Social acceptability	-		3
<b>(2) Management of Water</b>	-		<b>20</b>
1) Adequate and suitable source	-		4
2) Management of Demand	-		4
3) Recycling of treated waste water	-		4
4) Rain water Harvesting – quantity & safeguard-			4
5) Collection, treatment and disposal of waste water-			4
<b>(3) Building Materials</b>	-		<b>10</b>
1) Use of local materials & construction techniques-			3
2) Use of fly ash and other industrial wastes	-		4
3) Use of less energy intensive materials	-		3
<b>(4) Management of Energy</b>	-		<b>20</b>
1) Energy consumption per sq.m. of area	-		5
2) Use of energy saving materials (min. use Of Glass)	-		5
3) Insulation to achieve ECBC norms	-		5
4) Use of solar energy for lighting and hot water systems.	-		5
<b>(5) Renewable Energy Technology</b>	-		<b>10</b>
1) Use of alternate energy	-		5
* wind mill			
* energy through waste			
2) passive solar architectural features	-		5
<b>(6) Management of Storm Water</b>	-		<b>10</b>
1) Obstruction to others	-		3
2) Capacity of SW drainage	-		3
3) Outfall and prevention of flooding	-		4
<b>(7) Management of Solid wastes</b>	-		<b>10</b>
1) Biodegradable	-		4
2) Non-biodegradable	-		3
3) Hazardous	-		3

<b>(8) Management of Noise and Odour</b>	-	<b>10</b>
1) Containment of noise & odour	-	3
2) Abatement of noise & odour	-	2
3) Design and lay out of green belt	-	5
<b>TOTAL</b>	-	<b>100</b>

**Grading:**

Platinum	90-100
Gold	80-89
Silver	60-79
Bronze	40-59

Proposals getting less than 40 points will get 0 grading.

Minimum expected grading is as follows:

Eco-sensitive areas and metro cities, NCR and regional development areas of  
 Metros: Gold  
 Other cities with > 1 million populations as per latest available census: Silver  
 Other areas: Bronze



## Annexure II FORM-1 A (only for construction projects listed under item 8 of the Schedule)

### Check List Of Environmental Impacts

(Project proponents are required to provide full information and wherever necessary attach explanatory notes with the Form and submit along with proposed environmental management plan & monitoring programme)

#### 1. Land Environment

(Attach panoramic view of the project site and the vicinity)

- 1.1. Will the existing landuse get significantly altered from the project that is not consistent with the surroundings? (Proposed landuse must conform to the approved Master Plan / Development Plan of the area. Change of landuse if any and the statutory approval from the competent authority be submitted). Attach Maps of (i) site location, (ii) surrounding features of the proposed site (within 500 meters) and (iii) the site (indicating levels & contours) to appropriate scales. If not available attach only conceptual plans.
- 1.2. List out all the major project requirements in terms of the land area, built up area, water consumption, power requirement, connectivity, community facilities, parking needs etc.
- 1.3. What are the likely impacts of the proposed activity on the existing facilities adjacent to the proposed site? (Such as open spaces, community facilities, details of the existing landuse, disturbance to the local ecology).
- 1.4. Will there be any significant land disturbance resulting in erosion, subsidence & instability? (Details of soil type, slope analysis, vulnerability to subsidence, seismicity etc may be given).
- 1.5. Will the proposal involve alteration of natural drainage systems? (Give details on a contour map showing the natural drainage near the proposed project site)
- 1.6. What are the quantities of earthwork involved in the construction activity-cutting, filling, reclamation etc. (Give details of the quantities of earthwork involved, transport of fill materials from outside the site etc.)
- 1.7. Give details regarding water supply, waste handling etc during the construction period.

- 1.8. Will the low lying areas & wetlands get altered? (Provide details of how low lying and wetlands are getting modified from the proposed activity)
- 1.9. Whether construction debris & waste during construction cause health hazard? (Give quantities of various types of wastes generated during construction including the construction labour and the means of disposal)

## 2. Water Environment

- 2.1. Give the total quantity of water requirement for the proposed project with the breakup of requirements for various uses. How will the water requirement met? State the sources & quantities and furnish a water balance statement.
- 2.2. What is the capacity (dependable flow or yield) of the proposed source of water?
- 2.3. What is the quality of water required, in case, the supply is not from a municipal source? (Provide physical, chemical, biological characteristics with class of water quality)
- 2.4. How much of the water requirement can be met from the recycling of treated wastewater? (Give the details of quantities, sources and usage)
- 2.5. Will there be diversion of water from other users? (Please assess the impacts of the project on other existing uses and quantities of consumption)
- 2.6. What is the incremental pollution load from wastewater generated from the proposed activity? (Give details of the quantities and composition of wastewater generated from the proposed activity)
- 2.7. Give details of the water requirements met from water harvesting? Furnish details of the facilities created.
- 2.8. What would be the impact of the land use changes occurring due to the proposed project on the runoff characteristics (quantitative as well as qualitative) of the area in the post construction phase on a long term basis? Would it aggravate the problems of flooding or water logging in any way?
- 2.9. What are the impacts of the proposal on the ground water? (Will there be tapping of ground water; give the details of ground water table, recharging capacity, and approvals obtained from competent authority, if any)
- 2.10. What precautions/measures are taken to prevent the run-off from construction activities polluting land & aquifers? (Give details of quantities and the measures taken to avoid the adverse impacts)



- 2.11. How is the storm water from within the site managed?(State the provisions made to avoid flooding of the area, details of the drainage facilities provided along with a site layout indication contour levels)
- 2.12. Will the deployment of construction labourers particularly in the peak period lead to unsanitary conditions around the project site (Justify with proper explanation)
- 2.13. What on-site facilities are provided for the collection, treatment & safe disposal of sewage? (Give details of the quantities of wastewater generation, treatment capacities with technology & facilities for recycling and disposal)
- 2.14. Give details of dual plumbing system if treated waste used is used for flushing of toilets or any other use.

### 3. Vegetation

- 3.1. Is there any threat of the project to the biodiversity? (Give a description of the local ecosystem with its unique features, if any)
- 3.2. Will the construction involve extensive clearing or modification of vegetation? (Provide a detailed account of the trees & vegetation affected by the project)
- 3.3. What are the measures proposed to be taken to minimize the likely impacts on important site features (Give details of proposal for tree plantation, landscaping, creation of water bodies etc along with a layout plan to an appropriate scale)

### 4. Fauna

- 4.1. Is there likely to be any displacement of fauna- both terrestrial and aquatic or creation of barriers for their movement? Provide the details.
- 4.2. Any direct or indirect impacts on the avifauna of the area? Provide details.
- 4.3. Prescribe measures such as corridors, fish ladders etc to mitigate adverse impacts on fauna

### 5. Air Environment

- 5.1. Will the project increase atmospheric concentration of gases & result in heat islands? (Give details of background air quality levels with predicted values based on dispersion models taking into account the increased traffic generation as a result of the proposed constructions)
- 5.2. What are the impacts on generation of dust, smoke, odorous fumes or other hazardous gases? Give details in relation to all the meteorological parameters.

- 5.3. Will the proposal create shortage of parking space for vehicles? Furnish details of the present level of transport infrastructure and measures proposed for improvement including the traffic management at the entry & exit to the project site.
- 5.4. Provide details of the movement patterns with internal roads, bicycle tracks, pedestrian pathways, footpaths etc., with areas under each category.
- 5.5. Will there be significant increase in traffic noise & vibrations? Give details of the sources and the measures proposed for mitigation of the above.
- 5.6. What will be the impact of DG sets & other equipment on noise levels & vibration in & ambient air quality around the project site? Provide details.

## 6. Aesthetics

- 6.1. Will the proposed constructions in any way result in the obstruction of a view, scenic amenity or landscapes? Are these considerations taken into account by the proponents?
- 6.2. Will there be any adverse impacts from new constructions on the existing structures? What are the considerations taken into account?
- 6.3. Whether there are any local considerations of urban form & urban design influencing the design criteria? They may be explicitly spelt out.
- 6.4. Are there any anthropological or archaeological sites or artefacts nearby? State if any other significant features in the vicinity of the proposed site have been considered.

## 7. Socio-Economic Aspects

- 7.1. Will the proposal result in any changes to the demographic structure of local population? Provide the details.
- 7.2. Give details of the existing social infrastructure around the proposed project.
- 7.3. Will the project cause adverse effects on local communities, disturbance to sacred sites or other cultural values? What are the safeguards proposed?

## 8. Building Materials

- 8.1. May involve the use of building materials with high-embodied energy. Are the construction materials produced with energy efficient processes? (Give details of energy conservation measures in the selection of building materials and their energy efficiency)
- 8.2. Transport and handling of materials during construction may result in pollution, noise & public

- nuisance. What measures are taken to minimize the impacts?
- 8.3. Are recycled materials used in roads and structures? State the extent of savings achieved?
  - 8.4. Give details of the methods of collection, segregation & disposal of the garbage generated during the operation phases of the project.

## 9. Energy Conservation

- 9.1. Give details of the power requirements, source of supply, backup source etc. What is the energy consumption assumed per square foot of built-up area? How have you tried to minimize energy consumption?
- 9.2. What type of, and capacity of, power back-up to you plan to provide?
- 9.3. What are the characteristics of the glass you plan to use? Provide specifications of its characteristics related to both short wave and long wave radiation?
- 9.4. What passive solar architectural features are being used in the building? Illustrate the applications made in the proposed project.
- 9.5. Does the layout of streets & buildings maximise the potential for solar energy devices? Have you considered the use of street lighting, emergency lighting and solar hot water systems for use in the building complex? Substantiate with details.
- 9.6. Is shading effectively used to reduce cooling/heating loads? What principles have been used to maximize the shading of Walls on the East and the West and the Roof? How much energy saving has been effected?
- 9.7. Do the structures use energy-efficient space conditioning, lighting and mechanical systems? Provide technical details. Provide details of the transformers and motor efficiencies, lighting intensity and air-conditioning load assumptions? Are you using CFC and HCFC free chillers? Provide specifications.
- 9.8. What are the likely effects of the building activity in altering the micro-climates? Provide a self assessment on the likely impacts of the proposed construction on creation of heat island & inversion effects?
- 9.9. What are the thermal characteristics of the building envelope? (a) roof; (b) external walls; and (c) fenestration? Give details of the material used and the U-values or the R values of the individual components.

- 9.10. What precautions & safety measures are proposed against fire hazards? Furnish details of emergency plans.
- 9.11. If you are using glass as wall material provides details and specifications including emissivity and thermal characteristics.
- 9.12. What is the rate of air infiltration into the building? Provide details of how you are mitigating the effects of infiltration.
- 9.13. To what extent the non-conventional energy technologies are utilised in the overall energy consumption? Provide details of the renewable energy technologies used.

#### 10. Environment Management Plan

The Environment Management Plan would consist of all mitigation measures for each item wise activity to be undertaken during the construction, operation and the entire life cycle to minimize adverse environmental impacts as a result of the activities of the project. It would also delineate the environmental monitoring plan for compliance of various environmental regulations. It will state the steps to be taken in case of emergency such as accidents at the site including fire.

## Annexure III Indicative list of submittals as required to fill in form I A

- Orientation of all maps should be with north pointing towards the top of the page.
- Maps showing topography should not merely have spot levels but should have contours.
- The scale of the map should be neither too small nor too large to interfere with comprehension of the project.
- The maps, tables and graphics should not be reduced in scale to an extent that the text becomes illegible.
- The units used should be the Standard International (SI) units on the metric system.
- The source of information must be indicated both in the text of project report and in the supporting documents such as drawings, maps, graphics and tables.

	<b>Topic</b>	<b>Submittals</b>	<b>Form IA</b>
1.	Land Environment	<ul style="list-style-type: none"> <li>▪ Conformity of proposed land use with the Development/Master Plan</li> <li>▪ If there is no approved Plan, availability of consent from appropriate authority</li> <li>▪ If the area is outside municipal limits /outside planning area, full justification for the proposed development and confirmation of the norms of UDPFI guidelines.</li> <li>▪ Surrounding features of the proposed site (within 500 meters)</li> <li>▪ Photographs showing the surrounding areas.</li> <li>▪ Site plan with contours and levels</li> <li>▪ Aerial image of site and immediate surroundings within 500 m.</li> </ul>	1.1
		<ul style="list-style-type: none"> <li>▪ Documents showing the following                             <ul style="list-style-type: none"> <li>▪ Total site area</li> <li>▪ Total built up area(provide area details)</li> <li>▪ Water consumption</li> <li>▪ Source of water supply</li> <li>▪ Quality tests of water</li> <li>▪ Sewage system of the site</li> <li>▪ Power requirement</li> <li>▪ Source of Power</li> <li>▪ Back up systems, if any</li> <li>▪ Connectivity to the city center, utilities and transportation networks</li> </ul> </li> </ul>	1.2

	Topic	Submittals	Form IA
		<ul style="list-style-type: none"> <li>▪ Community facilities</li> <li>▪ Air quality and ambient noise levels</li> <li>▪ Parking needs</li> </ul>	
		<ul style="list-style-type: none"> <li>▪ Provide details of impacts on existing facilities adjacent to existing site eg. Storm water drainage, traffic, noise and air quality, ecology, open spaces, utilities etc. The answers should be suitably annexed with photographs, impact analysis and projections as required.</li> </ul>	1.3
		<ul style="list-style-type: none"> <li>▪ Provide details of soil type, slope analysis, vulnerability to subsidence, seismicity.</li> <li>▪ Provide details of mitigation options adopted to reduce impacts of proposed construction with respect to above factors.</li> <li>▪ Provide details of erosion control plan.</li> </ul>	1.4
		<ul style="list-style-type: none"> <li>▪ Provide details of existing drainage plan, calculations of pre and post-construction run-off and detailed storm-water management plan with necessary drainage details.</li> </ul>	1.5
		<ul style="list-style-type: none"> <li>▪ Details of quantities of earthwork involved, transport of fill materials from outside the site.</li> <li>▪ Provide soil quality test of top soil. If top soil is proposed to be preserved, provide details of quantity of top soil stored, demarcated area on plan where top soil shall be stored and preservation plan.</li> </ul>	1.6
		<ul style="list-style-type: none"> <li>▪ Water supply source during construction. Certificate from the local authority like Jal Board etc to confirm availability of water, indicate the groundwater level, yield of the tube well.</li> <li>▪ Quality test report to prove water is suitable for construction activity.</li> <li>▪ Narrative on waste handling mechanism installed on site for storage and transportation schedule to managed landfills and recyclers depending upon the type of waste.</li> </ul>	1.7
		<ul style="list-style-type: none"> <li>▪ Provide details of how low lying and wetlands are getting modified from the proposed activity.</li> </ul>	1.8
		<ul style="list-style-type: none"> <li>▪ Give quantities of various types of wastes generated during construction including the construction labour and the means of disposal.</li> </ul>	1.9
2	Water Environment	<ul style="list-style-type: none"> <li>▪ Document indicating the water demand of the building, landscape, construction and process water use through water balance chart; source of water supplies (Groundwater, municipal, tanker etc.) and the break up of the supply for each source</li> </ul>	2.1
		<ul style="list-style-type: none"> <li>▪ Details of the proposed development around the site; Certificate from the local authority (Jal Board) indicating the groundwater level, yield of the tubewell; Certificate from the municipality indicating the capacity of the source of water supply for the region specifying the demand it will cater to.</li> </ul>	2.2, 2.5

	Topic	Submittals	Form IA
		<ul style="list-style-type: none"> <li>▪ Impact on other users if any</li> </ul>	
		<ul style="list-style-type: none"> <li>▪ Water quality certificate for each source from accredited lab</li> </ul>	2.3
		<ul style="list-style-type: none"> <li>▪ Calculation indicating the amount of wastewater generated</li> <li>▪ details of disposal of waste water</li> <li>▪ Treatment plant capacity and details of the treatment system</li> <li>▪ Details and drawings of the dual plumbing system for separation of grey and black water or for recycling of treated water or other source of water</li> <li>▪ Wastewater characteristics and Projected treated water quality</li> <li>▪ Details of the supply and storage system for reuse of the treated water</li> <li>▪ Water balance indicating the various points and quantity of treated water application</li> </ul>	2.4, 2.6, 2.13, 2.14
		<ul style="list-style-type: none"> <li>▪ Quantity of wastewater generated during construction</li> <li>▪ Characteristics of the waste stream including total suspended materials and list of chemicals from the construction site</li> <li>▪ Proposed treatment system along with the technical specifications and the capacity , storage plans for hazardous waste, if any.</li> </ul>	2.10, 2.12
		<ul style="list-style-type: none"> <li>▪ Site plan with contours showing location of <ul style="list-style-type: none"> <li>▪ Low lying areas</li> <li>▪ Trees to be retained</li> <li>▪ Building plans with extent of foundations</li> <li>▪ Rainwater harvesting structures planned</li> </ul> </li> <li>▪ Hydrogeology information and map in case of ground water recharge structure showing the following <ul style="list-style-type: none"> <li>▪ Soil characteristics. Certificate showing soil analysis, soil structure indicating infiltration rate</li> <li>▪ Aquifer profile including Groundwater potential of different hydro-geological units and the level of ground water development; Chemical quality of water in different aquifers</li> </ul> </li> <li>▪ Total run-off from the site (reconstruction) and Total rainwater harvesting potential of the scheme from various land uses and catchments in the planned development including projected water quality concerns from various catchments. Also attach the rainfall data used.</li> </ul>	2.7,2.8,2.9, 2.11

	Topic	Submittals	Form IA
		<ul style="list-style-type: none"> <li>▪ Total rainwater planned to be harvested as a percentage of the total demand</li> <li>▪ Detail design of rainwater harvesting structures</li> <li>▪ Proposed water quality remedial measures including details of filters to be used.</li> </ul> <p>Approval certificates from</p> <ul style="list-style-type: none"> <li>▪ Central/ State ground water board in case of ground water recharge structure</li> <li>▪ Civil engineers/ Architect if storage tanks are being planned</li> </ul> <ul style="list-style-type: none"> <li>▪ Plan indicating supply and delivery system from the storage facilities created and in case of ground water recharge structures, plan demonstrating adequacy of recharge structures during peak runoff. (Data of existing borewells should also be collected to determine the intake capacity of the recharge wells)</li> <li>▪ Post implementation Operations, maintenance &amp; monitoring plan proposed. Eg: AMC offered in contractual document; instruction and user manual; signages planned.</li> </ul>	
3	Vegetation	<p>Site plan along with a narrative showing existing vegetation, existing buildings, proposed buildings, existing slopes and existing site drainage pattern, staging and spill prevention measures, erosion and sedimentation control measures.</p> <p>Tree survey plan in the table 1 indicating protected / preserved / transplanted / removed trees.</p> <ul style="list-style-type: none"> <li>▪ Provide proposed landscape plan with identification of trees (different colour coding for trees to be used for protected, preserved, transplanted, removed trees) corresponding to the existing and new buildings and existing tree survey table. Explain in brief measures adopted for protecting existing landscape.</li> <li>▪ Site plan along with a narrative to demarcate areas on site from which top soil has to be gathered, designate area where it will be store, measures adopted for top soil preservation and indicate areas where it would be reapplied after construction is complete.</li> <li>▪ Indicate the time of construction with respect to rains.</li> <li>▪ Proposed landscape plan, clearly highlighting the trees removed (indicating the number of trees), if applicable, List details about species, which existed, and the species that have been replanted on site.</li> <li>▪ Give details of proposal for tree plantation, landscaping, creation of water bodies etc along with a layout plan to an appropriate scale.</li> </ul>	3.1, 3.2,3.3
4		<ul style="list-style-type: none"> <li>▪ A narrative over displacement of fauna- both terrestrial and aquatic or creation of barriers for their movement. Provide the details.</li> </ul>	4.1



	Topic	Submittals	Form IA
		<ul style="list-style-type: none"> <li>▪ A narrative on direct or indirect impacts on the avifauna of the area.</li> </ul>	4.2
		<ul style="list-style-type: none"> <li>▪ A narrative describing mitigation options to overcome the adverse impacts on fauna</li> </ul>	4.3
5	Air environment	<ul style="list-style-type: none"> <li>▪ A document showing the following <ul style="list-style-type: none"> <li>▪ The air quality parameters and pollution levels as analyzed as per IS-5182.</li> <li>▪ Mitigation measures adopted to reduce air pollution, dust generation due to construction activity.</li> </ul> </li> <li>▪ Predicted values of air quality due to increased traffic (use dispersion model)</li> <li>▪ Provide mitigation options to reduce heat islands</li> <li>▪ Predict impacts of dust , fumes, smoke, hazardous gases on all meteorological parameters.</li> </ul>	5.1, 5.2
		<ul style="list-style-type: none"> <li>▪ Road sections showing facilities for pedestrians and bicyclists.</li> <li>▪ Layout plan showing the entry and exit points, parking and circulation plan of vehicles.</li> <li>▪ Architectural site plan showing all the buildings and surrounding roads and open spaces, confirming the guidelines given in section 3.2.2.2, geometric design improvement and road safety.</li> <li>▪ Provide detailed parking place and provide detailed parking estimate vis-à-vis NBC norms and local bye-laws.(Cars, Two-wheelers, buses etc)</li> </ul>	5.3
		<ul style="list-style-type: none"> <li>▪ Site plan showing buildings, roads and open spaces, confirming the hierarchy of roads as per the rules given by UDPFI guidelines</li> </ul>	5.4
		<ul style="list-style-type: none"> <li>▪ Site plan for construction management showing the layout of noise and dust barriers</li> <li>▪ Proof of PUC check of vehicles and machinery between every 3 months period of construction work</li> <li>▪ Give post construction estimate of increase in noise and mitigation options.</li> </ul>	5.5
		<ul style="list-style-type: none"> <li>▪ Drawings and specification of DG room and DG sets with acoustic enclosure and stack height details.</li> </ul>	5.6
6	Aesthetics	<ul style="list-style-type: none"> <li>▪ Site location along with panoramic view of the project site and vicinity.</li> <li>▪ Surrounding features of the proposed site (within 500 meters).</li> <li>▪ Buildings sited near potential views, monumental, natural, city views, narrative and details of design considerations incorporated in building design to preserve the views should be provided.</li> <li>▪ Provide a detailed narrative with photos addressing the queries in 6.1 to 6.4.</li> </ul>	6.1,6.2,6.3, 6.4

	<b>Topic</b>	<b>Submittals</b>	<b>Form IA</b>
7	Socio-economic Aspects	<ul style="list-style-type: none"> <li>▪ The density and projected demographic profile of the proposed development</li> <li>▪ A narrative over the detail of the existing social infrastructure around the proposed project.</li> <li>▪ Give details as requested for in questions 7.1 to 7.3.</li> <li>▪ Details of recycled materials used in roads and structures</li> </ul>	7.1, 7.2
8	Building Materials	<ul style="list-style-type: none"> <li>▪ Site plan showing construction management plan presenting the material storage spaces, layout of machinery and waste disposal</li> </ul>	8.2
		<ul style="list-style-type: none"> <li>▪ Specifications of materials used in each component part of the building and landscape (envelope, superstructure, openings and roads and surrounding landscape), Plans and sections of buildings showing effective methods of construction, Justification of the water saving methods in construction techniques,</li> <li>▪ Details of the new technologies or non-conventional materials used</li> </ul>	8.3
		<ul style="list-style-type: none"> <li>▪ Application for planning permission accompanied by site waste management plan, including identification of volume and type of structures to be demolished and excavations, reuse and recovery of the materials</li> </ul>	8.4
		<ul style="list-style-type: none"> <li>▪ Review and detailed survey and documentation of waste generated at the demolition site and quantities of the elements to be taken out and preserved before demolition, e.g. door and window frames, glass pans, wooden panels, grills, floor tiles trees, steel members and other recyclables.</li> </ul>	8.4
9	Energy Conservation	<ul style="list-style-type: none"> <li>▪ A document showing the following Details of total power requirements in KVA <ul style="list-style-type: none"> <li>▪ Source of supply</li> <li>▪ Back up source and capacity</li> <li>▪ Back up sizing</li> <li>▪ Fuel consumption by the back up source</li> <li>▪ Energy consumption per sqm using the BEPI method as elaborated in section 6.5</li> <li>▪ Narrative on energy conservation techniques (solar passive, building materials, systems, renewable energy sources)</li> </ul> </li> </ul>	9.1, 9.2
		<ul style="list-style-type: none"> <li>▪ Fenestration schedule and provide details in conformance to ECBC recommendations as highlighted in Table 4.1.3</li> <li>▪ U factor and SHGC of glass. Indicate if overhangs or side fins are used for compliance purposes. If so, provide projection factor calculations</li> </ul>	9.3
		<ul style="list-style-type: none"> <li>▪ One drawing showing the following</li> </ul>	9.4

	<b>Topic</b>	<b>Submittals</b>	<b>Form IA</b>
		<ul style="list-style-type: none"> <li>▪ Site plan with north line.</li> <li>▪ Building plan with internal layouts showing all functional spaces.</li> <li>▪ Building section and detailed typical wall sections indicating the material and thickness of each material.</li> <li>▪ Narrative on solar passive architectural techniques used</li> <li>▪ Provide Bill of Quantities indicating the selected building materials.</li> </ul>	
		<ul style="list-style-type: none"> <li>▪ Provide details of renewable energy systems including system sizing and design energy delivered , building costs and integration details.</li> </ul>	9.5,9.13
		<ul style="list-style-type: none"> <li>▪ Cut sheet for each window and shading size clearly dimensioned. Along with each window cut sheet, the orientation should be marked.</li> <li>▪ Provide window details in the format given in Table 2</li> <li>▪ Provide details of shading on East, West walls and roof.</li> </ul>	9.6
		<ul style="list-style-type: none"> <li>▪ Narrative demonstrating the measures incorporated to mitigate negative impacts on the microclimate of the site due to building activity.</li> </ul>	9.8
		<ul style="list-style-type: none"> <li>▪ Compliance document demonstrating conformance to prescriptive requirement of energy conservation building code or building envelope tradeoff options</li> </ul>	9.9, 9.7, 9.11



## Annexure for submittals

### 6.8.7 Building Energy Performance Index (BEPI)

Building energy performance index is the ratio of annual energy consumed in a building to the total built-up area and provides comparisons across same building type of different sizes or different types of buildings.

Table 6.30: Recommended BEPI for different types of buildings

S No.	Bldg. classifications	Occupancy (Sq ft/ person)	Building Energy performance index (kWh/m <sup>2</sup> )	
			Warm & humid	Composite/Hot & dry
1	Apartment, High Rise	175	100	90
2	Auditoriums, Theatres	11	300	150
3	Educational Facilities	25	200	175
4	Hospitals	80	500	400
5	Hotels	150	300	250
6	Libraries & Museums	60	150	125
7	Offices	110	150	125
8	Malls	75	250	200

\* The above BEPI includes energy consumption in lighting & air conditioning systems

### 6.8.8 BEPI calculation method

Table 6.31: Estimation of energy consumption in lighting system

S No.	Building type	Total indoor lighting load (Kilo watt)	Operating hours/Day	Diversity Factor for lighting load operation	Energy consumption in lighting system (kWh)
		Col C	Col D	Col E	Col F (Col C*Col D*Col E)
1	Apartment, High Rise		10	0.6	
2	Auditoriums, Theatres		10	0.7	
3	Educational Facilities		10	0.6	

---

		Total indoor lighting load (Kilo watt)	Operating hours/Day	Diversity Factor for lighting load operation	Energy consumption in lighting system (kWh)
4	Hospitals		12	0.7	
5	Hotels		12	0.8	
	Libraries &				
6	Museums		10	0.8	
7	Offices		10	0.7	
8	Malls		10	0.9	

---

Table 6.32 : Estimation of energy consumption in air conditioning system

S No.	Building type	Total cooling load (TR) Col C	Total connected load of chiller plants (Kilo watt) Col D	Total connected load of Chilled water pumps (kilo watt) Col E	Total connected load of condenser water pumps (kilo watt) Col F	Total connected load of cooling tower fans (kilo watt) Col G	Total system load (Kilo watt) Col H (Col D+Col E+Col F+Col G)	Chiller efficiency (IKW/TR) Col I ( Col D/ Col C)	System efficiency (IKW/TR) Col J (Col H/ Col C)	Total connected load of AHUs fans (kilo watt) Col K	Total connected load of FCUs fans (kilo watt) Col L	Operating hours/Day Col M	Diversity Factor for AC load operation Col N	Energy consumption in AC system (kWh) Col O {(Col H+ColK+ ColL)*Col M*Col N*275
1	Apartment, High Rise Auditoriums,											10	0.6	
2	Theatres											10	0.7	
3	Education al Facilities											10	0.7	
4	Hospitals											24	0.7	
5	Hotels											24	0.7	
6	Libraries & Museums											10	0.6	
7	Offices											10	0.7	
8	Malls											10	0.9	

Table 6.33 : Estimation of building energy performance index

S No.	Building type	Energy consumption in lighting system (kWh) Col C	Energy consumption in AC system (kWh) Col D	Total energy consumption (kWh) Col E (Col C+Col D)	Built-up Area (m <sup>2</sup> ) Col F	Energy Performance Index (kWh/m <sup>2</sup> ) Col G (Col E/Col F)
1	Apartment, High Rise					
2	Auditorium, Theatres					
3	Educationa					
4	l Facilities					
5	Hospitals					
6	Hotels					
7	Libraries & Museums					
8	Offices					
	Malls					